

CAEN 2016 / 2017 Product Catalog



Electronic Instrumentation



A masterpiece from Siena, or a detector? You decide...

2016 / 2017 Product Catalog



We are proud of the high quality of our products.

ISO 9001

ISO 9001:2008 approved quality system ensures all our internal processes.

From R&D to the registration of the incoming purchase orders, through:

- Resource Planning
- Scheduling
- Production

Our quality system is responsible for the proper functioning of all our internal processes and is subject to regularly unannounced audits, carried out by the National Standards Authority.

From the initial product design and its development stages, till the delivery of the production batches, we follow documented procedures that cover every aspect of our business. The auditing of our procedures by an independent third party guarantees that our business runs smoothly and efficiently.

The quality of CAEN S.p.A. products is constantly monitored by the application of the UNI EN ISO 9001:2008 standard. CAEN S.p.A. is ISO 9001 certified since 1998.

ISO9001:2008
 certified Company



ISO 9001:2008
 cert. n. 9105.CAEN

Authorised
 research laboratory
 of the MIUR



CAEN New Management Team

Dear Friends,

it has been 36 years since CAEN started its business and we believe we provided a great support to the international scientific community around the world thanks to a strong cooperation with all the researchers.

Time goes by very quickly and as founders of CAEN we believe it is the right time to pass the daily operations of CAEN to the new and well prepared generations, but still maintaining our personal involvement.

As always we are looking far away, facing new challenges and allowing CAEN to keep innovating and growing.

We will always be at your side, ready to support you all around the world.

With infinite gratitude,



M. Givoletti

Marcello Givoletti



Piero Salvadori

Piero Salvadori



Luigi Pardini

Luigi Pardini

CAEN Management



Jacopo Givoletti

President

j.givoletti@caen.it



Franco Vivaldi

Vice President

f.vivaldi@caen.it



Michela Givoletti

Chief Financial Officer

michela.givoletti@caen.it



Giorgio Salvadori

Chief Supply Chain Director

g.salvadori@caen.it



Claudio Raffo

Chief Operating Officer

c.raffo@caen.it



Nicola Paoli

Marketing and Sales Director

nicola@caentech.com



Carlo Tintori

Chief Technical Officer

c.tintori@caen.it



Gianni Di Maio

Maintenance Manager

g.dimaio@caen.it



Maurizio Lippi

Communication Office Manager

m.lippi@caen.it



Claudio Landi

Power Supply Division Manager

c.landi@caen.it



Alberto Lucchesi

Software Division Manager

a.lucchesi@caen.it



Michele Zardetto

Safety & Quality Assurance Manager

m.zardetto@caen.it



CAEN Network Contacts

Electronic Instrumentation



Sandra Picchi
Marketing Assistant
s.picchi@caen.it

Electronic Instrumentation

REST OF THE WORLD



Ines Llorente
Marketing Assistant
i.llorente@caen.it

Electronic Instrumentation

REST OF THE WORLD



Carolina Stefani
Marketing Assistant
c.stefani@caen.it

CAEN S.p.A.

Via Vetraia 11

55049 - Viareggio • Italy

Phone +39.0584.388.398

Fax +39.0584.388.959

info@caen.it

www.caen.it



CAEN GmbH

Klingenstraße 108

D-42651 Solingen • Germany

Phone +49 (0)212.254.4077

Fax +49 (0)212.25.44079

Mobile +49 (0)151.16.548.484

info@caen-de.com

www.caen-de.com



Arp Nico von Düring

Geschäftsführer

n.vonduering@caen-de.com



CAEN Technologies, Inc.

1140 Bay Street - Suite 2C

Staten Island, NY 10305 • USA

Phone +1.718.981.0401

Fax +1.718.556.9185

info@caentechnologies.com

www.caentechnologies.com



Marco Locatelli

Field Application & Sales Manager

m.locatelli@caen.it



CAEN Service Team



Gianni Di Maio
Maintenance Manager
g.dimaio@caen.it



Andrea Testa
Test Manager
a.testa@caen.it



Enrico Pardini
Group Leader
e.pardini@caen.it



Alessandro Cortopassi
Group Leader
a.cortopassi@caen.it

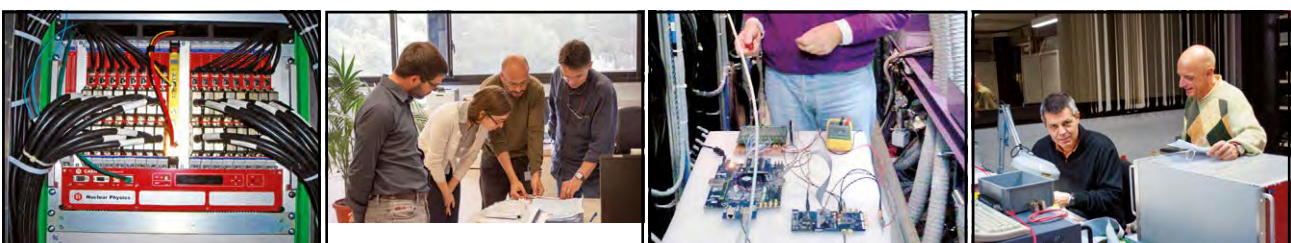
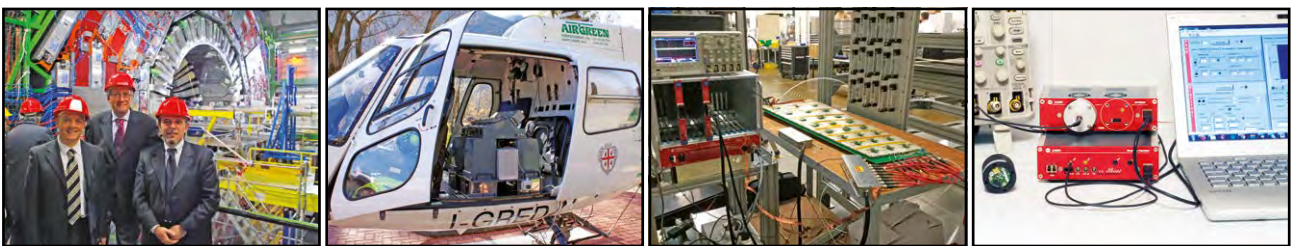
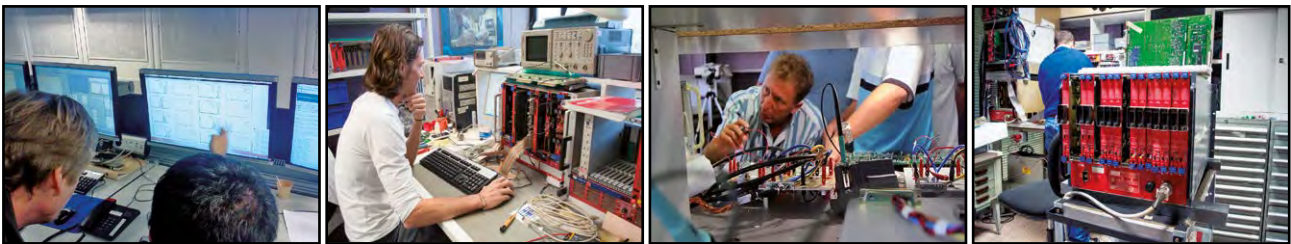
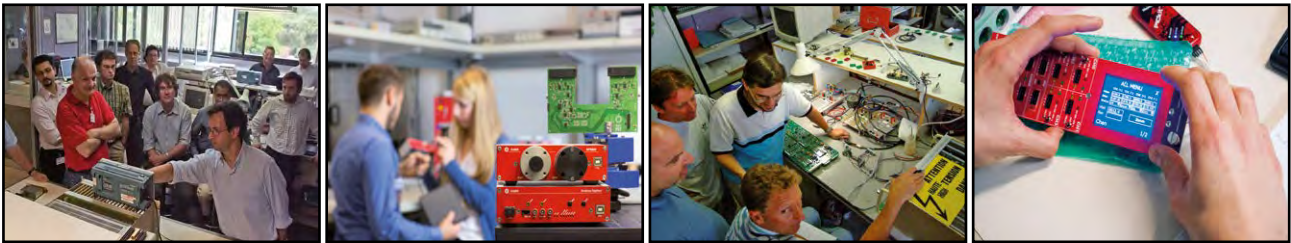

Table of Contents

This Catalog represents the state-of-the-art of CAEN's products offering at the date of printing. To check the updated list of all our products, please visit our web site (www.caen.it). Nevertheless, the products appearing either on the Catalog or on our web site do not represent all our expertise, as almost 20% of CAEN production is custom designed.

If you don't find the Product you need in our Catalog, or if you are starting a new experiment and require a completely new design, feel free to contact us. CAEN will help you at any stage of your project.

Legend

pag **XVI**

CAEN Company Profile

pag **XVIII**

	ST	pag
Power Supplies		1
Power Supplies / Introduction to High Voltage Power Supplies		2
Power Supplies / Universal Multichannel Systems		15
Power Supplies / Universal Multichannel Systems / Mainframes		16
SY5527	Universal Multichannel Power Supply System / 19"wide, 4U-high (6 slot)	16
SY4527	Universal Multichannel Power Supply System / 19"wide, 8U-high (16 slot)	16
SY5527LC	Universal Multichannel Power Supply System Low Cost / 19"wide, 4U-high (4 slot)	20
SY4527LC	Universal Multichannel Power Supply System Low Cost / 19"wide, 8U-high (10 slot)	20
Power Supplies / Universal Multichannel Systems / Mainframes / CPU Modules and Power Supply Units		21
A4528x	SY4527/SY5527 CPU Modules	21
A4531	SY4527/SY5527 Primary Power Supply 600 W	21
A4532	SY4527/SY5527 Optional Single Power Supply Unit 600 W	21
A4533	SY4527/SY5527 Optional Single Power Supply Unit 1200 W	21
Power Supplies / Universal Multichannel Systems / Mainframes / High Voltage and Low Voltage Multichannel Boards		22
Power Supplies / Universal Multichannel Systems / Multichannel Boards / How to find your Power Supply		26
Power Supplies / Universal Multichannel Systems / Multichannel Boards / Low Voltage Boards Family / A151xB - A251x		27
A1513B	6 Channel 10 V/2.7 A Individual Floating Channel Board	27
A1516B	6 Channel 15 V/1.5 A Individual Floating Channel Board	27
A1517B	6 Channel 7 V/4 A Individual Floating Channel Board	27
A1518B	6 Channel 4.5 V/6 A Individual Floating Channel Board	27
A2517	8 Channel 5 V/15 A (50 W) Individual Floating Channel Board	27
A2518	8 Channel 8 V/10 A (50 W) Individual Floating Channel Boards	27
A2519	8 Channel 15V/5 A (50 W) Individual Floating Channel Boards	27
Power Supplies / Universal Multichannel Systems / Multichannel Boards / up to 500 V High Voltage Family / A1539 - A154x - A704x - A151x		28
A1539	12/24/32 Channel 100 V/15 mA Common Floating Return Boards	NEW 28
A1540	12/24/32 Channel 100 V/1 mA Common Floating Return Boards	NEW 28
A1540H	12/24/32 Channel 100 V, 15 mA/20 μ A Common Floating Return Dual Range Boards	NEW 28
A1541	12/24/32 Channel 500 V/10 mA Common Floating Return Boards	NEW 28
A1542	12/24/32 Channel 500 V/1 mA Common Floating Return Boards	NEW 28
A1542H	12/24/32 Channel 500 V, 10 mA/20 μ A Common Floating Return Dual Range Boards	NEW 28
AG539	12/24/32 Channel 100 V/15 mA Common Ground Boards	NEW 28
AG540	12/24/32 Channel 100 V/1 mA Common Ground Boards	NEW 28
AG541	12/24/32 Channel 500 V/10 mA Common Ground Boards	NEW 28
AG542	12/24/32 Channel 500 V/1 mA Common Ground Boards	NEW 28
Power Supplies / Universal Multichannel Systems / Multichannel Boards / Solution for High Density Detectors / A7040 - AG7040 - A7042 - AG7042		31
A7040	12/24/36/48 Channel 100 V/500 μ A Common Floating Return Boards	CS 31
A7042	12/24/36/48 Channel 500 V/500 μ A Common Floating Return Boards	NEW 31
AG7040	12/24/36/48 Channel 100 V/500 μ A Common Ground Boards	CS 31
AG7042	12/24/36/48 Channel 500 V/500 μ A Common Ground Boards	NEW 31
Power Supplies / Universal Multichannel Systems / Multichannel Boards / Solution for Silicon Detectors and APDs / A151x - A1520P		32
A1510	12 Channel 100 V, 1/10 mA Individual Floating Channel Dual Range Board	32
A1511B	12 Channel 500 V, 1/10 mA Individual Floating Channel Dual Range Board	32
A1512	12 Channel 500 V, 1 mA/100 μ A Individual Floating Channel Dual Range Board	32

A1519B	12 Channel 250 V, 0.1/1 mA Individual Floating Channel Dual Range Board		32
A1520P	12 Channel 500 V/15 mA Individual Floating Channel Board		32
Power Supplies / Universal Multichannel Systems / Multichannel Boards / up to 4kV High Voltage Family / A15xx - A18xx - AP932 - A7xxx			33
A1535	12/24 Channel 3.5 kV/3 mA (9 W) Common Floating Return Boards		33
A1536	12/24/32 Channel 3 kV/1 mA Common Floating Return Boards		33
A1538D	12 Channel 1.5 kV/10 mA (12W) Common Floating Return Board		33
A1821	12 Channel 3 kV, 200/20 μ A Common Ground Dual Range Board		33
A1821H	12 Channel 3 kV, 200/10 μ A Common Ground Dual Range Board		33
A1833	12 Channel 3 kV/3mA, 4 kV/2 mA, 4 kV/0.2 mA Common Ground Dual Range Board		33
AG535	12/24 Channel 3.5 kV/3 mA (6 W) Common Ground Boards		33
AG536	12/24/32 Channel 3 kV/1 mA Common Ground Boards		33
AG538D	12 Channel 1.5 kV/10 mA (12W) Common Ground Board		33
AP932	1 Channel 3 kV/30mA Individual Floating Board (SHV conn)		33
Power Supplies / Universal Multichannel Systems / Multichannel Boards / General Purpose High Density Family / A7030 - AG7030			36
A7030	12/24/36/48 Channel 3 kV/1 mA (1.5W) Common Floating Return Boards	NEW	36
AG7030	12/24/36/48 Channel 3 kV/1 mA (1.5W) Common Ground Boards	NEW	36
Power Supplies / Universal Multichannel Systems / Multichannel Boards / Solution For Gas Electron Multiplier Detectors / A1515 - A15151TG - A1515QG			37
A1515	16 Channel Floating 1kV, 1/0.1 mA Board	NEW	37
A1515TG	14 Channel Floating 1kV, 1/0.1 mA Board for Triple GEM detectors	NEW	37
A1515QG	16 Channel Floating 1kV, 1/0.1 mA Board for Quadruple GEM detectors	NEW	37
Power Supplies / Universal Multichannel Systems / Multichannel Boards / General Purpose High Power & High Resolution Power Supplies / A(G)7236 - A(G)7435			38
A7236	32 Channel 3.5 kV/1.5 mA (4W) Common Floating Return Board	NEW	38
A7435	24 Channel 3.5 kV/3.5 mA (9W) Common Floating Return Board	NEW	38
AG7236	32 Channel 3.5 kV/1.5 mA (4W) Common Ground Board	NEW	38
AG7435	24 Channel 3.5 kV/3.5 mA (9W) Common Ground Board	NEW	38
Power Supplies / Universal Multichannel Systems / Multichannel Boards / up to 8 kV High Voltage Family / A1550 - A15xxH - A1534			39
A1534	12 Channel 8 kV/200 μ A Individual Floating Channel Board		39
A1550	12/24/32 5 kV/1 mA Common Floating Return Boards		39
A1561H	12 Channel 6 kV/20 μ A Common Floating Return Board		39
AG550	12/24/32 Channel 5 kV/1 mA Common Ground Boards		39
Power Supplies / Universal Multichannel Systems / Multichannel Boards / High Precision Solution for Germanium Detectors / A1560H - A1580H			41
A1560H	8/16 Channel 6 kV/20 μ A Common Floating Return Boards	NEW	41
A1580H	8/16 Channel 8 kV/20 μ A Common Floating Return Boards	NEW	41
Power Supplies / Universal Multichannel Systems / Multichannel Boards / up to 15 kV High Voltage Family / A152x - A1590			42
A1523	6 Channel 12 kV/1 mA Common Floating Return Board		42
A1524	6 Channel 12 kV/100 μ A Common Floating Return Board		42
A1590	16 Channel 9 kV/100 μ A Common Floating Return Board	NEW	42
AG523	6 Channel 12 kV/1 mA Common Ground Board		42
AG524	6 Channel 12 kV/100 μ A Common Ground Board		42
AG590	16 Channel 9 kV/100 μ A Common Ground Board	NEW	42
Power Supplies / Universal Multichannel Systems / Multichannel Boards / Solution for Resistive Plate Chamber Detectors / A1526			44
A1526	6 Channel 15 kV, 1/0.1 mA Common Floating Return Board		44
Power Supplies / Universal Multichannel Systems / Multichannel Boards / Bipolar High Voltage Family / A1588			45
A1588	8 Channel \pm 2 kV/500 μ A 4 Quadrant Bipolar Board		45
Power Supplies / Universal Multichannel Systems / Multichannel Boards / HV Adapters (DB37 and Radial to SHV cable) / A1015x - A64x - R64x			46
A1015	16 Floating Channel Multipin Radial to SHV connector Adapter for A1515 board (Max: 5 kV - Desktop)		46
A1015GM	14/16 Stacked Channel Multipin Radial to SHV connector Adapter for A1515TG/A1515QG board (Max: 5 kV - Desktop)		46
A1015VM	Analog Voltage Monitor for A1515/A1515TG/A1515QG board		46
A646	12 Channel DB37 to SHV connector Adapter (Max: 500V - Desktop)		46
A647	24 Channel Multipin Radial to SHV connector Adapter (Max: 8kV - Desktop)		46
A648	48 Channel Multipin Radial to SHV connector Adapter (Max: 3kV - Desktop)		46
A649	32 Channel Multipin Radial to SHV connector Adapter (Max: 3kV - Desktop)		46
A649B	32 Channel Multipin to SHV connector Adapter (Max: 8 kV - Desktop)		46
R647	24 Channel Multipin Radial to SHV connector Adapter (Max: 8kV - 19" Rack)		46
R648	48 Channel Radial to SHV connector Adapter (Max: 3kV - 19" Rack)		46
R649	32 Channel Radial to SHV connector Adapter (Max: 3kV - 19" Rack)		46
R649B	32 Channel Radial to SHV connector Adapter (Max: 8kV - 19" Rack)		46

Power Supplies / VME-NIM Power Supplies**47**

V6519	6 Channel 500 V/3 mA VME HV Power Supply Module		48
V6521	6 Channel 6 kV/300 μ A VME HV Power Supply Module		48
V6521H	6 Channel 6 kV/20 μ A VME HV Power Supply Module		48
V6533	6 Channel 4 kV/3 mA VME HV Power Supply Module (9 W)		48
V6534	6 Channel 6 kV/1 mA VME HV Power Supply Module		48
Power Supplies / VME-NIM Power Supplies / NIM High Voltage Power Supplies / NDT14xx - N14xxET - N14xx			50
N1419/A/B	4/2/1 Ch Reversible 500 V/200 μ A NIM HV Power Supply Module (USB)		50
N1419ET	4 Ch Reversible 500 V/200 μ A NIM HV Power Supply Module (USB/Ethernet/Tscreen)		50
N1470/A/B	4/2/1 Ch Reversible 8 kV/3 mA (8 W) NIM HV Power Supply Module (USB)		50
N1470AL	2 Ch Reversible 8 kV/3 mA (8 W) NIM HV Power Supply Module Low Cost Locally Programmable		50
N1470AR	2 Ch Reversible 8 kV/3 mA (8 W) NIM HV Power Supply Module (USB) Low Cost Remotely Programmable		50
N1470ET	4 Ch Reversible 8 kV/3 mA (8 W) NIM HV Power Supply Module (USB/Ethernet/T screen)		50
N1471/A/B	4/2/1 Ch Reversible 5.5 kV/300 μ A NIM HV Power Supply Module (USB)		50
N1471ET	4 Ch Reversible 5.5 kV/300 μ A NIM HV Power Supply Module (USB/Ethernet/T screen)		50
N1471H/A/B	4/2/1 Ch Reversible 5.5 kV/20 μ A NIM HV Power Supply High Accuracy Module (USB)		50
N1471HET	4 Ch Reversible 5.5 kV/20 μ A NIM HV Power Supply High Accuracy Module (USB/Ethernet/T.screen)		50
NDT1419	4 Ch Reversible 500 V/200 μ A NIM/Desktop HV Power Supply Module (USB/Ethernet/T.screen)		50
NDT1470	4 Ch Reversible 8 kV/3 mA (8 W) NIM/Desktop HV Power Supply Module (USB/Ethernet/T.screen)		50
NDT1471	4 Ch Reversible 5.5 kV/300 μ A NIM/Desktop HV Power Supply Module (USB/Ethernet/T.screen)		50
NDT1471H	4 Ch Reversible 5.5 kV/20 μ A NIM/Desktop HV Power Supply High Accuracy Module (USB/Ethernet/T.screen)		50
Power Supplies / VME-NIM Power Supplies / NIM High Voltage Power Supplies / N472			52
N472	4 Channel 6 kV Power Supply		52
Power Supplies / VME-NIM Power Supplies / NIM High Voltage Power Supplies / N1570			53
N1570	2 Channel 15 kV/1 mA (10 W) NIM HV Power Supply Module (USB/Ethernet/T.screen)	NEW	53
Power Supplies / VME-NIM Power Supplies / NIM Low Voltage Power Supplies / N5424			54
N5424	Quad NIM Power distributor		54
Power Supplies / Standalone Power Supplies			55
Power Supplies / Standalone Power Supplies / Desktop High Voltage Power Supplies / DT55xxE			56
DT5519E	4 Channel 500 V/3 mA Desktop HV Power Supply Module (USB/Ethernet)	NEW	56
DT5521E	4 Channel 6 kV/300 μ A Desktop HV Power Supply Module (USB/Ethernet)	NEW	56
DT5521HE	4 Channel 6 kV/20 μ A Desktop HV Power Supply Module (USB/Ethernet)	NEW	56
DT5533E	4 Channel 4 kV/3 mA (4 W) Desktop HV Power Supply Module (USB/Ethernet)	NEW	56
DT5534E	4 Channel 6 kV/1 mA (4 W) Desktop HV Power Supply Module (USB/Ethernet)	NEW	56
Power Supplies / Standalone Power Supplies / Desktop High Voltage Power Supplies / DT14xxET			58
DT1419ET	4 Ch Reversible 500 V/200 μ A Desktop HV Power Supply Module (USB/Ethernet/T.screen)	NEW	58
DT1470ET	4 Ch Reversible 8 kV/3 mA (8 W) Desktop HV Power Supply Module (USB/Ethernet/T.screen)	NEW	58
DT1471ET	4 Ch Reversible 5.5 kV/300 μ A Desktop HV Power Supply Module (USB/Ethernet/T.screen)	NEW	58
DT1471HET	4 Ch Reversible 5.5 kV/20 μ A Desktop HV Power Supply High Accuracy Module (USB/Ethernet/T.screen)	NEW	58
Power Supplies / Standalone Power Supplies / Desktop High Voltage Power Supplies / DT547x			59
DT5470	1 Ch 5 kV/200 μ A USB-Powered Desktop HV Power Supply	NEW	59
DT5471	1 Ch 3 kV/500 μ A (1 W) USB-Powered Desktop HV Power Supply	NEW	59
DT5472	1 Ch 500 V/1 mA USB-Powered Desktop HV Power Supply	NEW	59
Power Supplies / Standalone Power Supplies / Desktop Low Voltage Power Supplies / DT5423			60
DT5423	Quad Desktop Power distributor		60
Power Supplies / Standalone Power Supplies / Rack High Voltage Power Supplies / R14xxET			61
R1419ET	8/4 Ch Reversible 500 V/200 μ A 19" HV Power Supply Module (USB/Ethernet/T.screen)	NEW	61
R1470ET	8/4 Ch Reversible 8 kV/3 mA (8 W) Desktop 19" Power Supply Module (USB/Ethernet/T.screen)	NEW	61
R1471ET	8/4 Ch Reversible 5.5 kV/300 μ A Desktop 19" Power Supply Module (USB/Ethernet/T.screen)	NEW	61
R1471HET	8/4 Ch Reversible 5.5 kV/20 μ A 19" HV Power Supply High Accuracy Module (USB/Ethernet/T.screen)	NEW	61
Power Supplies / Standalone Power Supplies / PCB High Voltage Power Supplies / A750x			62
A7501	1 Ch 2100 V/100 μ A High Efficiency HV Power Supply Module	NEW	62
A7504	1 Ch 4000 V/100 μ A High Efficiency HV Power Supply Module	NEW	62
A7505	1 Ch 1600 V/500 μ A High Efficiency HV Power Supply Module	NEW	62
A7508	1 Ch 800V/50 μ A High Efficiency HV Power Supply Module	NEW	62
Power Supplies / Standalone Power Supplies / PCB High Voltage Power Supplies / A7560			63
A7560	2 Ch Bipolar \pm 6kV/10 μ A High Performance HV Power Supply Module	NEW	63
Power Supplies / Standalone Power Supplies / PCB High Voltage Power Supplies / A7501PB			64
A7501PB	Single Channel High Reliability, High Voltage Power Supply Box	NEW	64

Power Supplies / EASY (Embedded Assembly SYstem)			65
A1676A	EASY3000 Branch Controller		66
A3000Fx	EASY3000 Fan Units		66
A30xx - A3602	EASY3000 LV Floating Power Supply Boards		66
A3100x	EASY3000 LV Floating Power Supply Boards		66
A348x	EASY3000 AC/DC Converters		66
A35xx	EASY3000 HV Power Supply Boards		66
A380x	128 Channel ADC/DAC/Temperature Sensor Boards		66
EASY3000x	EASY3000 Remote Crates		66
Power Supplies / High Power Low Voltage System			69
SY8800	Universal Multichannel Low Voltage Power Supply System		70
Power Supplies / Power Supply Control Software			71
GECO2020	General Control Software for CAEN HV Power Supplies		72
CAEN HV Wrapper	Library for CAEN Power Supply Control		73
HiVoCS	Web based Control Software for SY4527 and SY5527 Systems		74
Sy Smart Touch	Control Software for SY4527 and SY5527 Systems		75
LabVIEW Driver	Instrument Driver for Power Supply Modules		76
OPC Server	OPC Server for CAEN Power Supplies		77
EPICS IOC (PSM)	EPICS IOC for Power Supply Modules		78
EPICS IOC (SYx527/SY5527)	EPICS IOC for SY4527 and SY5527 Systems		78

ST pag

Modular Pulse Processing Electronics **79**

Modular Pulse Processing Electronics / Introduction to Modular Pulse Processing Electronics **80**

Modular Pulse Processing Electronics / Waveform Digitizers **83**

Modular Pulse Processing Electronics / Waveform Digitizers / Introduction to Waveform Digitizers **84**

Modular Pulse Processing Electronics / Waveform Digitizers / Digitizer Families **90**

720 Digitizer Family	8/4/2 Channel 12-bit 250 MS/s Digitizer		90
724 Digitizer Family	8/4/2 Channel 14-bit 100 MS/s Digitizer		92
725 Digitizer Family	16/8 Channel 14-bit 250 MS/s Digitizer	NEW	94
730 Digitizer Family	16/8 Channel 14-bit 500 MS/s Digitizer		96
740 Digitizer Family	64/32 Channel 12-bit 62.5 MS/s Digitizer		98
751 Digitizer Family	8-4/4-2 Channel 10-bit 1-2 GS/s Digitizer		100
761 Digitizer Family	2/1 Channel 10-bit 4 GS/s Digitizer		102
742 Digitizer Family	32+2/16+1 Channel 12-bit 5 GS/s Switched Capacitor Digitizer		104
743 Digitizer Family	16/8 Channel 12-bit 3.2 GS/s Switched Capacitor Digitizer		106

Modular Pulse Processing Electronics / Waveform Digitizers / Acquisition Modes **108**

Modular Pulse Processing Electronics / Waveform Digitizers / Waveform Recording **109**

CAENScope	CAEN Digitizer Signal Inspection and Waveform Recording Software		109
WaveDump	Open Source Acquisition Software for Developers		110
WaveCatcher	Advanced Software Tool for 743 Digitizers		111

Modular Pulse Processing Electronics / Waveform Digitizers / Digital Pulse Processing **112**

CoMPASS	Multiparametric DAQ Software for Physics Applications	NEW	112
MC ² Analyzer	User Friendly Software for Digital Pulse Height Analysis		113
DPP-PSD	Digital Charge Integration and Pulse Shape Analysis		114
DPP-QDC	Digital Charge to Digital Converter for 740 Digitizers	NEW	115
DPP-ZLEplus	Advanced Zero Length Encoding		116
DPP-DAW	Channel Independent Zero Suppression with Dynamic Acquisition Window	NEW	117

Modular Pulse Processing Electronics / Waveform Digitizers / Tools / Drivers, Libraries and Configuration Tools **118**

Modular Pulse Processing Electronics / Waveform Digitizers / Tools / Libraries **119**

CAENComm	Interface Library for CAEN Data Acquisition Modules		119
----------	---	--	-----

CAENDigitizer	Library of Functions for CAEN Digitizers High Level Management		119
CAENDPP	High Level Library for CAEN Boards Running DPP Firmware		119
Modular Pulse Processing Electronics / Waveform Digitizers / Tools / Configuration Tools			120
CAENUpgrader	Firmware Upgrade Tool for Front-end Boards Bridges & VME Power Supply		120
CAEN VME Demos	Demo Applications for CAEN Bridges Control		120
CAEN SyncTest	Demo Software for CAEN Digitizers Synchronization		120
Modular Pulse Processing Electronics / NIM			121
Modular Pulse Processing Electronics / NIM / ADCs (Peak Sensing) / Multichannel Analyzers			122
N957	8k Multichannel Analyzer		122
Modular Pulse Processing Electronics / NIM / Analog Pulse Processors			122
N914	8 Fold Photomultiplier Pulse Processor		122
Modular Pulse Processing Electronics / NIM / Amplifiers (Fast)			122
N978	4 Channel Variable Gain Fast Amplifier		122
N979	16 Channel Fast Amplifier		123
N979B	16 Channel Mixed Gain Fast Amplifier		123
Modular Pulse Processing Electronics / NIM / Amplifiers (Spectroscopy)			123
N968	Spectroscopy Amplifier		123
N1068	16 Ch Programmable Spectroscopy Amplifier with Time Filter, CFD and Pile-Up Rejection	NEW	124
N1168	16 Ch Fast Scintillator Programmable Signal Processor and 16 ch CFD	CS	125
N1568A	16 Ch Programmable Spectroscopy Amplifier & Dual 16 Ch CFD (30%; 80%)		126
N568E - N568ELC - N568EB	16 Channel Programmable Spectroscopy Amplifier		126
Modular Pulse Processing Electronics / NIM / Attenuators			127
N858	Dual Attenuator		127
Modular Pulse Processing Electronics / NIM / Coincidence/Logic/Trigger Units			127
N405	Triple 4-Fold Logic Unit/Majority with VETO		127
N113	Dual OR 12 In - 2 Out		127
N455	Quad Coincidence Logic Unit		128
Modular Pulse Processing Electronics / NIM / Discriminators			128
N605	4 Channel 200 MHz Constant Fraction Discriminator	NEW	128
N842 - N843	8/16 Channel Constant Fraction Discriminators		129
N840 - N841	8/16 Channel Leading Edge Discriminators		129
N844 - N845	8/16 Channel Low Threshold Discriminators		129
Modular Pulse Processing Electronics / NIM / Fan In-Fan Out			130
N454	4 - 8 Logic Fan In-Fan Out		130
N625	Quad Linear Fan In-Fan Out		130
Modular Pulse Processing Electronics / NIM / Scalers			130
N1145	Quad Scaler and Preset Counter / Timer		130
Modular Pulse Processing Electronics / NIM / Timing Units			131
N93B	Dual Timer		131
N108A	Dual Delay		131
Modular Pulse Processing Electronics / NIM / Translators			131
N89	NIM - TTL - NIM Adapter		131
N638	16 Channel NIM-ECL/ECL-NIM Translator and Fan Out		132
Modular Pulse Processing Electronics / VME			133
Modular Pulse Processing Electronics / VME / ADCs (Peak Sensing)			134
V1785	8 Channel Dual Range Multievent Peak Sensing ADC		134
V785 - V785N	32/16 Channel Multievent Peak Sensing ADC		134
Modular Pulse Processing Electronics / VME / Amplifiers (Fast)			135
V974	4 Channel Variable Gain Fast Amplifier		135
V975	8 Channel Fast Amplifier		135
Modular Pulse Processing Electronics / VME / Attenuators			135
V859	Dual Attenuator		135
Modular Pulse Processing Electronics / VME / Coincidence/Logic/Trigger Units			136
V2495	Programmable Logic Unit	NEW	136
A395A	32 LVDS/ECL/PECL input channels (Piggyback board)		137
A395B	32 LVDS output channels (Piggyback board)		137
A395C	32 ECL output channels (Piggyback board)		137

A395D	8 NIM/TTL input/output channels (Piggyback board)		137
A395E	8 Analog output 16-bit channels (Piggyback board)		137
V976	Quad 4 Fold AND/OR/MAJ, NIM-TTL TTLNIM Translator, Fan-In Fan-Out		138
Modular Pulse Processing Electronics / VME / Scaler Firmware			138
FW495SC	128 Ch Multievent Latching Scaler		138
Modular Pulse Processing Electronics / VME / Controllers			139
V1718 - VX1718	VME/VME64X VME-USB 2.0 bridge		139
V2718 - VX2718	VME/VME64X VME-PCI Optical Link Bridges		140
Modular Pulse Processing Electronics / VME / Discriminators			141
V814	16 Channel Low Threshold Discriminator		141
V812	16 Channel Constant Fraction Discriminator		141
V895	16 Channel Leading Edge Discriminator		142
Modular Pulse Processing Electronics / VME / Fan In-Fan Out Units			142
V925	Quad Linear Fan In-Fan Out		142
Modular Pulse Processing Electronics / VME / I/O Registers			143
V977	16 Channel I/O Register (Status A)		143
Modular Pulse Processing Electronics / VME / QDCs			143
V792 - V792N	32/16 Channel Multievent QDC		143
V862	32 Channel Multievent Individual Gate QDC		144
V965 - V965A	16/8 Channel Dual Range Multievent QDC		144
Modular Pulse Processing Electronics / VME / Scalers			145
V830	32 Channel Latching Scaler		145
Modular Pulse Processing Electronics / VME / TDCs			145
V1190 - 2eSST Family	128/64 Channel Multihit TDC (100/200/800 ps)		145
V1290 - 2eSST Family	32/16 Channel Multihit TDC		146
V775 - V775N	32/16 Channel Multievent TDC		147
Modular Pulse Processing Electronics / VME / Timing Units			147
V972	Delay Unit		147
V993C	Dual Timer		148
Modular Pulse Processing Electronics / VME / Translators			148
V538A	8 Channel NIM-ECL/ECL-NIM Translator		148
Modular Pulse Processing Electronics / Preamplifiers			149
Modular Pulse Processing Electronics / Preamplifiers / Charge Sensitive Preamplifiers			150
A422A	Charge Sensitive Preamplifier with Timing		150
A1422H	Low Noise Fast Rise Time Charge Sensitive Preamplifiers (Hybrid)		150
A1422	Low Noise Fast Rise Time Charge Sensitive Preamplifiers		151
A1424	Scintillation Preamplifier		152
Modular Pulse Processing Electronics / Preamplifiers / Fast Preamplifiers			152
A1425	Fast Charge Preamplifier	NEW	152
A1426 CARDARELLI	Matched Preamplifier	CS	153
Modular Pulse Processing Electronics / Preamplifiers / Wideband Amplifier			153
A1423B	Wideband Amplifier		153
Modular Pulse Processing Electronics / Preamplifiers / Preamplifier Power Supplies			154
N5424	Quad NIM Power distributor		154
DT5423	Quad Desktop Power distributor		154
Modular Pulse Processing Electronics / Powered Crates			155
Modular Pulse Processing Electronics / Powered Crates / Introduction to CAEN Powered Crates			156
Modular Pulse Processing Electronics / Powered Crates / VME Enhanced Crate series			158
VME8100	8U 21 Slot VME64/64X Enhanced Crate Series		158
VME8200	9U 21 Slot VME64X Enhanced Crate Series		160
Modular Pulse Processing Electronics / Powered Crates / VME Low Cost Crates			162
VME8010 - VME8011	7U 21 Slot VME64 Low Cost Crates		162
Modular Pulse Processing Electronics / Powered Crates / VME Mini Crate Series			163
VME8001	1U 2 Slot VME64 Mini Crate		163
VME8004B	2U 4 Slot VME64 Mini Crate		163
VME8004X	2U 4 Slot VME64X Mini Crate	NEW	164
VME8008B	4U 8 Slot VME64 Mini Crate		164

VME8008X	4U 8 Slot VME64X Mini Crate	NEW	165
Modular Pulse Processing Electronics / Powered Crates / NIM Crates			166
NIM8301	7U 12 Slot Smart Fan Unit 300/600 W Crate		166
NIM8303	5U 12 Slot 300/600 W Crate		168
NIM8302	5U 10 Slot 150 W Compact Crate		170
Modular Pulse Processing Electronics / Powered Crates / NIM Mini Crate Series			171
NIM8305	2 Slot Switching 430 W Mini Crate		171
NIM8306	2 Slot Switching 720 W Mini Crate		171
Modular Pulse Processing Electronics / Powered Crates / NIM Switching Crates			172
NIM8304	7U 12 Slot Smart Fan Unit Switching 2000 W Crate		172
Modular Pulse Processing Electronics / Powered Crates / Mixed Powered Crates			174
NV8020A	7U Crate VME/NIM 8 Slot VME64 365W, 5 Slot NIM 150W		174
Modular Pulse Processing Electronics / Powered Crates / Accessories			176
N8315	NIM Linear Power Supply 150W		176
A83xx	General Purpose 1U Fan Unit	NEW	176

			ST	pag
Digital Spectroscopy				177
Digital Spectroscopy / Digital Multichannel Analyzers				178
HEXAGON	Dual Digital Multichannel Analyzer (HV & Preamplicator PS - LCD) - Desktop	CS	178	
DT5780	Dual Digital Multichannel Analyzer (HV & Preamplicator PS) - Desktop		179	
N6780	Dual Digital Multichannel Analyzer (HV & Preamplicator PS) - NIM		179	
DT5781	Dual/Quad Digital Multichannel Analyzer - Desktop	NEW	181	
N6781	Dual/Quad Digital Multichannel Analyzer - NIM	NEW	181	
DT5770	Digital Multichannel Analyzer - Desktop	NEW	182	
Digital Spectroscopy / Digital Pulse Analyzers				183
DT5790	Dual Digital Pulse Shape Discriminator		183	
Digital Spectroscopy / Stand-Alone MCA Tube Base				184
Gamma <i>stream</i>	Active, stand-alone, fully featured MCA tube base for scintillation	NEW	184	
Digital Spectroscopy / Software				185
GammaTOUCH	Gamma <i>stream</i> Control Software for Android™		185	
DPP-PSD Control Software	Graphical Interface for DPP-PSD Management		185	
MC ² Analyzer (MC ² A)	Digital MCA Data Acquisition and Analysis Software		185	

			ST	pag
CAEN Educational				187
SP5600C - SP5600D SP5600E - SP5600AN	Nuclear and Modern Physics Kits	NEW	188	
SP5700	EasyPET	CS	189	
SP5600EMU	Emulation Kit	NEW	190	

			ST	pag
Readout Systems				191
SY2791	Liquid Argon TPC Readout System		192	
A2795	Liquid Argon TPC Readout Board	NEW	194	
DPP-CRAMS - FW1495GRAMS	CAEN Readout System for Multiplexed Signals		195	
DT5550	32 Channel DAQ System with Programmable FPGA and Sequencer	CS	196	
A1702	32 Channel Silicon Photomultipliers Readout Front-End Board	NEW	197	

Digital Detector Emulators

199

Digital Detector Emulators / Introduction to Digital Detector Emulator 200

Digital Detector Emulators / Applications 202

DT5810	Desktop Fast Digital Detector Emulator	NEW	203
DT4800	Micro Digital Detector Emulator	NEW	204
NDT6800	NIM/Desktop Digital Detector Emulator		205
DT5800	Desktop Digital Detector Emulator		205

Accessories

207

A2818	PCI CONET Controller		208
A3818	PCI Express CONET2 Controller		208
A1481	Kill Signal Adapter for N14xx Series		208
A385 - A392	16 Channel LEMO Adapters		208
A654	MCX to LEMO Cable Adapters		208
A659	MCX to BNC Cable Adapters		208
A746B	64 Channel Adapter for LEMO Connector (VME)		209
A746D	32 Channel Adapter for LEMO Connector (NIM)		209
A746E	32 Channel Adapter for LEMO Connector (DT)		209
A954	16 Channel to 2x8 Channel Cable Adapter		209
A967	32 Channel Cable Adapter for V767, V862, V1190, VX1190, Vx495, DT5495		209
A992	16 Channel Impedance Adapter		209
N1568ADAT	USB RS485 Adapter Board		209
A995	Insertion/Extraction Tool for A996		210
A996	52 Pin Cable Connector		210
A997	HV Coaxial Cable Connector for CPE HV		210
A309 - A310 - A311 - A312 A313	Single Channel Fixed Attenuators		210
AI2700	Optical Fiber Series		210
A483	HV Bidirectional Passive HV Filter		210
A315	Splitter		211
A317	Clock Distribution Cable		211
A318	Single-Ended to Differential Cable Adapter		211
A1015x - A64x - R64x	HV Adapters (DB37 and Radiall to SHV cable)		211
A83xx	General Purpose 1U Fan Unit	NEW	211

Connectors

213

Cross Reference Tables

218

T1	Universal Multichannel Systems - Mainframes	218
T2	Universal Multichannel Systems - Individual Floating Channel Boards	218
T3	Universal Multichannel Systems - Common Ground Boards	219
T4	Universal Multichannel Systems - Common Floating Return Boards	219
T5	VME High Voltage Power Supplies	220
T6	NIM High Voltage Power Supplies	220
T7	Desktop High Voltage Power Supplies	221
T8	PCB High Voltage Power Supplies	221
T9	Powered Crates	222

T10	ADCs (Peak Sensing)	222
T11	Digitizers	223
T12	Amplifiers (Fast)	223
T13	Amplifiers (Spectroscopy)	224
T14	Attenuators	224
T15	Charge Sensitive Preamplifiers	224
T16	Charge Sensitive Preamplifiers (Scintillation Detectors)	224
T17	Fast Preamplifiers	224
T18	Coincidence/Logic/Trigger Units	224
T19	Controllers	225
T20	Discriminators	225
T21	Fan In-Fan Out Units	225
T22	I/O Registers	226
T23	QDCs	226
T24	Scalers	226
T25	TDCs	226
T26	Timing Units	227
T27	Translators	227
T28	Desktop/Portable Digital MCAs	227
T29	NIM Digital MCAs	228

Precautions for Handling, Storage and Installation

pag

229

Product Index

pag

230

Functional Index

pag

240

Sales Network

pag

249

Legend



Indicates that Linux OS is supported



Indicates that Windows OS is supported. Windows® is a registered trademark of Microsoft Corporation in the United States and other countries.



Indicates that Android™ OS is supported. Android is a trademark of Google Inc.



Indicates that the App is available on Google Play™. Google Play and the Google Play logo are trademarks of Google Inc.



Indicates that LabVIEW™ is supported. LabVIEW™ is a trademark of National Instruments. Neither CAEN, nor any software programs or other goods or services offered by CAEN, are affiliated with, endorsed by, or sponsored by National Instruments.



**FREE
DOWNLOAD**

Indicates that the Product is available for free download



**FREE TRIAL
VERSION**

Indicates that a Firmware trial version is available for free download



Indicates that the Product is supported by CAEN OPC Server



Indicates that the Product is supported by CAEN HV Wrapper library



Indicates that the Product can be controlled by CAEN HiVoCS web based software



Indicates that the Product is supported by a LabVIEW™ Instrument Driver



Indicates that the Product can be controlled by CAEN GECO2020 software



Indicates that the Product is supported by an EPICS Input Output Controller

NEW

colour red = Indicates a New Product

**COMING
SOON**

colour green = Indicates a Coming Soon Product *

* The specifications description is a draft version only. The content is still under internal review and subject to formal approval, which may result in modifications or additions.



Indicates that the Product can be controlled by CAEN SY Smart Touch software



Indicates that the Digitizer can run Waveform Recording firmware



Indicates that the Digitizer can run Digital Pulse Processing for Pulse Height Analysis (DPP-PHA) firmware



Indicates that the Digitizer can run Digital Pulse Processing for Pulse Shape Discrimination (DPP-PSD) firmware



Indicates that the Digitizer can run Digital Pulse Processing for Charge to Digital Conversion (DPP-QDC) firmware



Indicates that the Digitizer can run Digital Pulse Processing for Zero Length Encoding (DPP-ZLEplus) firmware



Indicates that the Digitizer can run Digital Pulse Processing for Dynamic Acquisition Window (DPP-DAW) firmware



Indicates that the Product can be controlled by CAENSCOPE software



Indicates that the Product can be controlled by CAEN WaveDump software



Indicates that the Product can be controlled by CAEN WaveCatcher software



Indicates that the Product can be controlled by CAEN CoMPASS software



Indicates that the Product can be controlled by CAEN MC²Analyzer software



Indicates that the Product can be controlled by CAEN GammaTOUCH software

Legend (continued)



Indicates that the Product can be controlled by CAEN
DPP-PSD Control Software



Indicates that the Product can be controlled by CAEN
DPP-QDC demo software



Indicates that the Product can be controlled by CAEN
DPP-ZLEplus demo software



Indicates that the Product can be controlled by CAEN
DPP-DAW demo software



Indicates that the Product is supported by CAEN
Upgrader software



Indicates that the Product is supported by CAEN
VME Demos software



Indicates that the Product can run CAEN FW495SC
128 Ch Multievent Latching Scaler firmware



Indicates that the Product can be controlled by CAEN
Detector Emulator Control Center

Products:

Power Supplies

Modular Pulse Processing Electronics

Digital Spectroscopy

Educational Kits

Readout Systems

Digital Detector Emulators

Accessories / Adapters

Applications:

High Energy Physics

Astrophysics

Neutrino Physics

Dark Matter Investigation

Nuclear Physics

Material Science

Medical Applications

Homeland Security

Industrial Applications



Electronic Instrumentation

CAEN SpA is acknowledged as the only company in the world providing a complete range of High/Low Voltage Power Supply systems and Front-End/Data Acquisition modules which meet IEEE Standards for Nuclear and Particle Physics.

Extensive Research and Development capabilities allowed CAEN SpA to play an important long term role in this field. CAEN activities have always been at the forefront of technology, thanks to years of intensive collaborations with the most important Research Centres of the world.

CAEN products appeal to a wide range of customers including engineers, scientists and technical professionals who all trust them to achieve their goals faster and more effectively.

Strong of the experience in the physics research world CAEN instruments are today used in many advanced industrial applications.



Tools for Discovery

Costruzioni Apparecchiature Elettroniche Nucleari (C.A.E.N.) is one of the most important spin-offs of the Italian Institute of Nuclear Physics (INFN).

Founded in 1979 by a group of senior engineers from the INFN, is today world wide recognized as one of the leading companies in the electronics instrumentation field.

CAEN Network Companies is a micro-cluster of companies with excellence know how.

CAEN Netwo



CAEN qS designs, organizes and implements "state of the art" solutions for Information Security and assists organizations in managing and controlling the critical infrastructures for protection at the highest possible standard.





ork Companies



CAEN RFID is today a leading supplier of UHF RFID readers and tags. It has been among the first European companies to design and manufacture UHF RFID readers.



CAEN ELS is a leading company in the design of power supplies and state-of-the-art complete electronic systems for the Physics research world, having its main focus on dedicated solutions for the particle accelerator community and high-end industrial applications.

Thanks to the longstanding engineering, manufacturing and maintenance experience of CAEN Spa, CAEN ELS has become a strategic and reliable partner for the community, being able to integrate its products and solutions with direct support to the customers and their installations.

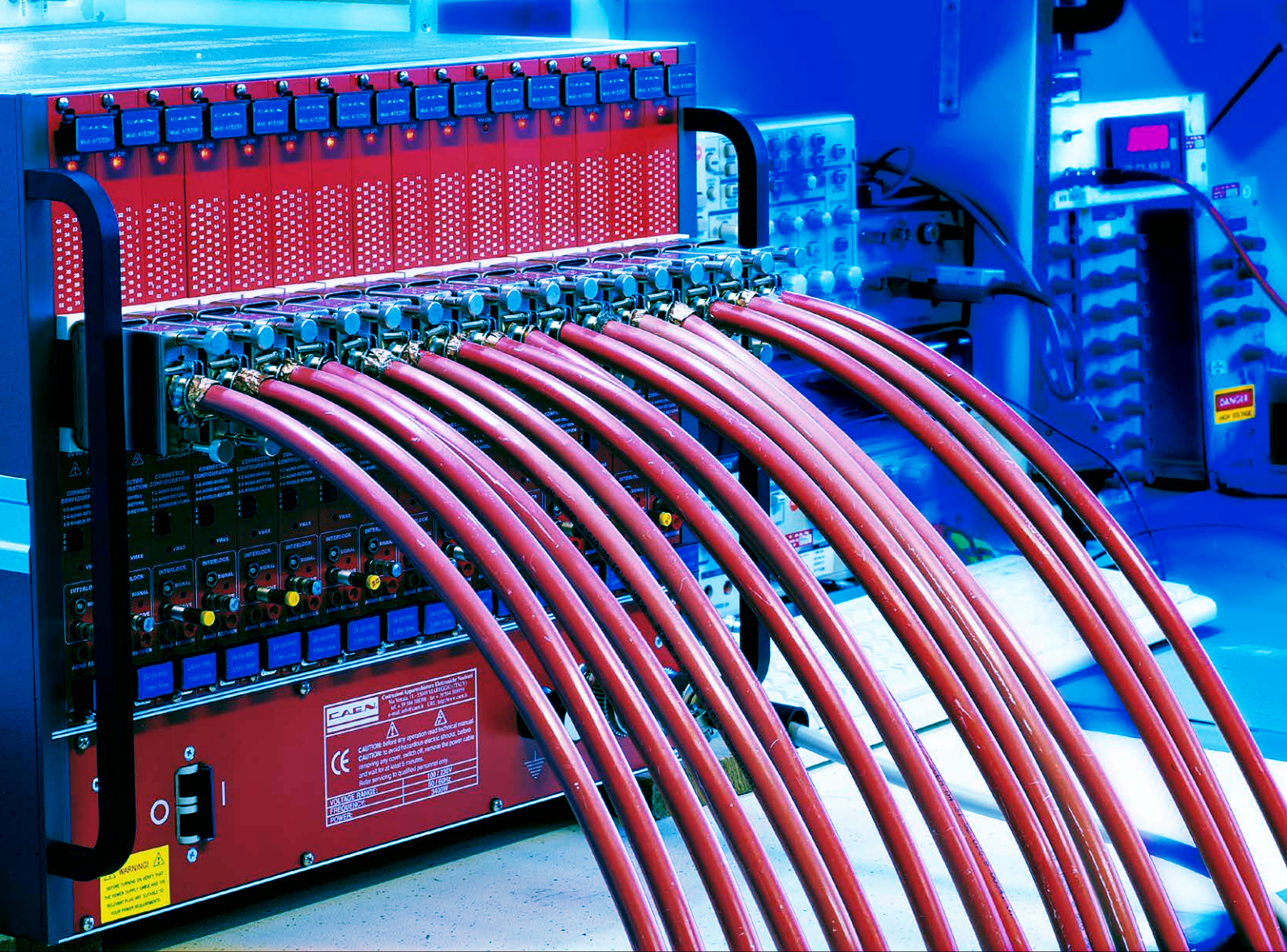

POWER SUPPLIES

CAEN Power Supplies: a perfect blend of tradition and innovation

The Power Supply Systems are at the heart of any experiment. They provide the High Voltage and Low Voltage required by the detectors and by the related front-end electronics.

- Universal Multichannel Systems
- VME-NIM Power Supplies
- Standalone Power Supplies
- EASY (Embedded Assembly System)
- High Power Low Voltage System
- Power Supply Control Software

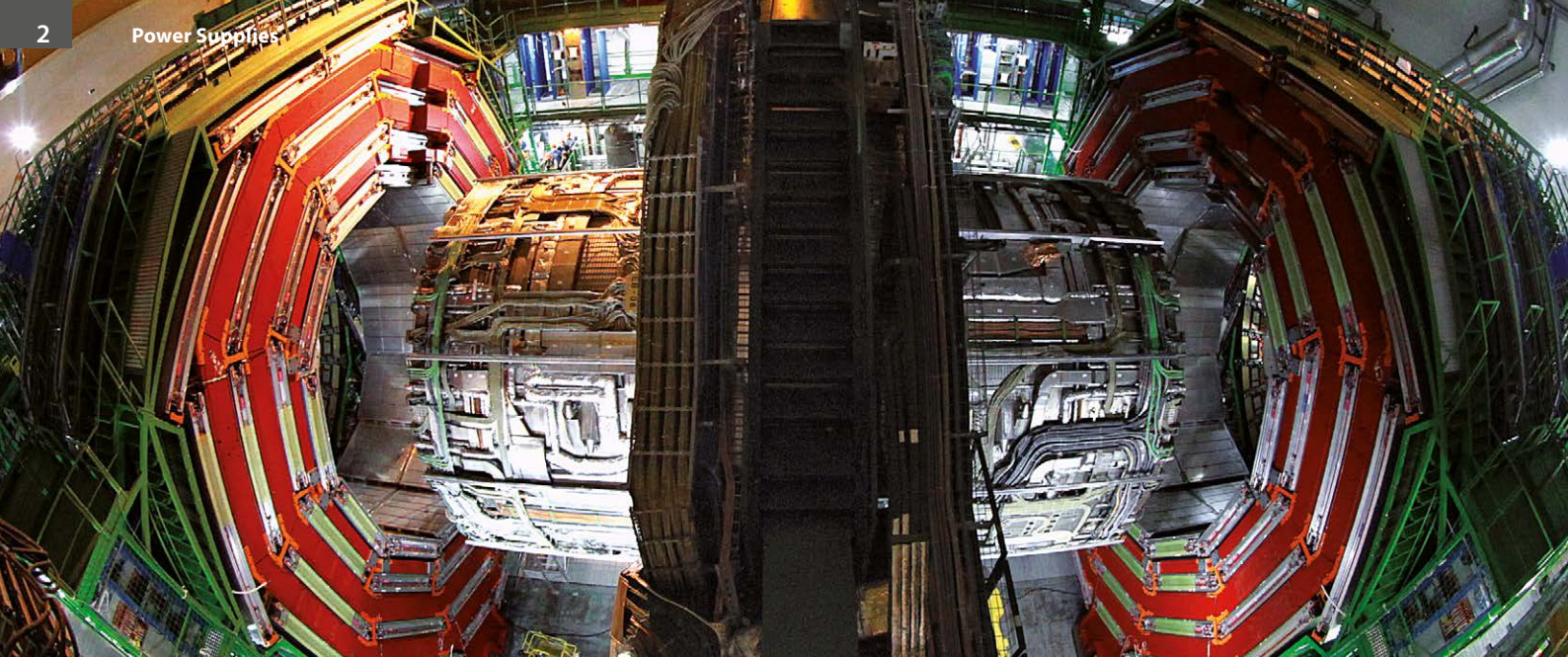

Introduction to High and Low Voltage Power Supplies

High and low voltages are expressions difficult to define in an univocal way. In the research community and in the electrical and electrotechnical industry the meaning of high and low voltage may be quite different depending on the considered application.

In the United States 2014 National Electrical Code (NEC), high voltage is defined as any voltage over 1000 V (article 490.2), while the International Electrotechnical Commission and its national counterparts (IET, IEEE, VDE, etc.) defines High and Low Voltages as follows:

	AC	DC
High Voltage (HV)	> 1000 V	> 1500 V
Low Voltage (LV)	50 – 1000 V	120 – 1500 V
Extra Low Voltage (ELV)	< 50 V	< 120 V
Safety ELV (SELV)	25 V	60 V

In the scientific community and in related industrial activities the difference between low and high voltage is almost always related to the specific application. When talking about particle detectors, “high voltage” is used to create an electric field that allows to amplify the signal produced by the particle when interacting with the detector material.

Therefore, the same “high voltage” expression might mean the 6 kV needed to power a Germanium detector, the 3 kV for a photomultiplier as well as the few hundred volts for providing the reverse bias to a silicon detector. In a similar way, “low voltage” is used to power the analog and digital electronics integrated in the detectors or for other similar applications.

A power supply is an electronic device that supplies electric energy to an electrical load. The primary function of a power supply is to convert one form of electrical energy to another and, as a result, power supplies are sometimes referred to as electric power converters. Power supplies are categorized in various ways, including by functional features, are packaged in different ways and classified accordingly and can be broadly divided into linear and switching types.

All CAEN power supplies are the results of 35 years of experience

side by side with the research community. All of them features:

- Modularity
- High reliability
- Mechanic solidness
- High performance
- Hardware and software protection against failures like over currents, over/under voltage, shorts
- Remote and local control
- Dedicated control software

Introduction to Power Supplies working principles

A voltage regulator is an electrical component designed to automatically maintain a constant voltage level. It can be made by a simple “feed-forward” design or may include negative feedback control loops. It may use an electromechanical mechanism, or electronic components.

Depending on the design, it may be used to regulate one or more AC or DC voltages. A simple voltage regulator can be made from a resistor in series with a diode (or series of diodes). Due to the logarithmic shape of diode V-I curves, the voltage across the diode changes only slightly due to changes in current drawn or changes in the input. When precise voltage control and efficiency are not important, this design may work fine.

Feedback voltage regulators operate by comparing the actual output voltage to some fixed reference voltage. Any difference is amplified and used to control the regulation element in such a way as to reduce the voltage error. This forms a negative feedback control loop; increasing the open-loop gain tends to increase regulation accuracy but reduce the stability.

There will also be a trade-off between stability and the speed of the response to changes. If the output voltage is too low, the regulation element acts in order to produce a higher output voltage—by dropping less of the input voltage (for linear series regulators and buck switching regulators), or to draw input current for longer periods (boost-type switching regulators); if the output voltage is too high, the regulation element will normally be commanded to produce a lower voltage. However, many regulators have over-current protection, so



Introduction to High and Low Voltage Power Supplies

that they will entirely stop sourcing current (or limit the current in some way) if the output current is too high. Some regulators may also shut down if the input voltage is outside a given range.

"Voltage regulator" Wikipedia: The Free Encyclopedia. Wikimedia Foundation, Inc. 22 July 2004. Web. 10 Aug. 2004.

Linear Power Supplies

In electronics, a linear regulator is a system used to maintain a steady voltage. The resistance of the regulator varies in accordance with the load resulting in a constant output voltage. The regulating device is made to act like a variable resistor, continuously adjusting a voltage divider network to maintain a constant output voltage, and continually dissipating the difference between the input and regulated voltages as waste heat. Since the regulated voltage of a linear regulator must always be lower than input voltage, efficiency is limited and the input voltage must be high enough to always allow the active device to drop some voltage.

Linear regulators may place the regulating device in parallel with the load (shunt regulator) or may place the regulating device between the source and the regulated load (a series regulator). Simple linear regulators may only contain a Zener diode and a series resistor; more complicated regulators include separate stages of voltage reference, error amplifier and power pass element.

"Linear regulator" Wikipedia: The Free Encyclopedia. Wikimedia Foundation, Inc. 22 July 2004. Web. 10 Aug. 2004.

Switching Power Supplies

A switched-mode power supply is an electronic power supply that incorporates a switching regulator to convert electrical power efficiently. Like other power supplies, it transfers power from a source to a load, while converting voltage and current characteristics. Unlike a linear power supply, the pass transistor of a switching-mode supply continually switches between low-dissipation, full-on and full-off states, and spends very little time in the high dissipation transitions, which minimizes wasted energy. Ideally, a switched-mode power supply dissipates no power. Voltage regulation is achieved by varying the ratio of on-to-off time. This

higher power conversion efficiency is an important advantage of a switched-mode power supply.

Moreover they also may be substantially smaller and lighter than a linear supply due to the smaller transformer size and weight. Switching regulators are used as replacements for linear regulators when higher efficiency, smaller size or lighter weight are required. They are, however, more complicated; their switching currents can cause electrical noise problems if not carefully suppressed, and simple designs may have a poor power factor.

"Switched-mode power supply" Wikipedia: The Free Encyclopedia. Wikimedia Foundation, Inc. 22 July 2004. Web. 10 Aug. 2004.

Linear and Switching Power Supplies: a comparison

Its not trivial to choose the proper power supply for a specific application. In many cases the final decision is a compromise between the advantages and the drawbacks of the two technologies. In the following, we perform a quick comparison between Linear and Switching power supplies:

- Size and Weight
 - Linear Power Supplies: Heatsinks for high power linear regulators and large transformers due to low operating frequency are large and add size and weight
 - Switching Power Supplies: Smaller transformer due to higher operating frequency. Size and weight of adequate RF shielding may be significant.
 - Linear Power Supplies: any voltage available, if a transformer is used; if transformerless, limited to what can be achieved with a voltage doubler. If unregulated, voltage varies significantly with load.
 - Switching Power Supplies: any voltage available, limited only by transistor breakdown voltages in many circuits. Voltage varies little with load.
- Efficiency, heat and power dissipation:
 - Linear Power Supplies: if regulated, the efficiency largely depends on voltage difference between input and output; output voltage is regulated by dissipating excess power as heat resulting in a typical efficiency of 30-40%. If unregulated, transformer iron and copper losses may be the only significant sources of inefficiency.

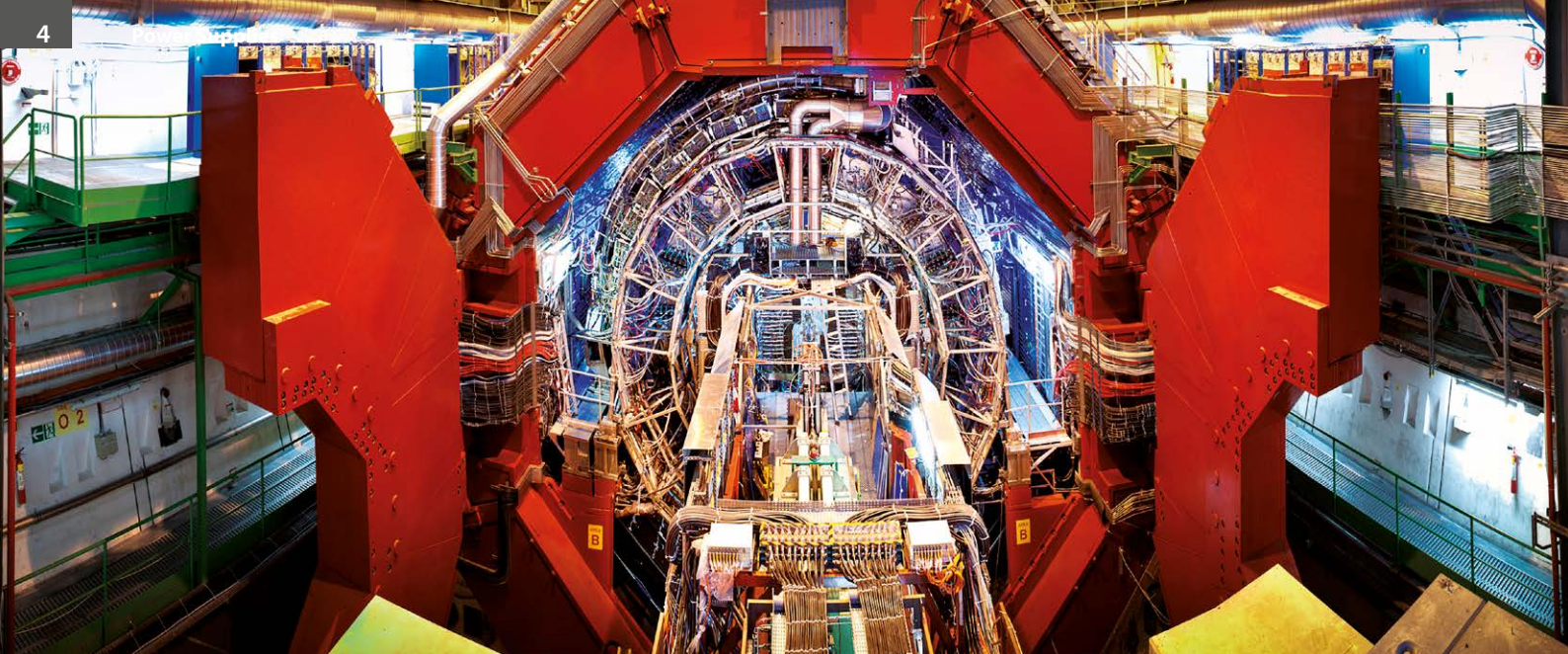

Introduction to High and Low Voltage Power Supplies

- Switching Power Supplies: output is regulated using duty cycle control; the transistors are switched fully on or fully off, so very little resistive losses between input and the load. The only heat generated is in the non-ideal aspects of the components and quiescent current in the control circuitry.
- Radio frequency Interference
 - Linear Power Supplies: mild high-frequency interference may be generated by AC rectifier diodes under heavy current loading, while most other supply types produce no high-frequency interference.
 - Switching Power Supplies: EMI/RFI produced due to the current being switched on and off sharply. Therefore, EMI filters and RF shielding are needed to reduce the disruptive interference.
 - Linear Power Supplies: Unregulated power supplies may have a little AC ripple superimposed upon the DC component at twice mains frequency (100–120 Hz).
 - Switching Power Supplies: Noisier due to the switching frequency. An unfiltered output may cause glitches in digital circuits or noise in analog circuits.
- Noise at the input terminals
 - Linear Power Supplies: causes harmonic distortion to the input AC, but relatively little or no high frequency noise.
 - Switching Power Supplies: very low cost power supplies may couple electrical switching noise back onto the mains power line, causing interference with any electronic equipment connected to the same phase. Non power-factor-corrected SMPSs also cause harmonic distortion.
- Power Factor
 - Linear Power Supplies: Low for a regulated supply because current is drawn from the mains at the peaks of the voltage sinusoid, unless a choke-input or resistor-input circuit follows the rectifier.
 - Switching Power Supplies: ranging from very low to medium since a simple SMPS without PFC draws current spikes at the peaks of the AC sinusoid.

“Switched-mode power supply” Wikipedia: The Free Encyclopedia. Wikimedia Foundation, Inc. 22 July 2004. Web. 10 Aug. 2004.

Providing power over Long Distances: the Voltage Drop Issue

Voltage drop describes how the supplied energy of a voltage source is reduced as electric current moves through the passive elements of an electrical circuit. Voltage drops across internal resistances of the source, across conductors, across contacts, and across connectors are undesired because supplied energy is dissipated and lost. If the voltage drop is too high the operation of the electrical equipment involved could be compromised. In electronic design and power transmission, various techniques are employed to compensate for the effect of voltage drop on long circuits or where voltage levels must be accurately maintained.

The simplest way to reduce voltage drop is to increase the diameter of the conductor between the source and the load, which lowers the overall resistance but with the but the drawbacks of higher costs and larger cable capacitance. In power distribution systems, a given amount of power can be transmitted with less voltage drop if a higher voltage is used.

More sophisticated techniques use active elements to compensate for the undesired voltage drop. In many cases the use of long cables cannot be avoided in particular when the power supplies have to be installed away from hostile environments or the space constraints become critical. In these conditions then main challenge is providing a stable low voltage levels at the load (as low as 1.5 - 2 V) over long distances, even hundred of meters without increasing the cable sections too much because the voltage drop along the cables could be considerably higher than the voltage required by the load.

Many parameters have to be taken into account when estimating if a setup is suitable in terms of stability and performances for the particular application. Among them the distance to cover, the cable capacitance and resistance, the voltage regulation time, voltage and current levels to be kept and so on.

CAEN has a deep experience in successfully providing long distance power supply and features its low voltage units with reliable solutions based on sense wires which allows a full compensation of the voltage drops along tens of meters cables. Some CAEN power supplies features the so called “Line Drop Recovery” (LDR) technology which allows through a digital control to avoid the use of the sense wires.

“Switched-mode power supply” Wikipedia: The Free Encyclopedia. Wikimedia Foundation, Inc. 22 July 2004. Web. 10 Aug. 2004.

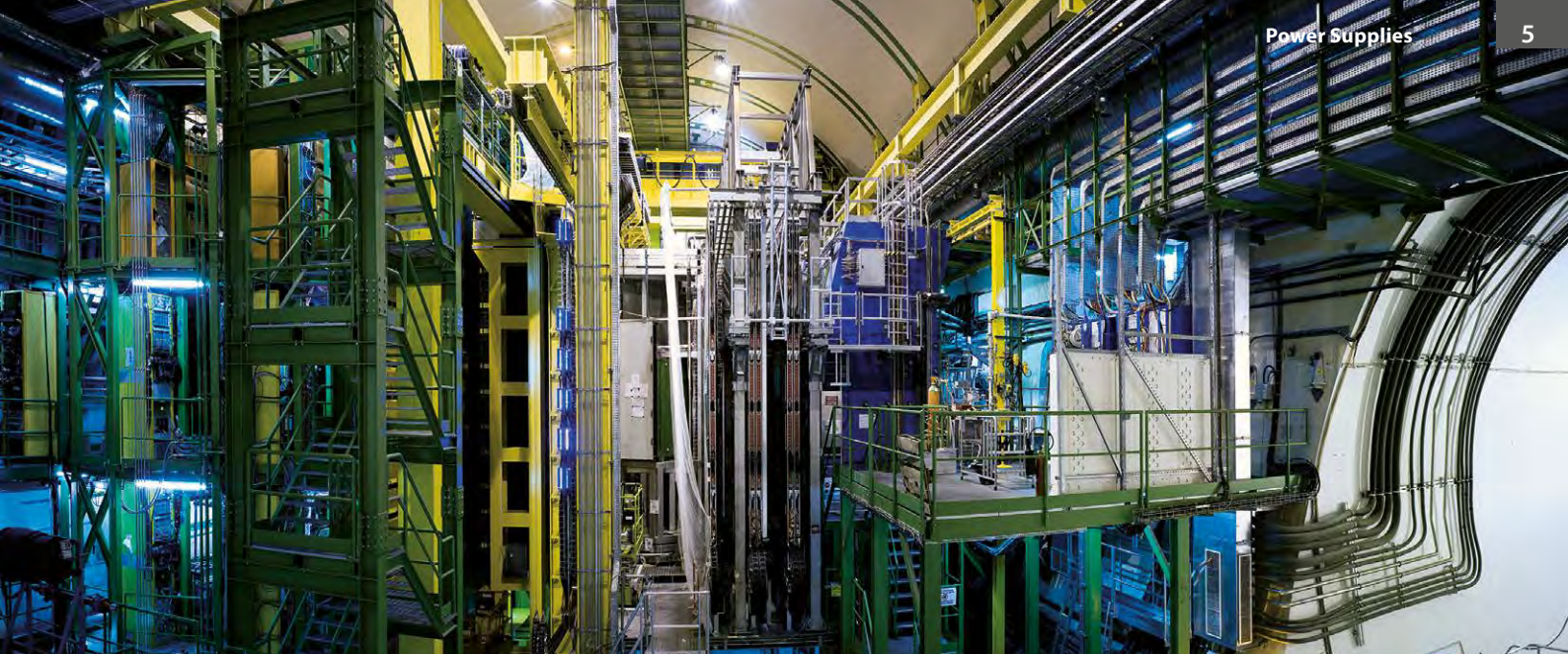

Introduction to High and Low Voltage Power Supplies

Power Supplies for Hostile Environment

In many specific application operating the power supplies close to the detector, even in a hostile environment, is much more convenient if not mandatory. This of course requires that the power supply is able to work inside the hostile conditions for a sufficient long time keeping the performances at the required level and with an high degree of reliability. Standard power supplies cannot work in magnetic field or radioactive environment, so for application that needs to be hosted inside such conditions special solution for the magnetic sensitive parts inside the power box and/or radiation tolerant solution have to be implemented. The CAEN EASY System is the answer to such a changeling request

Low Voltage Power Supplies

Power Supplies for Analog and Digital Front End Electronics

In modern physics experiments, every particle detector is equipped with built-in electronics in which, thanks to the always more effective miniaturization, more and more components are integrated. The main goal is to have a preprocessing of the detector signal as soon as possible in order to reduce the noise contamination and have a faster data processing. This complex electronics needs stable low voltages for analog and digital circuits. However the geometry, space constraints and often hostile environmental conditions lead to the use of cables whose length may range from centimeters to several hundreds of meters.

CAEN, thanks to its longstanding experience, provides suitable solution to all low voltage installation needs: constant voltage over long distances, magnetic and radiation tolerance capabilities for power supplies that must operate very close to detectors, multichannel HV/LV integrated systems, high power devices.

Low Voltage Power Supply Requirements

Typical Voltage	1.5 – 60 V
Typical Current	1 – 200 A
Polarity	Positive or Negative

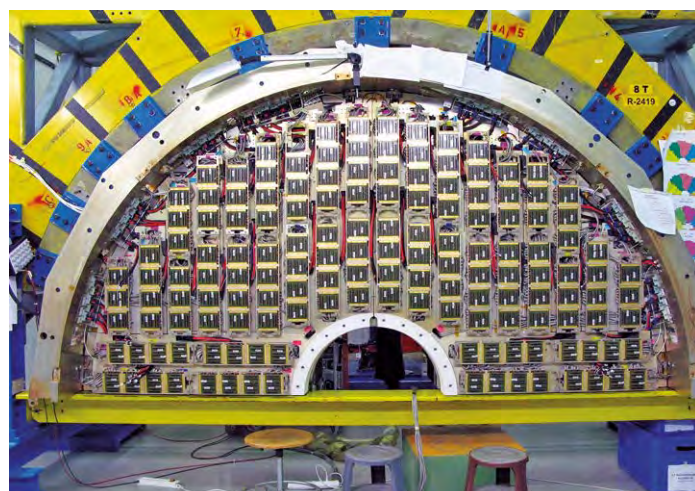

Figure A: Front end electronics for the MRPCs of the ALICE TOF. © 2006-2016 CERN

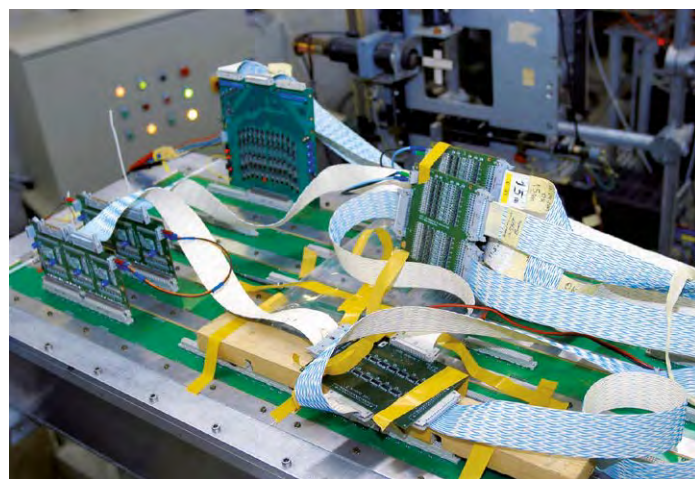
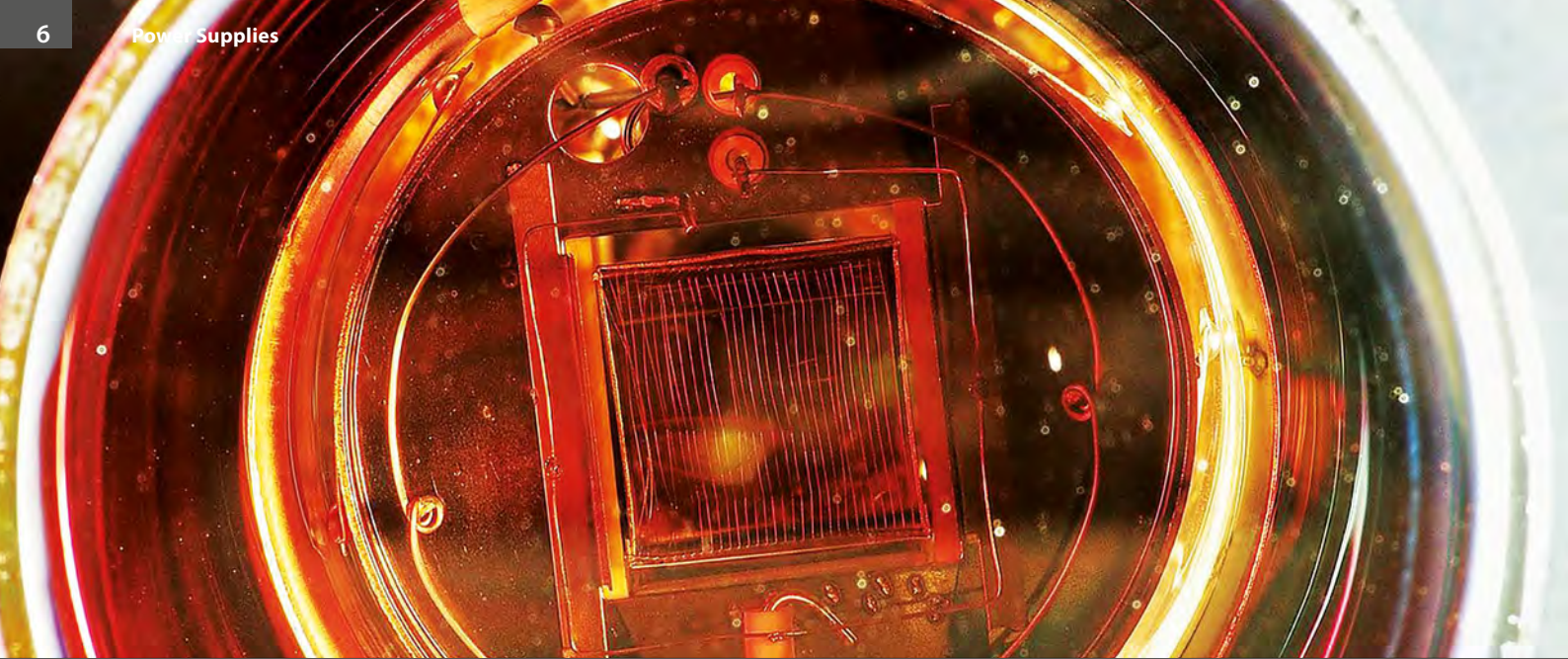

Figure B: CMS ECAL Endcap DEE 4 - Optical fibres and electronics © 2008 CERN, for the benefit of the CMS Collaboration



Introduction to High and Low Voltage Power Supplies

Power Supplies for Particle Detectors

Photomultipliers

Photomultiplier tubes are extremely sensitive detectors of light in the ultraviolet, visible, and near-infrared ranges of the electromagnetic spectrum. These detectors multiply the current produced by incident light by as much as 100 million times, in multiple dynode stages, enabling individual photons to be detected when the incident flux of light is very low.

Photomultipliers are typically constructed with an evacuated glass housing, containing a photocathode, several dynodes, and an anode. Incident photons strike the photocathode material, which is usually a thin vapor-deposited conducting layer on the inside of the entry window of the device. Electrons are ejected from the surface as a consequence of the photoelectric effect. These electrons are directed by the focusing electrode toward the electron multiplier, where electrons are multiplied by the process of secondary emission. The necessary distribution of voltage along the series of dynodes is created by a voltage divider chain.

Photomultiplier tubes typically utilize 1000 to 3000 volts to accelerate electrons within the chain of dynodes. Negative high-voltage supplies (with the positive terminal grounded) are often preferred. While powered, photomultipliers must be shielded from ambient light to prevent their destruction through overexcitation. If used in a location with strong magnetic fields photomultipliers are usually magnetically shielded by a

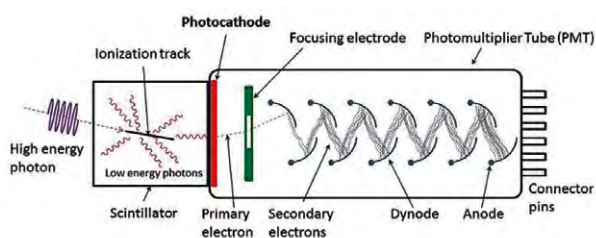

Figure 1: Schematic view of a scintillation detector coupled with a photomultiplier

layer of soft iron or mu-metal. The combination of high gain, low noise, high frequency response or, equivalently, ultra-fast response, and large area of collection has maintained photomultipliers an essential place in nuclear and particle physics, astronomy and medical diagnostics.

"Photomultiplier" Wikipedia: The Free Encyclopedia. Wikimedia Foundation, Inc. 22 July 2004. Web. 10 Aug. 2004.

PMTs Power Supply Requirements

Typical Voltage	1 – 3 kV
Typical Current	0.1 to 3 mA
Polarity	Positive or Negative

Photodiodes

A photodiode is a semiconductor device that converts light into current. The current is generated when photons are absorbed in the photodiode. When a photon of sufficient energy strikes the diode, it creates an electron-hole pair. This mechanism is also known as the inner photoelectric effect. If the absorption occurs in the junction's depletion region, or one diffusion length away from it, these carriers are swept from the junction by the built-in electric field of the depletion region. Thus holes move toward the anode, and electrons toward the cathode, and a photocurrent is produced.

The total current through the photodiode is the sum of the dark

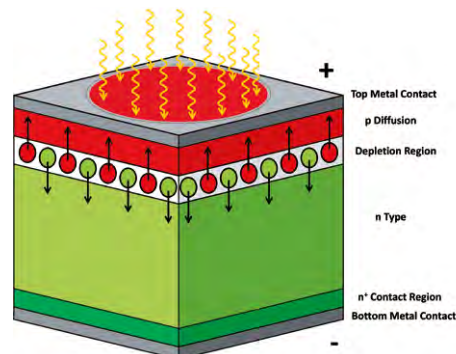
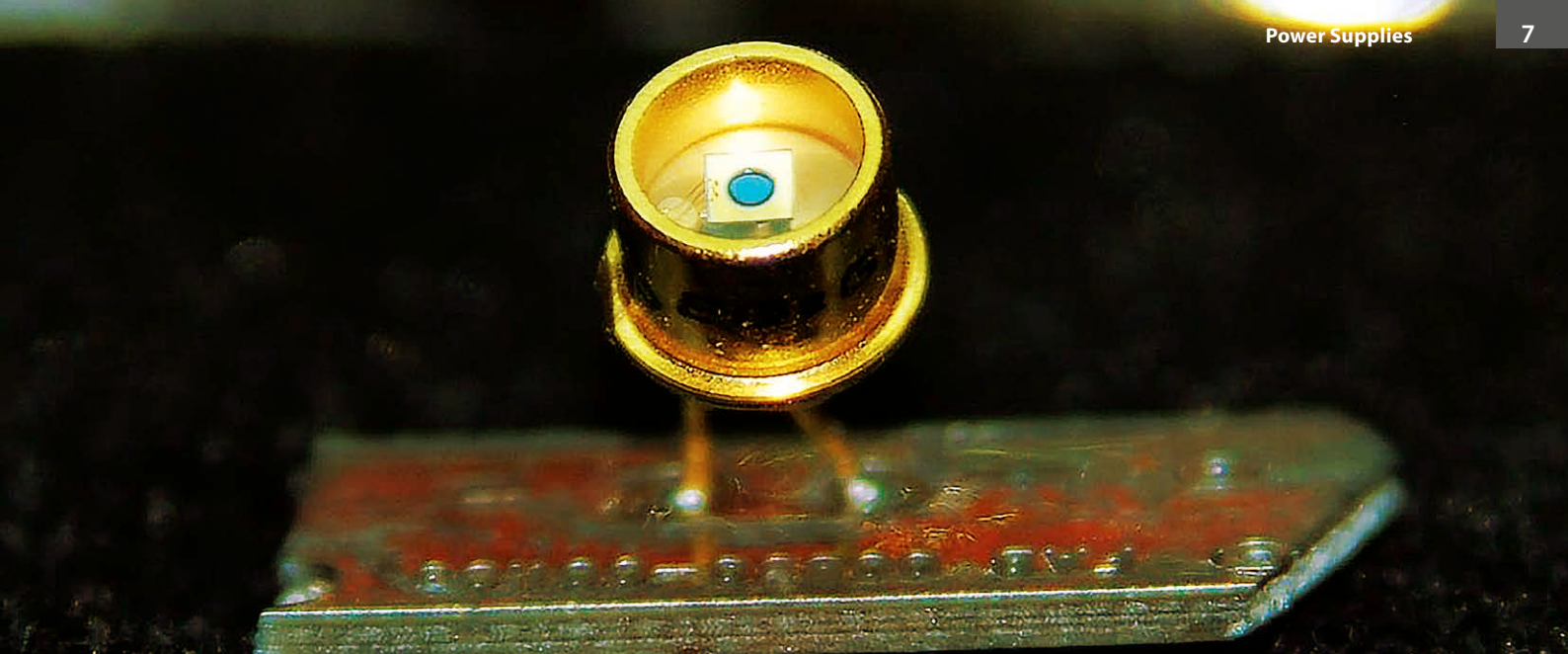

Figure 2: Schematic view of a photodiode working principle



Introduction to High and Low Voltage Power Supplies

current (current that is generated in the absence of light) and the photocurrent, so the dark current must be minimized to maximize the sensitivity of the device. When used in zero bias, the flow of photocurrent out of the device is restricted and a voltage builds up. When reverse biased, the depletion layer is widened and the reaction volume expanded.

"Photodiode" Wikipedia: The Free Encyclopedia. Wikimedia Foundation, Inc. 22 July 2004. Web. 10 Aug. 2004.

Photodiodes Power Supply Requirements	
Typical Voltage	5 V to 100 V
Typical Current	1 μ A to 10 mA
Polarity	Positive or Negative

Avalanche Photodiodes

An avalanche photodiode (APD) is a highly sensitive semiconductor electronic device that exploits the photoelectric effect to convert light to electricity. APDs can be thought of as photodetectors that provide a built-in first stage of gain through avalanche multiplication. From a functional standpoint, they can be regarded as the semiconductor analog to photomultipliers. By applying a high reverse bias voltage (typically 100-200 V in silicon), APDs show an internal current gain effect (around 100) due to impact ionization (avalanche effect).

However, some silicon APDs employ alternative doping and beveling techniques compared to traditional APDs that allow greater voltage to be applied (> 1500 V) before breakdown is reached and hence a greater operating gain (> 1000). In general, the higher the reverse voltage the higher the gain. If very high gain is needed (10^5 to 10^6), certain APDs (single-photon avalanche diodes) can be operated with a reverse voltage above the APD's breakdown voltage. In this case, the APD needs to have its signal current limited and quickly diminished.

Active and passive current quenching techniques have been used for this purpose. APDs that operate in this high-gain regime are in Geiger mode. This mode is particularly useful for single photon detection provided that the dark count event rate is sufficiently low.

"Avalanche Photodiode" Wikipedia: The Free Encyclopedia. Wikimedia Foundation, Inc. 22 July 2004. Web. 10 Aug. 2004.

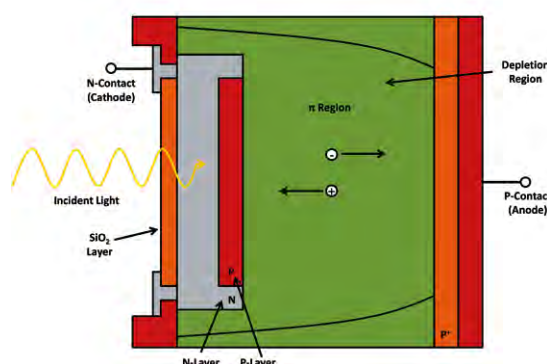

Figure 3: Schematic view of the APD working principle

APDs Power Supply Requirements	
Typical Voltage	50 – 2000 V
Typical Current (Anode)	1 – 10 mA
Polarity	Positive or Negative

Silicon photomultipliers

Silicon photomultipliers are silicon single photon sensitive devices built from an avalanche photodiode (APD) array on common silicon substrate. The dimension of each single APD can vary from 20 to 100 μ m and their density can be up to 1000 per square millimeter. Every APD in SiPM operates in Geiger-mode and is coupled with the others by a polysilicon quenching resistor.

Although the device works in digital/switching mode, the SiPM is an analog device because all the microcells are read in parallel making it possible to generate signals within a dynamic range from a single photon to 1000 photons per single square millimeter area device. The supply voltage depends on APD technology used, and typically varies between 20 V and 100 V, thus being from 15 to 75 times lower than the voltage required for a traditional photomultiplier tubes (PMTs) operation.

Photo detection efficiency ranges from 20-50% depending on device and wavelength, being similar to a traditional PMT. The gain is also

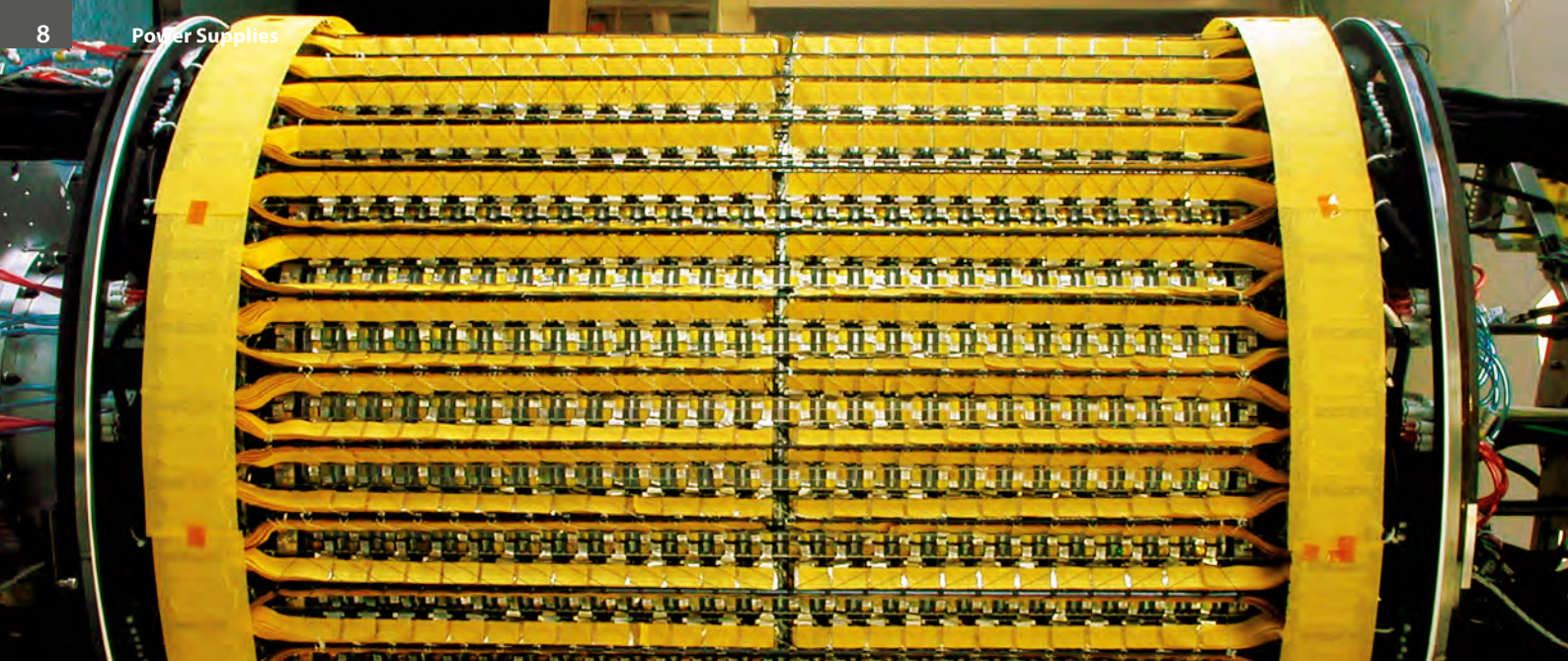

Introduction to High and Low Voltage Power Supplies

similar to a PMT being approximately 10^6 while the G/V dependence is linear and does not follow a power law like in the case of PMTs. The signal parameters are practically independent of external magnetic fields and the small dimensions permits extremely compact, light and robust mechanical design.

"Silicon Photomultiplier" Wikipedia: The Free Encyclopedia. Wikimedia Foundation, Inc. 22 July 2004. Web. 10 Aug. 2004.

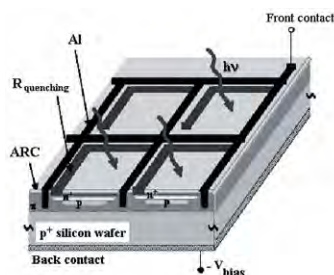

Figure 4: Schematic view of the Silicon PM

Silicon PMs Power Supply Requirements

Typical Voltage	25 V to 70 V
Typical Current (Anode)	10 to 30 mA
Typical Voltage (electronics)	5 V
Typical Current (electronics)	40 to 100 mA
Polarity	Positive or Negative

Silicon Strips, Drift and Pixel Detectors

Semiconductor detectors are also a very useful tool to detect charged particles. In semiconductor detectors, ionizing radiation is measured by the number of charge carriers set free in the detector material which is arranged between two electrodes, by the radiation. Ionizing radiation produces free electrons and holes. The number of electron-hole pairs is proportional to the energy of the radiation to the semiconductor. As a result, a number of electrons are transferred from the valence band to the conduction band, and an equal number of holes are created in the valence band. Under the

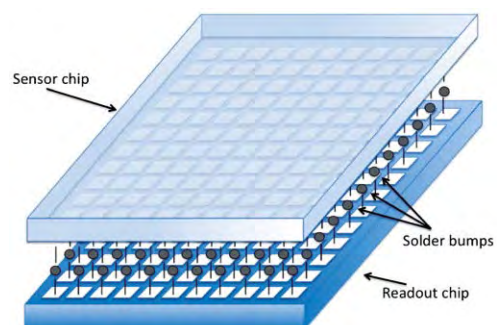
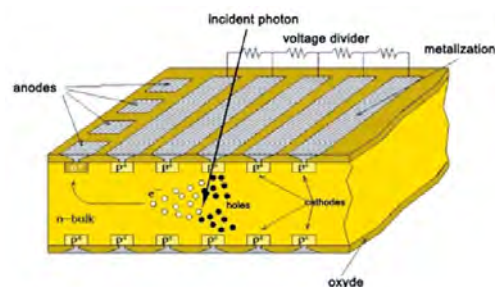
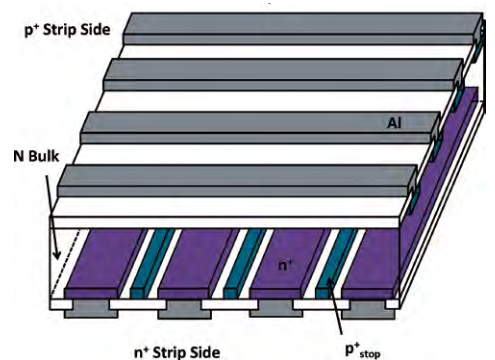
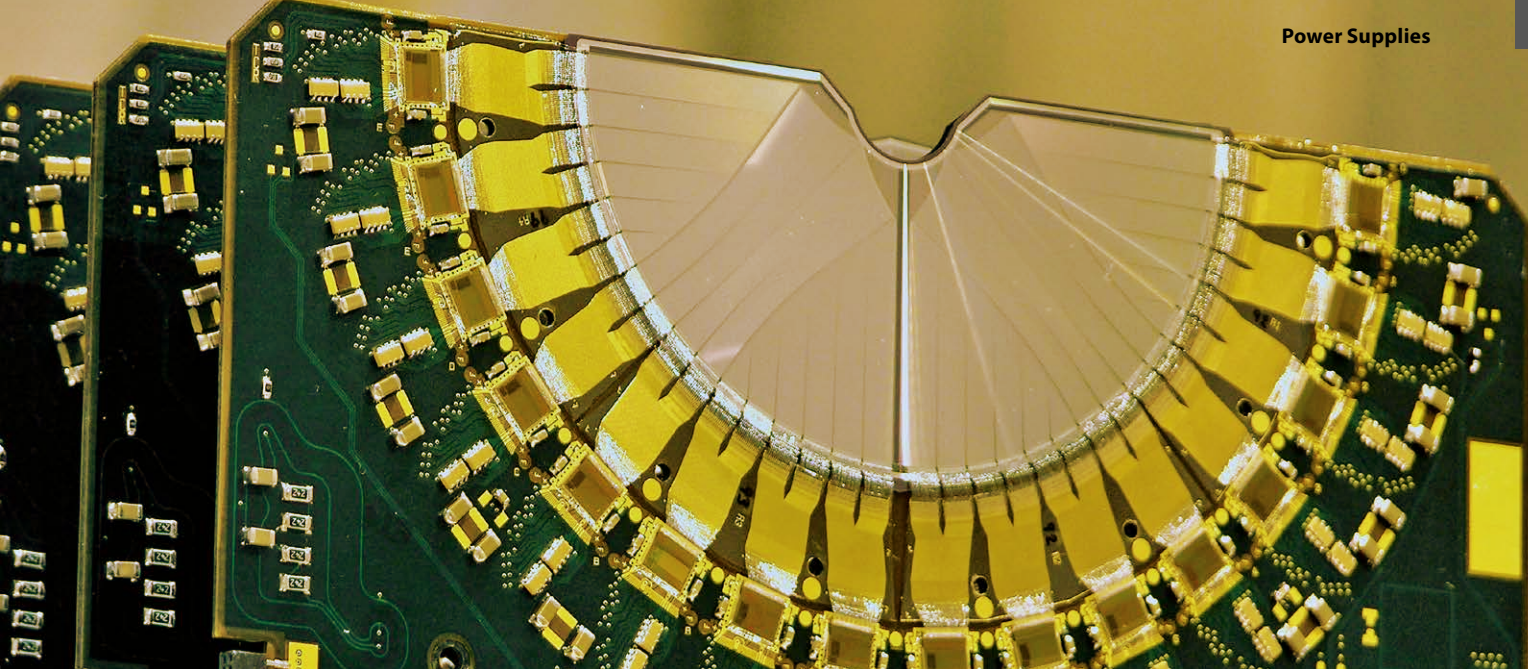

Figure 5: Schematic view of a Silicon Strip (top), Drift (middle) and Pixel (bottom) sensor and working principle



Introduction to High and Low Voltage Power Supplies

influence of an electric field, electrons and holes travel to the electrodes, where they result in a pulse that can be measured in an outer circuit. The holes travel in the opposite direction and can also be measured. Most silicon particle detectors work, in principle, by doping narrow (usually around 100 micrometers wide) strips of silicon to turn them into diodes, which are then reverse biased.

As charged particles pass through these strips, they cause small ionization currents that can be detected and measured. Arranging hundreds or thousands of these detectors around a collision point in a particle accelerator can yield an accurate picture of what paths particles take. Silicon detectors have a much higher resolution in tracking charged particles than older technologies such as cloud chambers or wire chambers. The drawback is that silicon detectors are much more expensive than these older technologies and require sophisticated cooling to reduce leakage currents (noise source).

They also suffer degradation over time from radiation. Three typical configurations of a silicon detector are silicon micro-strip, silicon drift and silicon pixels detectors. All of them frequently operate in high radiation environments and require a bias voltage adjustable on a wide range, typically from 0 to 500 V, with a high precision remote monitoring and controlling system for voltages and currents, in order to avoid breakdowns and guarantee a constant gain over time.

"Semiconductor detector" Wikipedia: The Free Encyclopedia. Wikimedia Foundation, Inc. 22 July 2004. Web. 10 Aug. 2004.

Silicon Detectors Power Supply Requirements	
Typical Voltage (bias)	50 – 500 V
Typical Current (bias)	1 mA
Typical Voltage (electronics)	2 – 5 V
Typical Current (electronics)	40 to 500 mA
Polarity	Positive or Negative

Germanium detectors

Germanium detectors are mostly used for gamma spectroscopy in nuclear physics, as well as x-ray spectroscopy. While silicon detectors cannot be thicker than a few millimeters, germanium can have a depleted, sensitive thickness of centimeters, and therefore can be used as a total absorption

detector for gamma rays up to few MeV.

The major drawback of germanium detectors is that they must be cooled to liquid nitrogen temperatures to produce spectroscopic data. At higher temperatures, the electrons can easily cross the band gap in the crystal and reach the conduction band, where they are free to respond to the electric field, producing too much electrical noise to be useful as a spectrometer. Cooling to liquid nitrogen temperature (77 K) reduces thermal excitations of valence electrons so that only a gamma ray interaction can give an electron the energy necessary to cross the band gap and reach the conduction band.

"Semiconductor detector" Wikipedia: The Free Encyclopedia. Wikimedia Foundation, Inc. 22 July 2004. Web. 10 Aug. 2004.

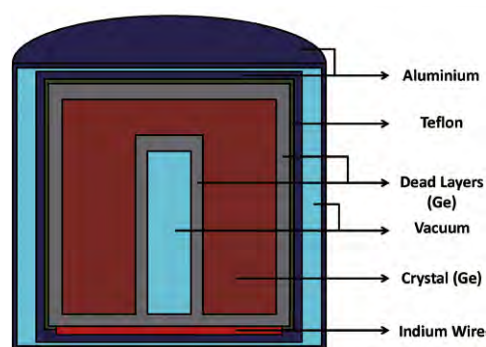
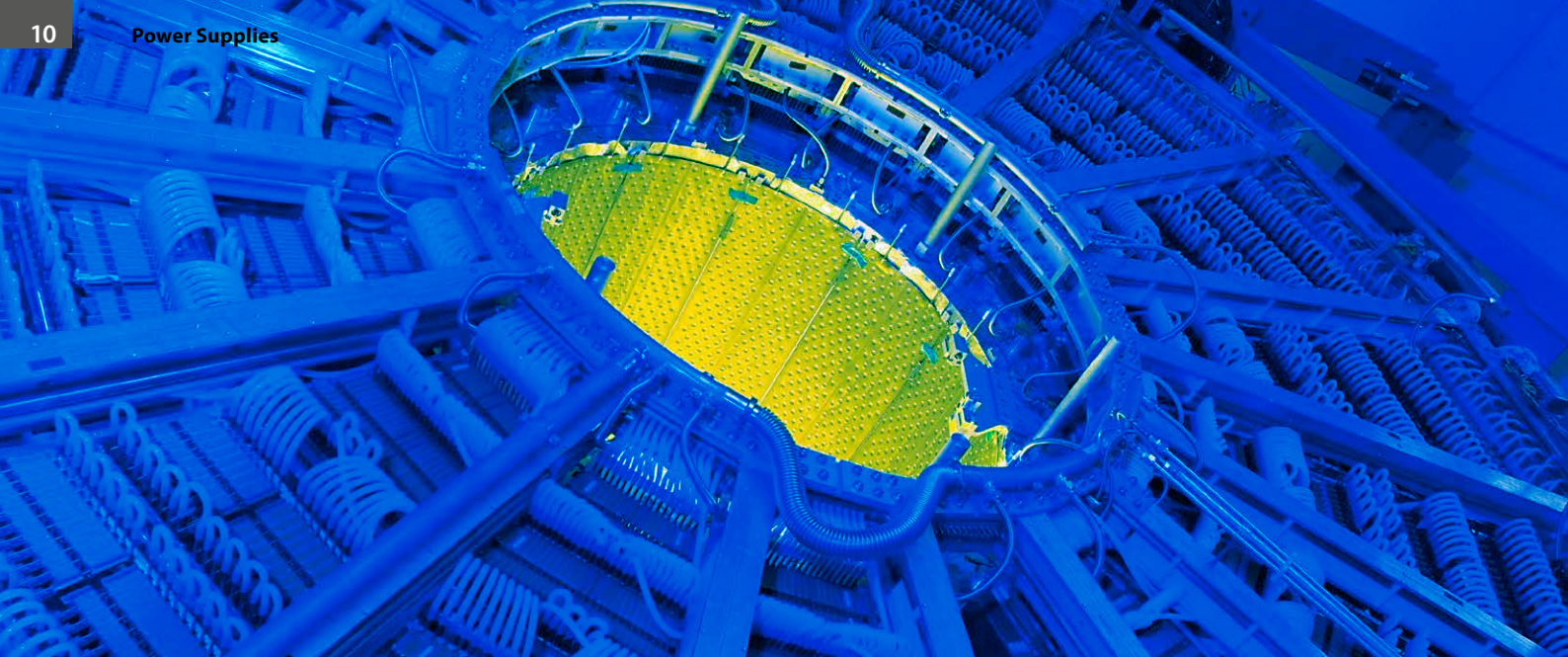

Figure 6: Schematic view of a Germanium detector

Germanium Detectors Power Supply Requirements	
Typical Voltage (bias)	Up to 4500 V
Typical Current (bias)	0.1 – 1 mA
Typical Voltage (electronics)	2 – 5 V
Typical Current (electronics)	40 to 500 mA
Polarity	Positive or Negative



Introduction to High and Low Voltage Power Supplies

Wire Chambers

The Wire Chambers are particle detectors belonging to the family of gaseous detectors. It is composed by a wire or an array of wires kept at high voltage (anode), which run through a chamber with conductive walls held at ground potential (cathode). Alternatively, the wires may be at ground potential and the cathode held at a high negative voltage; the key point is that a uniform electric field draws extra electrons or negative ions to the anode wires with little lateral motion. The chamber is filled with carefully chosen gas, such as an argon/methane mix, such that any ionizing particle that passes through the tube will ionize surrounding gaseous atoms. The resulting ions and electrons are accelerated by the electric field across the chamber, causing a localised cascade of ionization known as a Townsend avalanche.

This allows to count the crossing particles and if chamber is used in the proportional regime to evaluate the particle energy loss. In case of a multi wire proportional chamber by computing pulses from all the wires, the particle trajectory can be found and together with the information about the energy loss, the particle identification can be performed. If one also precisely measures the timing of the current pulses of the wires and takes into account that the ions need some time to drift to the nearest wire, one can infer the distance at which the particle passed the wire.

This greatly increases the accuracy of the path reconstruction and is known as a drift chamber. If two drift chambers are used with the wires of one orthogonal to the wires of the other, both orthogonal to the beam direction, a more precise detection of the position is obtained. If an additional simple detector (like the one used in a veto counter) is used

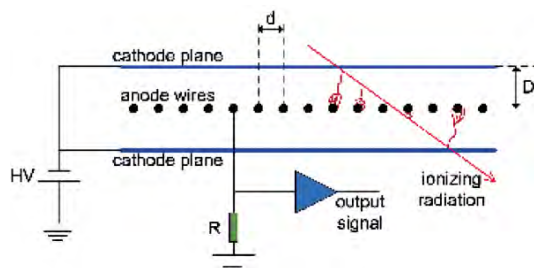

Figure 7: Schematic view of a Wire Chamber working principle

to detect, with poor or null positional resolution, the particle at a fixed distance before or after the wires, a tridimensional reconstruction can be made and the speed of the particle deduced from the difference in time of the passage of the particle in the different part of the detector. This setup gives up the detector called Time Projection Chamber (often written just TPC).

“MultiWire Proportional Chamber” Wikipedia: The Free Encyclopedia. Wikimedia Foundation, Inc. 22 July 2004. Web. 10 Aug. 2004.

Wire Chambers Power Supply Requirements

Typical Voltage	0.5 – 10 kV
Typical Current	less than 1 mA
Polarity	Positive (common) or Negative

MicroMegas detectors

The “Micromegas “ (Micro-MESH Gaseous Structure) detector is a gaseous particle detector coming from the development of wire chamber. The Micromegas works by amplifying the charges that have been created by ionization in the gas volume, divided in two parts by a metallic micro-mesh placed between 25 μm and 150 μm from the readout electrode. The micro-

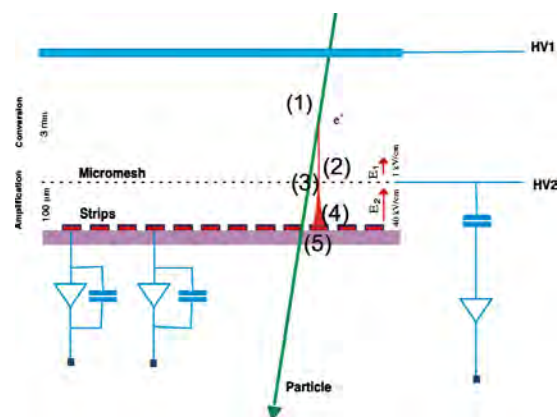

Figure 8: Schematic view of a MicroMegas working principle



Introduction to High and Low Voltage Power Supplies

mesh is the key element since it allows, at the same time a high gain of 10^4 with a fast signal of about 100 ns and a spatial resolution of about 100 μm .

"MicroMegas detector" Wikipedia: The Free Encyclopedia. Wikimedia Foundation, Inc. 22 July 2004. Web. 10 Aug. 2004.

MicroMegas Detectors Power Supply Requirements

Typical Voltage (Mesh)	up to 500 V
Typical Voltage (Drift Electrode)	up to 800 V
Typical Current	nA range
Polarity	Dependent on ground configuration

Resistive Plate Chambers

Resistive Plate Chambers (RPC) are gaseous parallel-plate detectors that combine good spatial resolution with a time resolution comparable to that of scintillators. They are therefore well suited for fast space-time particle tracking applications.

An RPC consists of two parallel plates, made out of phenolic resin (bakelite) with a bulk resistivity of $10^{10} - 10^{11} \Omega\text{cm}$, separated by a gas gap of a few millimeters. The whole structure is made gas tight. The outer surfaces of the resistive material are coated with conductive graphite paint to form the HV and ground electrodes. The read-out is

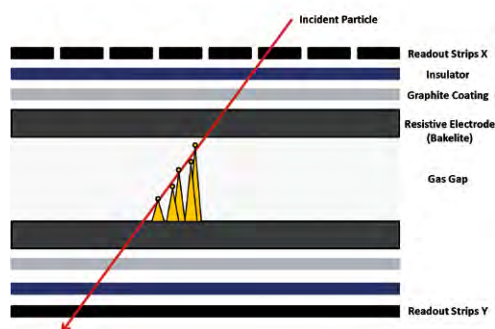

Figure 9: Schematic view of a Resistive Plate Chamber working principle

performed by means of aluminum strips separated from the graphite coating by an insulating PET film. The RPCs can be operated in streamer mode, i.e. the electric field inside the gap is kept intense enough to generate limited discharges localized near the crossing of the ionizing particle. However, the rate capability obtained in such operational conditions is limited ($\sim 100 \text{ Hz/cm}^2$).

A significant improvement is achieved by operating the detector in the so-called avalanche mode; the electric field across the gap (and consequently the gas amplification) is reduced and a robust signal amplification is introduced at the front-end level. The substantial reduction of the charge produced in the gap improves by more than one order of magnitude the rate capability.

"CMS RPC Technical Note" <http://www.nevis.columbia.edu/~chi/rpcl/cms-rpc-tech-note.pdf>

RPC Detectors Power Supply Requirements

Typical Voltage	9 – 12 kV
Typical Current	$1 \mu\text{A/m}^2$
Polarity	Positive or Negative

Gas Electron Multipliers

A Gas Electron Multiplier (GEM) is a type of gaseous ionization detector used in nuclear and particle physics and radiation detection. All gaseous ionization detectors are able to collect the electrons released by ionizing radiation, guiding them to a region with a large electric field, and thereby initiating an electron avalanche. The avalanche is able to produce enough electrons to create a current or charge large enough to be detected by electronics. In most ionization detectors, the large field comes from a thin wire with a positive high-voltage potential; this same thin wire collect the electrons from the avalanche and guides them towards the readout electronics.

GEMs create the large electric field in small holes in a thin polymer sheet; the avalanche occurs inside of these holes. The resulting electrons are ejected from the sheet, and a separate system must be used to collect the electrons and guide them towards the readout. GEMs are one of the class of micropattern gas detectors; this class includes micromegas and other technologies.

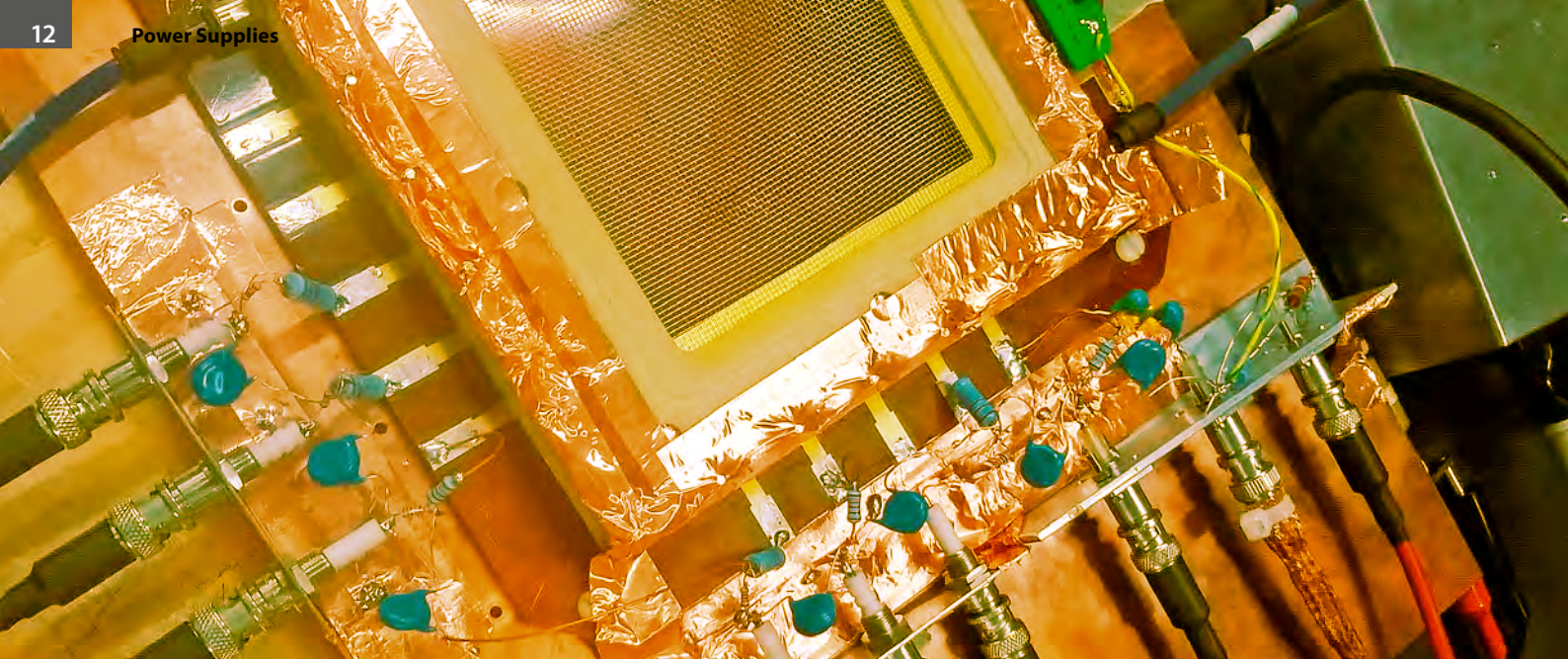

Introduction to High and Low Voltage Power Supplies

Typical GEMs are constructed of 50–70 micrometre thick Kapton foil clad in copper on both sides. A photolithography and acid etching process makes 30–50 micrometer diameter holes through both copper layers; a second etching process extends these holes all the way through the Kapton. The small holes can be made very regular and dimensionally stable. For operation, a voltage of 150–400 V is placed across the two copper layers, making large electric fields in the holes. Under these conditions, in the presence of appropriate gases, a single electron entering any hole will create an avalanche containing 100–1000 electrons; this is the “gain” of the GEM. Since the electrons exit the back of the GEM, a second GEM placed after the first one will provide an additional stage of amplification. Many experiments use double- or triple-GEM stacks to achieve gains of one million or more.

“Gas electron multiplier” Wikipedia: *The Free Encyclopedia. Wikimedia Foundation, Inc. 22 July 2004. Web. 10 Aug. 2004.*

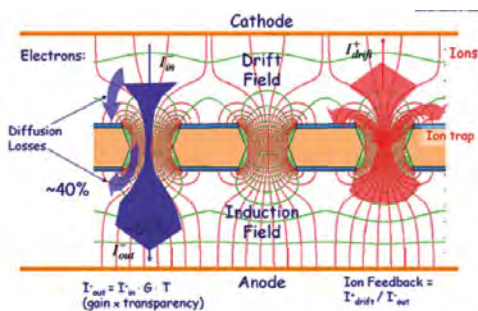

Figure 10: Schematic view of a GEM working principle

Image Credits pp.10-20

1. p.10: CMS WOW images used for the tent exhibition at Point 5 - © Michael Hoch - CMS Management:Communications Group
2. p.11: Views of the final closure of the End Cap Toroid Magnet side C in the ATLAS cavern, 27 May 2009. © 2009-2016 CERN
3. p.12 – Header: The ALICE detector. © 2009-2016 CERN
4. p.13 – Header: View of the LHCb cavern on 20 May 2009. © 2009-2016 CERN
5. p.14 - Header: Photomultiplier, Dumont 6363. Draufsicht. Photographie erfolgte durch das stark getönte Eintrittsfenster des Geräts. Photo: © Jörgens.Mi/Wikipedia, Licence: CC-BY-SA 3.0 (URL: <http://creativecommons.org/licenses/by/3.0/legalcode>), Source: Wikimedia Commons (URL: https://commons.wikimedia.org/wiki/File:Photomultiplier_6363_04.jpg)
6. p.14 – Fig.1: Schematic of a photomultiplier coupled to a scintillator, configured to show, correctly, the detection of gamma rays. Author: © Qwerty123uiop/Wikipedia, Licence: CC-BY-SA 3.0 (URL: <http://creativecommons.org/licenses/by/3.0/legalcode>), Source: Wikimedia Commons (URL <https://commons.wikimedia.org/wiki/File:PhotoMultiplierTubeAndScintillator.jpg>)
7. p.14 – Fig.2: © CAEN spa.
8. p.15 – Header: Avalanche photodiode. Photo: © Radovan Blažek/Wikipedia, Licence: CC-BY-SA 3.0 (URL: <http://creativecommons.org/licenses/by/3.0/legalcode>), Source: Wikimedia Commons (URL https://commons.wikimedia.org/wiki/File:Avalanche_photodiode.JPG)
9. p.15 – Fig.3: © CAEN spa.
10. p.16 – Fig.4: © 2011 Barbarino G, de Asmundis R, De Rosa G, Mollo CM, Russo S, Vivolo D. Published in “Silicon Photo Multipliers Detectors Operating in Geiger Regime: an Unlimited Device for Future Applications”, Photodiodes - World Activities in 2011, under CC BY-NC-SA 3.0 license.
11. p.16 – Header: Assembly of the ALICE Silicon Strip Detector © 2006-2016 CERN
12. p.16 – Fig.5a: © CAEN spa.
13. p.16 – Fig.5b: Courtesy of INFN-Trieste (Italy).
14. p.16 – Fig.5c: Picture from “25 years of Microelectronics at CERN: from LAA to the LHC”, Newsletter of the PH Department. (<http://ph-news.web.cern.ch/content/25-years-microelectronics-cern-laa-lhc>) © CERN
15. p.17 – Header: Three modules of the LHCb Vertex Locator in the H8 test beam in the North Area © 2008-2016 CERN
16. p.17 – Fig.6: © CAEN spa.
17. p.18 – Header: Artistic pictures of the ALICE Time Projection Chamber © 2006-2016 CERN
18. p.18 – Fig.7: Simulation Studies of Charge Transport on Resistive Structures in Gaseous Ionization Detectors - Budanur, Nazmi Burak arXiv:1207.4585 [physics.comp-ph] CERN-THESIS-2012-330
19. p.18 – Fig.8: Principle of the Micromegas detector. Author: © MicroMesh/Wikipedia, Licence: CC-BY-SA 3.0 (URL: <http://creativecommons.org/licenses/by/3.0/legalcode>), Source: Wikimedia Commons (URL <https://commons.wikimedia.org/wiki/File:PhotoMultiplierTubeAndScintillator.jpg>)
20. p.19 – Header: Assembly of the CMS HF (hadron forward) calorimeter, April 2003 to June 2005. © 2008 CERN, for the benefit of the CMS Collaboration
21. p.19 – Fig.9: © CAEN spa.
22. p.20 – Header: © CAEN spa.
23. p.20 – Fig.10: Courtesy of the GEMINI Project (<https://web2.infn.it/GEMINI/>) © GEMINI All rights reserved

GEM Detectors Power Supply Requirements

Typical Voltage	300 – 500 V (GEM foils) / 500 - 700 V (Transfer gaps)
Typical Current	1 - 10 mA (GEM foils) / few μ A (Transfer gaps)
Polarity	Positive or Negative



Introduction to High and Low Voltage Power Supplies

We believe that a perfect blend of tradition and innovation is the footprint of our DNA. In terms of tradition, CAEN power supplies have born and grown in the years side by side with research institutions, being part of their activities since the very beginning. Thanks to our synergies with researchers and our internal expertise, our power supplies have become a de-facto standard in most Physics laboratories all around the world. Moreover, we have been the first to introduce the concept of high density multichannel power supplies, which are mandatory for large arrays of detectors.

As for innovation, we have continuously introduced new features in our power supplies which have set further standards of operations. During LHC setup phase, we have been the first to design power supplies able to withstand the harsh conditions of experimental halls such as radiation and magnetic field.

Our latest designs include sophisticated touch-screen control, Wi-Fi connections and single dashboard control software, in line with the most advanced consumer electronics.

The demonstration of this successful long-standing blend of tradition and innovation is the "CMS Crystal Award 2009" that CAEN received for the development and production of the supply system for the CMS tracker. CAEN offers a wide selection of power supplies in different form factors and standards.

For smaller set ups NIM and VME modular products as well as Desktop and Rack power supplies are the ideal fit. For larger setups, where a high number of High Voltages and Low Voltages is required, the Universal Multichannel Systems and boards (up to 48 channels/board) are the most recommended.

Universal Multichannel Systems

Universal Multichannel Power Supply Systems are entirely developed by CAEN based on mainframes housing dedicated boards and they show features which can be useful in the most challenging environments. Typically, when there is the need of high density of channels (up to 768 channels per mainframe) and mixing high voltage and low voltage power supply boards in the same crate, the CAEN systems are the best choice to keep your power supply system compact. Another critical factor that brings the attention to this solution is the advanced control that can be established between the user and the system. It's based on a OPC Server/EPICS software which can be easily integrated in the user's Supervisory Control And Data Acquisition (SCADA) and

Detector Control System (DCS), allowing the setting and monitoring of all the parameters of interest on the mainframe through Ethernet connection. When all or some of these requests are met, then the Universal Power Supply System is a cost effective solution.

Modularity, flexibility and reliability are the key-points of its design, enabling this module to meet the requirements needed in a wide range of experimental conditions, which range from those of LHC experiments, where the features of this model find prior application, to those of other less challenging, but still demanding, High Energy Physics experiments.



NIM High Voltage Power Supplies

The NIM (Nuclear Instrumentation Module) standard was first defined by the U.S. Atomic Energy Commission in 1968-1969. The idea was to realize a flexible and simple system based on interchangeable modular electronics for experimental Particle and Nuclear Physics. The goal was completely accomplished, since still nowadays NIM Modules are in widespread use all around the world in experimental physics, either big projects or small laboratories.

NIM High Voltage Power Supplies are the best choice for small experiments in which a really low noise feature is expected. CAEN offer a new generation of NIM Power Supplies that can operate in daisy-chain network and can be locally or remotely controlled through a dedicated software. In this way it's possible to control up to 128 Channels and make of this setup a complete system.

The NIM Line includes also the NDT Power Supplies, which are hosted in a NIM module and can be plugged in NIM crates for power but have also the chance of desktop operation thanks to a mains power supply cord.





Introduction to High and Low Voltage Power Supplies

VME High Voltage Power Supplies

The VME bus (VERSA Module Eurocard) architecture was born in 1981 as a combination of VERSA bus electrical specification and EUROCARD form factor. Its development was first due to industrial application, where its durability and flexibility solved some problems involved in the use of first personal computers. These qualities made it ideal for many applications like military, medical, telecommunication and high energy physics.



The VME boards are a fingerprint of CAEN production, a deep knowledge achieved in 20 years of experience with the world's largest physics experiments.

Initially born for data acquisition and front end applications, CAEN has recently introduced a new series of VME programmable HV boards, able to fit the same standard crate of DAQ systems. Thanks to the innovative GECO2020 Control Software and the multimaster capability of CAEN VME Bridges, it is possible to control independently the VME DAQ and the VME Power Supply Units.

Desktop and Rack High Voltage Power Supplies

The first standard power supplies for physics experiments have been hosted in NIM modules. This is convenient for laboratories and small setups, but sometimes detector development is carried out on test benches or desks. For this reason, CAEN has developed a new line of Desktop and Rack Power Supplies, able to cover most voltage and current ranges used in the majority of detectors.

Remote control is performed via USB or Ethernet. The Desktop Power Supplies are compact and self-contained without the need of hosting crates of any kind while the Rack Power Supplies allows an easy housing in a standard 19" rack unit.



PCB Power Supplies

In the recent years, answering to a growing market demand, CAEN started also developing new high voltage power supply families in a PCB form factor. In the astroparticle research field for instance, in which large area experiment composed by detectors spread over a very large area are involved, the traditional multichannel approach become unfeasible and the necessity of a distributed solution become unavoidable.

The new CAEN PCB DC/DC converter families provides a solution to these kind of needs without giving up to high performances and to the reliability of a remote control (analog or digital).



High Power Low Voltage System

A typical requirement which is often underestimated is the need of high power, low voltage channels. This may be needed for special front-end electronics, often placed in the detector cavern, which need to be supplied by an external powerful source, with high reliability and remote wire sensing, to reach the exact low voltage supply even with tens of metres of cables.

All the above can be fulfilled by the SY8800 Universal Multichannel Low Voltage Power Supply System, which provides the usual flexibility of its modular design with the highest standards of CAEN quality.



Power Supply Control Software

All CAEN power supplies share the same basic design concepts. In order to ease the use of these boards, whichever the standard or form factor, CAEN has designed a set of Control Software tools. Ranging from OPC Servers, to LabVIEW™ Instrument Drivers, to a complete and powerful standalone tool with advanced Graphical User Interface, such as GECO2020, the users will be able to find the right CAEN Control Software for their own applications.



CAEN longstanding expertise in the design of power supplies finds its synthesis in the development of power supply systems. Our new product family conciliates the solidity of the operation with innovative connectivity and handy graphical interface.

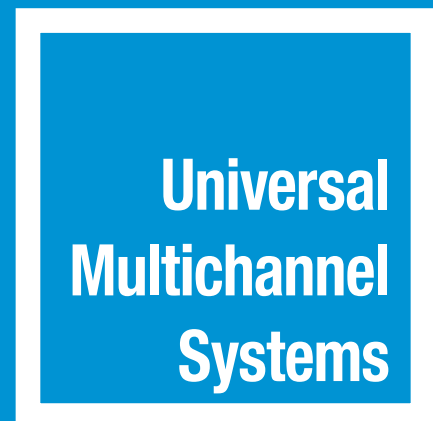

Mainframes
High Voltage and Low Voltage Multichannel Boards

Mainframes

SY4527 and SY5527 - Universal Multichannel Systems

Mechanics

The completely redesigned mechanics is available in two robust versions: a large system able to house up to 16 boards (SY4527) or a more compact one able to house up to 6 boards (SY5527) to fit the needs of both big experiments and smaller setups.



Modularity

The new systems are designed to be configured with the maximum flexibility. The user can compose his preferred configuration according to his needs. This modularity also further improves the system maintenance thanks to its easy-to-replace modular CPU and Power Supplies.



CPU

The control section is based on a completely new CPU module. It is available in three different versions: BASIC, ADVANCED and FULL.



Control Software

A completely New Control Software with graphical interface allows the user to manage, set and monitor all the parameters of the system, the boards installed and the channels. The standard software can be enhanced with an advanced set of features like, LOGGING and SCRIPTING.

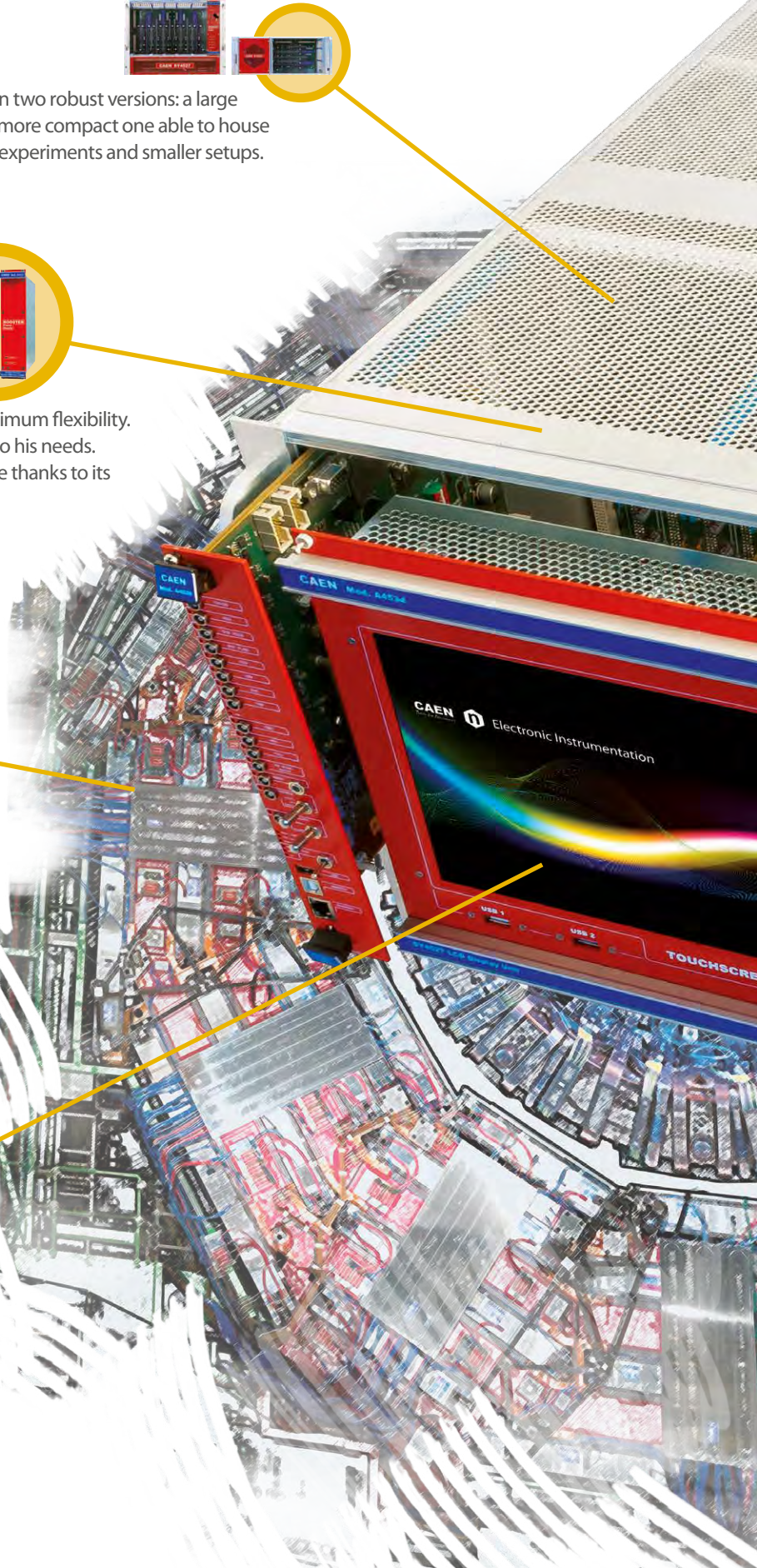

Four simple steps to build your *Mainframe!*

1 SELECT A CHASSIS...



2 SELECT A CPU...



3 ADD MORE POWER...



4 ADD THE ACCESSORIES...



... and now pick the boards best fitting your application from the wide selection of our Catalog!



Control Interface
The system can be controlled either **LOCALLY**, via the new Touchscreen LCD, or **REMOTELY** via Gigabit Ethernet or Wi-Fi connection. Web based control is also provided.

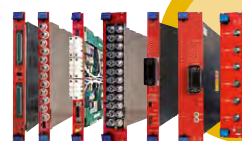

Compatibility

A new backplane fully compatible with all the boards developed for the previous SY1527/SY2527 (HV and LV power supplies, branch controllers, ...) supports now high speed communication.



Power Supply Units

Three different Power Supply Units allow the user to expand the basic 600 W power supply up to 4200 W (1800 W per SY5527).



Mainframes



Software Tools available free!

Improved mechanics, modularity and compatibility at your service

SYx527 and SYx527LC

Modularity, Compatibility, Connectivity, Usability and Solidity are the keywords of the SYx527 system design. The system has been specifically designed to power all detector technologies found in modern Physics Experiments, such as e.g. photomultipliers, wire chambers, streamers tubes, silicon detectors.

The systems are modular, flexible and match not only the requirements of major experiments with large number of channels but also the practical needs of test laboratories, where simple manual operations on a limited number of channels are often desired.

The line consists of four different mainframe versions:

- The **SY4527** is a 19" wide / 8U high mainframe and can house up to 16 boards, to which it can provide a power up to 4.2 kW.
- The compact version **SY5527** is 19" wide / 4U high mainframe and can house up to 6 boards, to which it can provide a power up to 1.8 kW.
- The **SY4527LC** is a 19" wide / 8U high mainframe and can house up to 10 boards, to which it can provide a power of 600 W. This version is nearly 20 cm shorter than the standard version.
- The **SY5527LC** is a 19" wide / 4U high mainframe and can house up to 4 boards, to which it can provide a power of 400 W. This version is more than 20 cm shorter than the standard version.

SYx527

Features

- Power supply section made of modular and easy-to-replace units
- CPU module available in three versions (BASIC, ADVANCED and FULL) to best fit the application requirements. The CPU is also easily replaceable by the user.
- REMOTE (via Gigabit Ethernet - SNMP compatible - or optionally via Wi-Fi) and LOCAL (via an optional Color Touchscreen LCD) control available
- Backplane fully-compatible with all the boards developed for the previous SY1527/SY2527: power supplies, distributors and branch controllers.
- Both the new mainframes available in the PREMIUM edition including all the options: Touchscreen Display (5.7" or 10.4" colour touchscreen LCD), Wi-Fi connectivity and the advanced software capability.
- Advanced Trip handling
- Hardware current protection
- Reset and Interlock control
- Modular and expandable power supply
- Easy firmware upgrading
- Fast, accurate setting and monitoring of channel parameters
- New software developed with graphical user interface. Mainframe operation manageable with the installed touchscreen (optional) and with any external PC/Laptop. User-friendly Java application automatically installed on user machine when connected to the mainframe with any web browser. New software GECO2020 allows to control at the same time multiple mainframes together with power supply boards in any VME and NIM crates.
- Connection via Gigabit Ethernet or Wi-Fi.
- OPC Server to ease integration in Detector Control System
- Integrated EPICS IOC
- Secure access to the system via Intranet

Overview

The SYx527 system is the fully equipped experiment version of a new line of power supply systems which represent CAEN's latest proposal in the matter of High Voltage and Low Voltage Power supplying. This system outlines a completely new approach to power generation and distribution by allowing the housing, in the same mainframe, of a wide range of boards with different functions, such as High/Low Voltage boards, generic I/O boards (temperature, pressure monitors, etc.) and branch controllers, where the latter are used to control other remote generators. Modularity, flexibility and reliability are the keypoints of its design, enabling this module to meet the requirements needed in a wide range of experimental conditions. The mainframe is housed in a 19"-wide, 4 or 8U-high euro-mechanics rack and hosts four main sections:

- the **Board Section**, with 16 (6 for SY5527) slots to house boards, distributors and branch controllers;
- the **Fan Tray Section**, housing 6 (3 for SY5527) fans arranged on two rows, with programmable rotation speed regulation;
- the **Power Supply Units Section**, which consists of the primary power supply and up to 3 (1 for SY5527) optional power supply units;
- the **CPU and Front Panel Section** which includes all interface facilities.

The CPU controller is available in 3 different versions: BASIC, ADVANCED and FULL.

- The **BASIC** version provides all the communication interfaces, the RESET control, the INTERLOCK control and status LEDs.
- The **ADVANCED** version also provides the beam handshake management connectors (CH-ON, GEN, VSEL, ISEL).
- The **FULL** version provides the complete set of panel connectors, the ENABLE control section, and the fan speed control.

The Power Supply Unit (PSU) is available in 3 different versions:

PRIMARY, OPTIONAL SINGLE, OPTIONAL DOUBLE.

- The **Primary PSU** is the SYx527 Primary Power Supply block. It includes the SERVICE and the 600 W PSU for boards in a single slot module. Each SY4527/SY5527 System includes one A4531 Primary Power Supply
- The **Optional Single PSU** adds 600 W of power in a single slot module
- The **Optional Double PSU** adds 1200 W of power in a single slot module

Please note: the CAEN power supply boards require an amount of power to keep the motherboard control electronics on. When configuring the SYx527 with Primary and Optional PSUs our customers should consider also that power consumption. This could be a critical issue when several power supply boards are installed in the SYx527 systems. In similar cases, we suggest our customers to contact CAEN sales representatives and technical support for more information.

The Software User Interface features the usual friendliness of the previous CAEN systems which now also can optionally include a 5.7" (10.4" for SY4527) color touchscreen LCD.

Modularity has been one of the leading criteria in the design and development of the system: both the Power Supply Units Section and the Board Section are completely modular. The Power Supply Units Section allows different configurations with up to 2 or 4 units per mainframe (up to 1800 W for SY5527 and 4200 W for SY4527),

while the Board Section can house up to 16 (6 for SY5527) boards able to perform different functions. The complete line of power supply boards that has been specially developed for SY1527/SY2527 are fully compatible with the new mainframes.

The minimum working system configuration consists of the primary power supply unit, one CPU controller and one board. The system allows also to deal with power supply solutions composed by "branch controllers" (housed in the system mainframe) and on-detector "remote boards" (manufactured in order to be magnetic field and radiation tolerant). A sophisticated trip handling via software allows to control and correlate trip conditions on the channels of the crate. Live insertion and extraction of the boards, which reduces the down time of the global system and eases access to the computing core and peripherals of the system, complete the system flexibility. Easy interfacing is another key-point of the SYx527 system. The Gigabit Ethernet interface (and the optional Wi-Fi interface) allows both an easy web access and the connection via OPC Server, EPICS or LabVIEW to a SCADA control system. Enhanced software programming features a unified command set independent from the interface used to communicate with the system. The Power Supply Section and Board Section can be externally synchronized via front panel connectors. Handy maintenance and upgrading, which constitute a major issue in the reliability of a system, are further guaranteed by the possibility of accessing and servicing the system via network facilities.

Ordering Options - SY4527

Code	Description
WSY4527BSCXA	SY4527 - Universal Multichannel Power Supply System - BASIC 600W
WSY4527ADVXA	SY4527 - Universal Multichannel Power Supply System - ADVANCED 600W
WSY4527FLLXA	SY4527 - Universal Multichannel Power Supply System - FULL 600W
WSY4527PREXA	SY4527 Premium - Includes SY4527 FULL, A4534, A4535, SW4536

Ordering Options - SY5527

Code	Description
WSY5527BSCXA	SY5527 - Universal Multichannel Power Supply System - BASIC 600W
WSY5527ADVXA	SY5527 - Universal Multichannel Power Supply System - ADVANCED 600W
WSY5527FLLXA	SY5527 - Universal Multichannel Power Supply System - FULL 600W
WSY5527PREXA	SY5527 Premium - Includes SY5527 FULL, A5534, A4535, SW4536

Ordering Options - SYx527 Accessories

Code	Description
WA4534XAAAAA	A4534 - SY4527 10.4" LCD Touchscreen color Display Unit
WA4537XAAAAA	A4537 - SY4527 5.7" LCD Touchscreen color Display Unit
WA5534XAAAAA	A5534 - SY5527 5.7" LCD Touchscreen color Display Unit
WA4535XAAAAA	A4535 - SY4527/SY5527 Wi-Fi Dongle for Wireless connectivity
WSW4536XAAAAA	SW4536 - SY4527/SY5527 Control software functionality enhancement activation code
WA4528ADVXAA	A4528 - SY4527/SY5527 CPU Module ADVANCED
WA4528BSCXAA	A4528 - SY4527/SY5527 CPU Module BASIC
WA4528FLLXAA	A4528 - SY4527/SY5527 CPU Module FULL
WA4531XAAAAA	A4531 - SY4527/SY5527 Primary Power Supply 600W
WA4532S600XA	A4532 - SY4527/SY5527 Optional Single Power Supply Unit 600W
WA4533D1200X	A4533 - SY4527/SY5527 Optional Double Power Supply Unit 1200W

SYx527LC

Features

- Houses up to 10 boards (4 boards for the SY5527LC)
- More compact and handy
- ~ 20 cm shorter than the standard versions
- Ad-hoc boards and peripheral systems
- Fully compatible with boards for normal systems

Overview

The SYx527LC systems are a new line of power supply systems which represent a cost effective proposal in the matter of High Voltage and Low Voltage power supplying. The complete line of power supply boards and distributors developed for SY5527 and SY4527 are fully compatible with these mainframes. The front panel houses the BASIC version of the A4528 CPU Module and the mainframe power supply unit. The SY4527LC and SY5527LC will be powered with 600 and 400 W respectively.

Ordering Options - SYx527LC

Code	Description
WSY4527LCXAA	SY4527LC - 10 Slot Low Cost Universal Multichannel Power Supply System
WSY5527LCXAA	SY5527LC - 4 Slot Low Cost Universal Multichannel Power Supply System
WSW4536XAAAA	SW4536 - SY4527/SY5527 Control software functionality enhancement activation code

Gallery



SY5527 Full front view



SY4527 Full front view



SY4527LC with boards



SY5527LC with boards



SY4527 rear view with boards



SY4527 Full with LDC monitor front view



SY5527 Full with LDC monitor front view

CPU Modules and Power Supply Units

CPU Modules

A4528x CPU Modules

3 different CPU modules for SYx527: Basic, Advanced, Full.

Basic version

- Communication interfaces
- RESET control
- INTERLOCK control
- Status LEDs



Mod. 4528BSC

Advanced version

- Communication interfaces
- RESET control
- INTERLOCK control
- Status LEDs
- Beam handshake management connectors (CH-ON, GEN, VSEL, ISEL)



Mod. 4528ADV

Full version

- Communication interfaces
- RESET control
- INTERLOCK control
- Status LEDs
- Beam handshake management connectors (CH-ON, GEN, VSEL, ISEL)
- CHK PASS, RST FLAG, OVV, UNV, OVC, TRIP, KILL and HV SYNC connectors
- ENABLE control section
- Front panel Fan speed control



Mod. 4528FLL

Power Supply Units

A453x Power Supply Units

3 different Power Supplies for SYx527: Primary, Optional Single, Optional Double.

Primary PSU - 600 W

Primary Power Supply: it is the basic block and it includes the SERVICE PSU and the 600 W PSU for boards in a single slot module. Each System includes one Primary Power Supply 600 W.



Mod. A4531

Optional Single PSU - 600 W

Optional Single Power Supply Unit: this PSU adds 600 W of power in a single slot module. This is an optional item to be ordered separately.



Mod. A4532

Optional Double PSU - 1200 W

Optional Double Power Supply Unit: this PSU adds 1200 W of power in a single slot module. This is an optional item to be ordered separately.



Mod. A4533

Note: In SY4527 the max number of PSU which can be installed is 4 (1 Primary and 3 Optional). In case the SY4527 is equipped with LCD display the max number is 2 (1 Primary and 1 Optional). In SY5527 the max number of PSU which can be installed is 2 (1 Primary and 1 Optional).

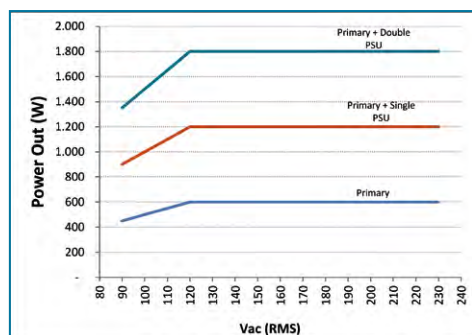

SY5527

The following charts show the available output power depending on installed Power Supply Units and input power voltage line for both Mainframes.
(Maximum Output Power vs. Power Supply Units and power voltage line)

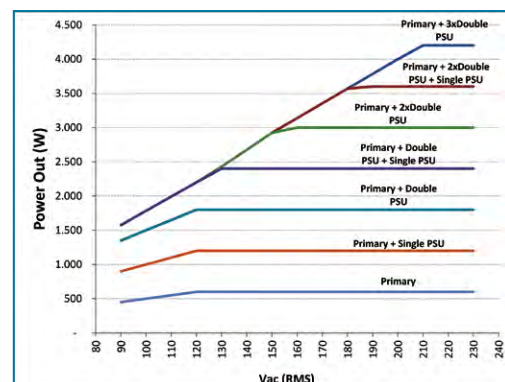

SY4527

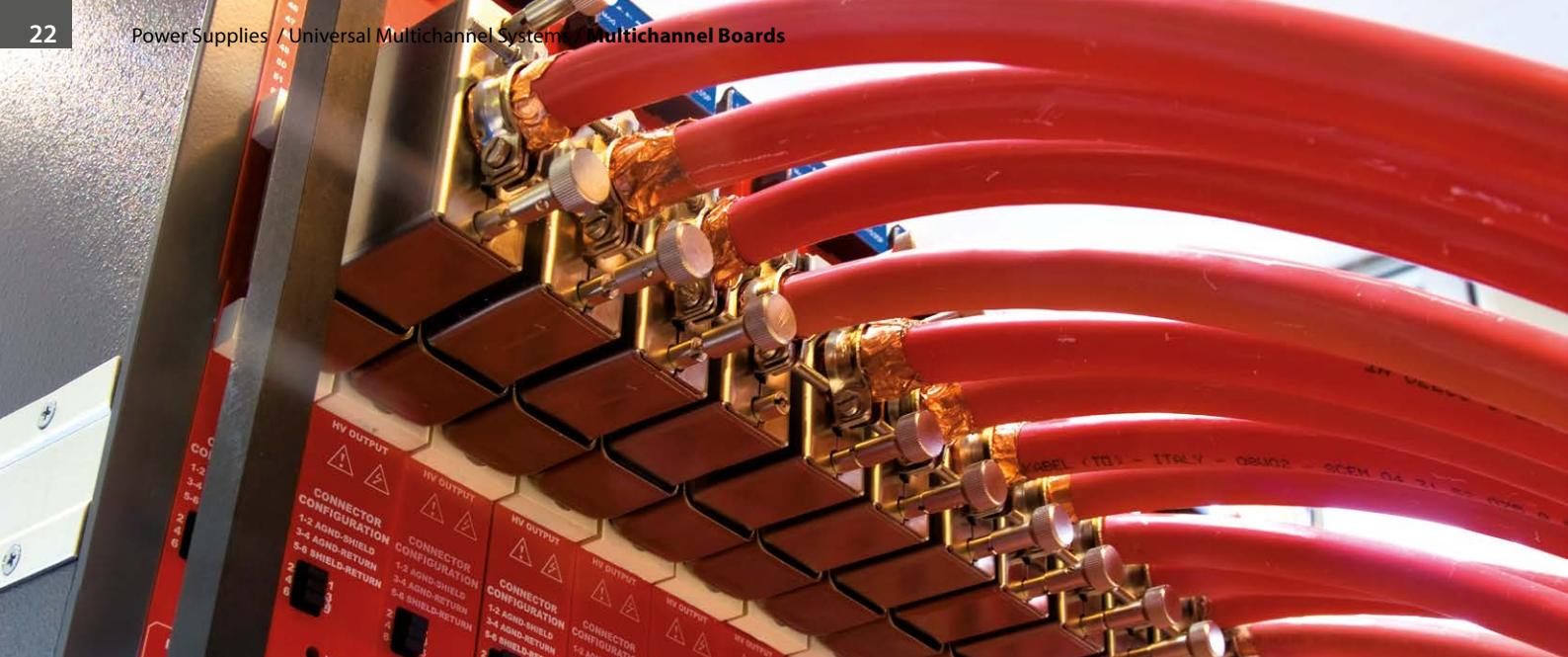

High Voltage and Low Voltage Multichannel Boards

CAEN provides power supply boards featuring full **independent channels**. Each channel mounts its own DC-DC converter, voltage and maximum supplied current can be adjusted independently over the full dynamic range.

The power supplies that we realize are suited also for applications where the detector power consumption is demanding: e.g. systems of multiple phototubes which require currents of few mA per channel. In other cases the current consumption could be smaller than 1 mA and the measurement of the current consumption could be an important parameter. CAEN provides power supplies with current resolution down to few pA.

Moreover, for customers which need both accurate current monitoring and high power output we provide **Dual Range** power supplies: the user can switch between an high current regime and a low one, with the possibility to improve the absolute precision of the current monitor.

CAEN goal is the customer satisfaction and its R&D collaborates with researchers to develop products for special requests. Our company delivers high profile power supplies to match the requirements of new detector technologies and to guarantee long term stability of the specifications. CAEN is proud to have provided the devices and the technical support which allowed experimental collaborations of the last decades to develop their apparatus and achieve their scientific goals. Several major particle physics experiments, and more recently the CMS and ALICE collaborations, entrusted CAEN with the realization of the power supplies for their Silicon trackers. We provided for instance our low voltage power supplies with Remote Sensing Lines to control the voltage drop along the power lines and we also developed power supply units able to operate in extreme conditions of radiation and magnetic fields.

Highlights

- Fully independent channels
- Set current and voltage, remotely and locally
- High current resolution, or high output power or dual range
- Live insertion
- Multiple choice of connector types and adapters: SHV, CPE, DB, Radiall
- Multiple choice of channel grounding
- Remote and programmable interlocks
- Overvoltage and undervoltage programmable protections
- Overcurrent programmable protection and constant current mode

Single Channel Behaviour

Each channel feature a set of programmable parameters that allows the user a full control: two voltage values (V0SET, V1SET), two current limit values (I0SET, I1SET) and the maximum rate of change of the voltage (V/s). The latter owns two distinct values are available, Ramp-Up and Ramp-Down. Any command to change the voltage will result in a linear voltage increase or decrease with time, the rates being determined by the Ramp-Up or Ramp-Down parameters, respectively. The boards features also programmable (ISET) or fixed (IMAX) current hardware protections and their value represent a software-controlled hardware limitation on the channels' currents. The channel cannot draw a current higher than its programmed limit. If a channel tries to draw a current larger than the programmed limit, it is flagged to be in OVERCURRENT. The System detects this state as a fault and reacts according to the setting of the TRIP parameter, namely:

1 TRIP = infinite (constant CURRENT mode)

If the board has programmable or fixed current hardware protections, the output voltage is varied to keep the current below the programmed limit. The channel behaves like a current generator.

2. TRIP = finite value (TRIP mode)

In this case, the channel behaves as in the constant current mode for a time equal to the finite value set as TRIP parameter, and then

it is switched off according to the selected Power-Down option (Kill/Ramp-Down). If the Kill option is selected, the channel will be switched off immediately. If the Ramp-Down option is selected the voltage will drop to zero at a rate determined by the value of the Ramp-Down parameter programmed for that channel.

Other indicators are foreseen to signal the channel status, such as OVERVOLTAGE, UNDERVOLTAGE and CHANNEL ON.

Power Supply Grounding

CAEN Power Supply units can be distinguished according to their connection to electrical ground. We provide three main boards architectures:

- **Common Ground**
- **Common Floating Return**
- **Individual Floating Channel**

The **Common Ground** configuration is somehow the simplest.

Power supplies of this kind have the channel voltage reference hardwired to the chassis/crate ground.

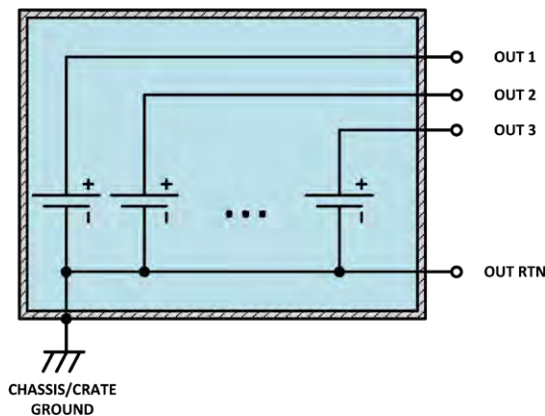

Figure 1: Common Ground Board

The **Common Floating Return** boards have channels sharing one common ground, which is insulated from the chassis/crate ground. This feature may help to minimize problems of ground-loops. The level of insulation from the channel return to chassis/crate ground may vary between different typologies of boards.

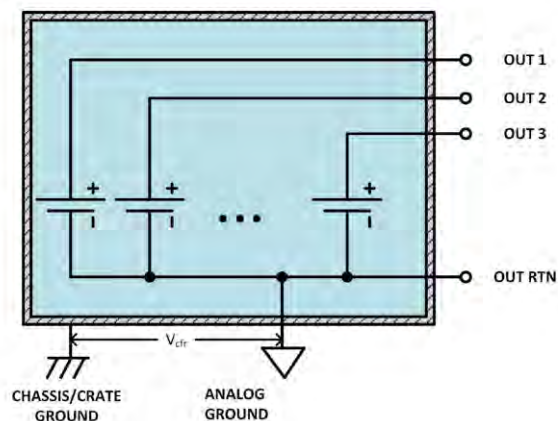

Figure 2: Common Floating Return Board

Generally the common floating return is insulated from chassis /crate

ground up to few tens of volts.

The **Individual Floating Channel** boards have independent channel returns insulated from chassis/crate ground from few tens of volts up to 5 kV.

In this configuration each channel can be connected to a different ground. If the maximum floating voltage is higher than the maximum channel voltage the channel is defined as FULL FLOATING.

A FULL FLOATING channel behave exactly like a battery; by grounding the + terminal it's possible to get a negative voltage and by grounding the - terminal it's possible to get a positive voltage (and it is also possible to mix positive and negative polarity outputs).

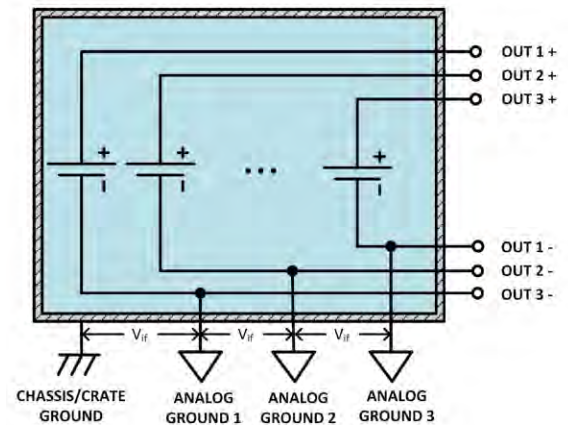

Figure 3: Individual Floating Channel Board

Safety Features

Different safety features were designed for our power supplies. Some of them are general, some other are model-dependent. A full list of the solution implemented follows:

- **Channels can be enabled or disabled** through the Global Interlock logic.
- **Remote Enable/Disable:** front panel independent contacts available for all channels.
- **Common Interlock** logic for channels enable/disable and individual input signal for channel Kill function (only Desktop and NIM modules)
- A **global enable/disable connector** allows to disable the channels and it is also possible, via front panel logic signals, to enable individually each channel (only Low Voltage modules)
- **Overvoltage and Undervoltage warning** allows to disable the channels and it is also possible, via front panel logic signals, to enable individually each channel (only Low Voltage modules).
- **Hardware VMAX and IMAX:** maximum output voltage and maximum output current value can be fixed, via front panel potentiometer, at the same common value for all the board channels. IMAX and VMAX values can be read out via software.
- **Software VMAX and IMAX:** maximum output voltage and maximum output current value can be fixed via control software at channel by channel specific value
- **Overcurrent detection:** when a channel attempts to exceed the programmed (ISET) or fixed (IMAX) current limit, it signaled to be in "overcurrent" and enter in a TRIP status: the channel is switched off after a programmable TRIP time.
- **Safety Board Interlock:** this protection disables the HV generation when the HV outputs are not connected to their loads (only for Multipin Connector versions).

- **Status Overcurrent Bit:** 0÷5 V (only PCB modules)
- **Status On/Off Bit:** 0÷5 V (only PCB modules)
- **Protection against short circuits, sparks and humidity** (only PCB modules)

Ripple and Noise Behaviour

Fast, switched mode power delivery allow high efficiency conversion in switching generators, but creates wideband harmonic energy too, and this undesirable energy appears as radiated and conducted components; actually, switching regulator output noise consist of coherent, high frequency residues directly related to the regulator's switching, and these unsought components are usually called noise.

All CAEN Multichannel power supplies are optimized in order to provide output voltage with low ripple and noise levels. Their contribution can be divided taking into account three different frequency ranges.

The main frequency oscillation of the converter. CAEN power supplies features, on the output line, a filter that attenuates the high frequency components by some tens of dB depending on the components used. The switching frequency of CAEN power supplies ranges from some tens of kHz to about 300 kHz so, in case of frequencies around the fundamental and the switching harmonic, the spectrum amplitude can be reduced to few mV. This component depends on the load so it became less significant as the load is reduced.

Contribution from non-ideal electronic components present in the feedback circuit. This noise component sits in the 10 Hz –few kHz frequency range. Several possible channel control layers can be used, i.e. current set point feedback, Vmax loop, Imax loop e other dedicated controls implemented on specific channel typology. Working on the stabilization in terms of amplitude and phase, the peak-to-peak value of this component can be reduced to few mV.

The last component includes the **frequencies between about few Hz fractions (about 0.01) to 10 Hz** and typically are neglected in the spectroscopy applications. A possible contribution of the order of some tens of millivolts on the output voltage can come from the reference voltage generator and its control circuit. In this range, solutions that can be applied in all possible application do not exist. A detailed study of the circuit has to be performed and a specific solution could be provided.

Contribution coming from lower frequency ranges are typically related to a change of temperature that can produce a drift of the output voltage. If the mathematical correlation between the channel Vout (or Vset) and the environmental temperature has been established, a temperature control loop would allows to suppress this drift. Ripple and noise frequency ranges are divided during CAEN test measurements as follows:

- $f < 10$ Hz to check the power supply long term and thermal stability
- $10 \text{ Hz} < f < 10 \text{ kHz}$ in which many components contribute such as 50 Hz main supply and the single channel feedback loop circuit
- $f > 10 \text{ kHz}$ in which the main contribution is given by the power supply switching frequency.

Ripple, Noise and Validation Measurements

Every CAEN Power Supply is fully tested before shipping, according to specifications described by the designers, and doesn't need any further check. It is possible, anyway, to schedule a periodic service by contacting our maintenance division and organize repairs, verification or recalibrations. Tests are performed by skilled personnel

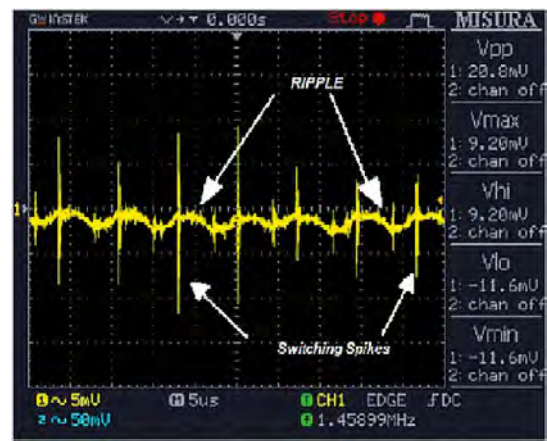

Figure 4: Example of possible power supply noise pattern

with very long experience, but CAEN provides also some dedicated documentation that describes some general purpose “guidelines”, about how to test each power supply specification in a thorough and safe way, that apply to all CAEN standard power supplies. Technicians usually refer to specific internal procedures to perform factory checks, and at the end of every inspection a specific test report, including rated values and acceptance levels, is filled.

As example we will describe here how the ripple measurements are performed by CAEN.

- Let's define **ripple** as the amount of AC, narrowband, switching frequency that is superimposed on the DC output voltage.
- Let's define **switching spikes** as the wideband, switching frequency, rapid oscillations superimposed on the ripple.
- Let's define **noise** as the sum of ripple and switching spikes.

You can specify noise in a switching regulator's output in a large number of ways: it is sometimes referred to as the maximum AC voltage expressed as RMS percentage of the rated DC output voltage at full load, while in industrial environment they often describe peak-to-peak noise in a 20 MHz bandpass, but, as realistically electronic systems are quite jammed by spectral energy also beyond 20 MHz, this specification doesn't sound adequate; considering that characteristic switching frequency in CAEN high voltage power supplies is some hundreds of kHz, and in order to take in account the several frequency components of switching spikes too, it seems appropriate to specify peak-to-peak noise in a verified 100 MHz bandwidth.

Reliable low level measurements in this bandpass require careful instrumentation choice and connection practices, and in fact our studies began by selecting proper test instrumentation and verifying bandwidth and noise of the entire setup; we typically consider a purely resistive load, namely the worst case, as, for capacitor input filter networks, ripple is directly proportional to load current, decreasing in value with decreasing current. CAEN power supplies have very low high frequency (tens to hundreds kHz) ripple, in the order of some units or tens of mV.

Required instrumentation

Very low level measurements require that test device do not introduce errors or noise; for this reason every test device has been designed in order not to invalidate the parameters verification. CAEN high voltage ripple measure setups provide therefore specifically engineered circuits, yearly verified and calibrated, described hereinafter.

- **CAEN HV splitter:** it is a simple insulated shunt, allowing to connect all the devices together. Connectors are chosen on the base of required voltage insulation and current rate.
- **CAEN ripple checker:** it basically consists of a DC blocking capacitor, which allows measurement of the ripple voltage using an AC RMS voltmeter or an oscilloscope.

A simplified schematic is shown in Figure 5.

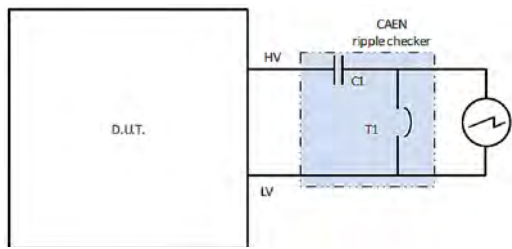

Figure 5: A simplified scheme of the CAEN ripple checker

Conceptually CAEN ripple checker consists of a capacitor of adequate value and of a switch or an equivalent solution that protect the measurement instrument:

- the switch is normally closed to prevent oscilloscope from damage during transients, and it is open at regime; it can be manually operated or implemented by remote control via relays.
- C1 must be capable of withstanding the maximum voltage to be applied, and has to be chosen to pass the lowest frequencies of interest without attenuation.
- **CAEN HV voltmeter:** it is a verified calibration, high voltage insulation voltmeter, with high input impedance (hundreds to thousands M Ω) and proper input connector.
- **CAEN HV load:** dimensioning the load is a straightforward task, but it may not be an easy task because of the high voltages involved and power considerations
- **Oscilloscope:** on the basis of our considerations regarding a 100 MHz verified band, it seems a proper choice to use a 300 MHz oscilloscope; maximum y-axis sensitivity should be 5 mV to discriminate very low signals.

Test setup

The measurement setup has been prepared as shown in Figure 6

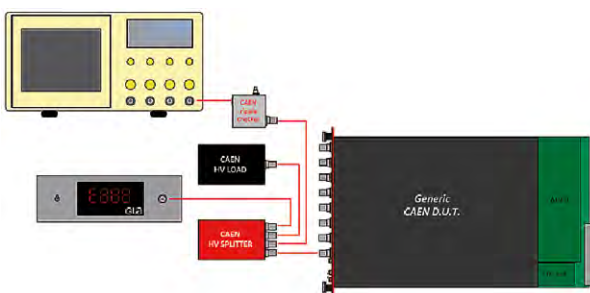

Figure 6: Ripple and noise measurement setup

Measurement procedure example

An example of a two-steps measurement procedure performed is the following:

Step 1. Oscilloscope settings:

- acquisition mode: peak detect

- band limit: off
- channel sensitivity: minimum
- time base: Fsw-1/div as to see at least some periods avoiding aliasing artifacts
- trigger mode: single sequence
- trigger threshold: expected threshold
- coupling: dc

Output voltage set at 10% (50%, 90%) of full range for channel under test, the relevant load connected, peak-to-peak ripple value read on the oscilloscope and snapshot saved providing the threshold data.

Step 2. Oscilloscope Settings:

- acquisition mode: peak detect
- band limit: off
- channel sensitivity: minimum
- time base: 10 msec/div as to investigate low frequency behaviour
- trigger mode: single sequence
- trigger threshold: expected threshold
- coupling: dc

Output voltage set at 10% (50%, 90%) of full range for channel under test, the relevant load connected, peak-to-peak ripple value read on the oscilloscope and snapshot saved providing the threshold data.

A typical measurement output is shown in Figure 7.

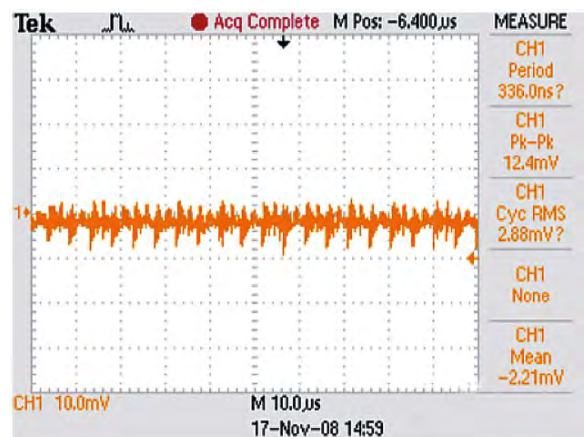
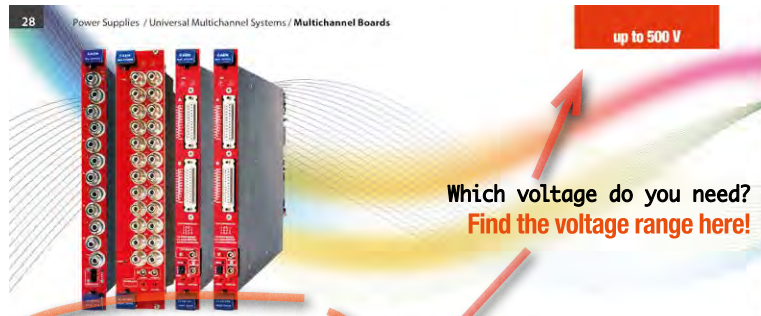

Figure 7: Typical output of a CAEN power supply noise and ripple measurement

How to find your Power Supply

Do you have a specific detector to power or do you just need a general purpose board? Look at the section title!
 We have many boards designed for specific applications!

Have a look at the family key features



NEW A1539 - A154x - A704x - A151x up to 500 V High Voltage Family

The ultimate solution for your detector: Power, Resolution and Flexibility in three new families of High Voltage Power Supply

Features

- 12/24/32 independently controllable High Voltage channels
- 2 different channel grounding:
 - Common Ground (AG5xx)
 - Common Floating return (A1539 and A154x)
- 10 models available:
 - Maximum Voltage: 100 V or 500 V
 - Maximum Current 1 mA, 10 mA or 1 mA/100 µA (dual range boards)
- DB25 Multi pin or SHV coaxial connectors
- Available with positive, negative or mixed polarity
- 1 mA in Overcurrent condition

Overview

A1539 / A154x family house 32, 24 or 12 independent high voltage channels available with either positive, negative or mixed polarity compatible with all CAEN Universal Multichannel Power Supply Systems. CAEN provides 2 different channel grounding: A1539/A154x (Common Floating Return) and AG5xx (Common Ground). Common Floating Return allows on-detector grounding reducing the noise level; the floating return is insulated from the crate earth up to ±50 V (with a 65 V hardware limit). The boards are available in different versions equipped with SHV or DB25 connectors. The output voltage range is 0 ÷ 100 V (A1539/40/40H - AG539/40) or 0 ÷ 500 V (A1541/42/42H - AG541/42) with 1 mV monitor resolution. The maximum output current is 10 mA, (200 nA step) with 10 nA monitor resolution for the A1539/41/41H while is 1 mA, (20 nA step) with 1 nA monitor resolution for the A1540/42/42H. The A1541H/42H boards are dual range boards: maximum output current 100 µA (20 nA step) with 100 pA monitor resolution. The boards are available with either positive or negative output polarity. Mixed version with 6/12 positive and 6/12 negative channels are also available. The boards are provided with both current and voltage protections. If overcurrent occurs, the relevant channel can be programmed either to turn off after a programmable trip time or to keep on providing the maximum allowed current; this particular feature allows the modules to work as current generator. Channel can be enabled or disabled through the Interlock logic.

the boards belonging to the family are listed together with an

compare

	Max Output V (V)	Max Output I (mA)	Vset Resolution (mV)	Imon Resolution (nA)	Ripple Typ. (mVpp)	Max Power per Channel (W)	# of channels
9/AG539	100	10	10	10	< 5	1	12/24/32
0/AG540	100	1	10	1	< 3	0.1	12/24/32
0H	100	1/0.1	10	1/0.1	< 3	0.1	12/24/32
1/AG541	500	10	10	10	< 5	5	12/24/32
1/AG542	500	1	10	1	< 3	0.5	12/24/32
	500	1/0.1	10	1/0.1	< 3	0.5	12/24/32
7040	100	500	10	1	< 5	50	48

How much Current does your application require?

Interested in Set and Monitor resolution? You find them here!

Worried about the noise? Look at the ripple levels

How much power do you need? You find it here!

How many channels do you need? Here you find the board channel number

Is grounding a major concern? Look at the different options here!

And finally choose your model!

up to 500 V

Power Supplies / Universal Multichannel Systems

Single Range Dual Range Featured Products

Model	Description
NEW A1539	12/24/32 Channels 100 V/10 mA Common Floating Return Boards
NEW A1540	12/24/32 Channels 100 V/1 mA Common Floating Return Boards
NEW AC539	12/24/32 Channels 100 V/10 mA Common Ground Boards
NEW AC540	12/24/32 Channels 100 V/1 mA Common Ground Boards
NEW A1541	12/24/32 Channels 500 V/10 mA Common Floating Return Boards
NEW A1542	12/24/32 Channels 500 V/1 mA Common Floating Return Boards
NEW A1541	12/24/32 Channels 500 V/10 mA Common Floating Return Boards

High Resolution Common Floating Return Common Ground Individual Floating Full Floating



A151xB - A251x

Low Voltage Boards Family

Redefining the low voltage: extended flexibility with parallelizable channels and unprecedented digital control loop

Features

- 6 or 8 individual full floating channels
- Up to 15 V of maximum voltage
- High resolution on voltage set
- Programmable TRIP parameter
- Programmable ramp up / down
- Current generator operation in overcurrent condition
- Overcurrent programmable protections
- Individual remote sense lines
- Individual Line Drop Recovery (only A151x family)
- 50 W Max channel output power (only A251x family)
- Full Digital PID Control Loop (only A251x family)
- 1/10 mV voltage monitor resolution
- Up to 1 mA current monitor resolution
- Voltage ripple smaller than 5/10 mVpp

In the following tables all the boards belonging to the family are listed together with an overview of the relevant parameters and of all the available Ordering Options.

Model Compare

Model	Max Output V (V)	Max Output I (A)	Vset Resolution (mV)	Imon Resolution (mA)	Ripple Typ. (mVpp)	Max Power per Channel (W)	# of channels
A1518B	4.5	6	10	1	< 5	27	6
A1517B	7	4	10	1	< 5	28	6
A1513B	10	2.7	10	1	< 5	27	6
A1516B	15	1.5	10	1	< 5	23	6
A2517	5	15	1	1	< 10	50	8
A2518	8	10	1	1	< 10	50	8
A2519	15	5	1	1	< 10	50	8

Overview

The family of low voltage (LV) power supplies includes single width boards housing 6 or 8 floating channels. The boards are designed to provide maximum voltages from 4.5 to 15 V, with up to 1 mV set and monitor resolution.

The power supply boards A251x can provide output power up to 50 W per channel that can be connected in parallel with modularity 2 or 4 to obtain higher output power. Two possible front panels are available for these board families. Channels feature a PID (Proportional-Integrative-Derivative) digital controller, that allows to optimize the control loop to any load. The voltage drop over the cables can be recovered by using either the featured Remote Sensing Lines (A251x family), to be connected on the load for sensing the drop, or an automatic Line Drop Recovery system (the A151xB family is equipped with both features).

The boards are provided with both current and voltage protections. If overcurrent occurs, the relevant channel can be programmed either to turn off after a programmable trip time or to remain on and to provide the maximum allowed current. This particular feature allows the module to perform as a current generator. A global enable/disable connector allows to disable the channels and it is also possible, via front panel logic signals, to enable individually each channel.

The voltage ramp rates may be set independently for each channel. Moreover the individual floating channels allow on-detector grounding, thus allowing to reduce the noise level. Output channels are delivered through DB37 or D-sub 8 (on A251x family) connectors.

Ordering Options

S = Single width (5 TE wide)
D = Double width (10 TE wide)

Code	Description	S/D
WA1518AXAAAA	A1518B - SYx527 L.V. channels 4.5 V 6 A Individual Floating (6 ch)	S
WA1517AXAAAA	A1517B - SYx527 L.V. channels 7 V 4 A Individual Floating (6 ch)	S
WA1513AXAAAA	A1513B - SYx527 L.V. channels 10 V 2.7 A Individual Floating (6 ch)	S
WA1516AXAAAA	A1516B - SYx527 L.V. channels 15 V 1.5 A Individual Floating (6 ch)	S
WA2517XAAAAA	A2517 - SYx527 L.V. channels 5V 15A (50W) - Individual Floating (8 ch)	S
WA2518XAAAAA	A2518 - SYx527 L.V. channels 8V 10A (50W) - Individual Floating (8 ch)	S
WA2518AXAAAA	A2518A - SYx527 L.V. channels 8V 10A (50W) - DB37 conn. Individual Floating (8 ch)	S
WA2519XAAAAA	A2519 - SYx527 L.V. channels 15V 5A (50W) - Individual Floating (8 ch)	S
WA2519AXAAAA	A2519A - SYx527 L.V. channels 15V 5A (50W) - DB37 conn. Individual Floating (8 ch)	S

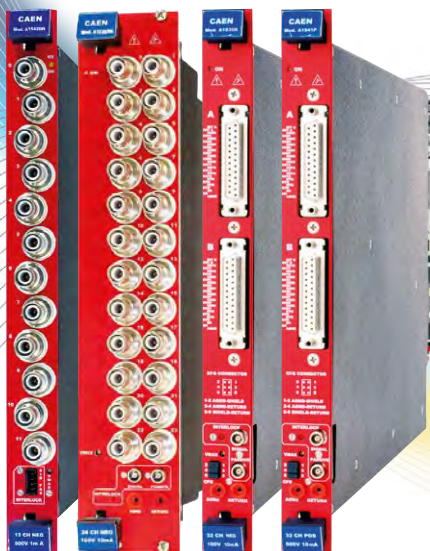
**NEW**

A1539 - A154x - A704x - A151x

up to 500 V High Voltage Family

The ultimate solution for your detector: Power, Resolution and Flexibility in three new families of High Voltage Power Supply

Features

- 12/24/32 independently controllable HV channels
- 2 different channel grounding:
 - Common Ground (AG5xx)
 - Common Floating return (A1539 and A154x)
- 10 models available:
 - Maximum Voltage: 100 V or 500 V
 - Maximum Current 1 mA, 10 mA or 1 mA/100 μ A (dual range boards)
- DB25 Multi pin or SHV coaxial connectors
- Available with positive, negative or mixed polarity
- 1 mV voltage monitor resolution
- Current monitor resolution up to 100 pA
- Low Ripple
- Independently programmable for each channel:
 - Output voltage (10 mV resolution)
 - Current limit (200/20 nA resolution)
 - Ramp up/down (1 \div 50/100 V/sec)
 - TRIP parameter
- Current generator operation in Overcurrent condition

In the following table all the boards belonging to the family are listed together with an overview of the relevant parameters.

Overview

A1539 / A154x family house 32, 24 or 12 independent High Voltage channels available with either positive, negative or mixed polarity compatible with all CAEN Universal Multichannel Power Supply Systems.

CAEN provides 2 different channel grounding: A1539/A154x (Common Floating Return) and AG5xx (Common Ground). Common Floating Return allows on-detector grounding reducing the noise level; the floating return is insulated from the crate earth up to ± 50 V (with a 65 V hardware limit). The boards are available in different versions equipped with SHV or DB25 connectors. The output voltage range is 0 \div 100 V (A1539/40/40H - AG539/40) or 0 \div 500 V (A1541/42/42H - AG541/42) with 1 mV monitor resolution. The maximum output current is 10 mA, (200 nA step) with 10 nA monitor resolution for the A1539/41/41H while is 1 mA, (20 nA step) with 1 nA monitor resolution for the A1540/42/42H. The A1541H/42H boards are dual range boards: maximum output current 100 μ A (20 nA step) with 100 pA monitor resolution. The boards are available with either positive or negative output polarity. Mixed version with 6/12 positive and 6/12 negative channels are also available. The boards are provided with both current and voltage protections. If overcurrent occurs, the relevant channel can be programmed either to turn off after a programmable trip time or to remain on and to provide the maximum allowed current. This particular feature allows the module to perform as a current generator. Channels may be enabled or disabled via the Interlock logic.

The HV Ramp up/down rates may be selected independently for each channel in the 1 \div 50 V/s range (1 V/s step) for the x539 and x541 family and in the 1 \div 100 V/s range (1 V/s step) for the x540 and x542 family. A704x and A151x families will be detailed in the dedicated section.

Model Compare

Model	Max Output V (V)	Max Output I (mA)	Vset Resolution (mV)	Imon Resolution (nA)	Ripple Typ. (mVpp)	Max Power per Channel (W)	# of channels
A1539/AG539	100	10	10	10	< 5	1	12/24/32
A1540/AG540	100	1	10	1	< 3	0.1	12/24/32
A1540H	100	1/0.1	10	1/0.1	< 3	0.1	12/24/32
A1541/AG541	500	10	10	10	< 5	5	12/24/32
A1542/AG542	500	1	10	1	< 3	0.5	12/24/32
A1542H	500	1/0.1	10	1/0.1	< 3	0.5	12/24/32
A7040/AG7040	100	0.5	10	1	< 5	0.05	48

Model	Max Output V (V)	Max Output I (mA)	Vset Resolution (mV)	Imon Resolution (nA)	Ripple Typ. (mVpp)	Max Power per Channel (W)	# of channels
A7042/AG7042	500	0.5	10	1	< 5	0.25	48
A1510	100	10/1	20	1/0.1	< 15	1	12
A1519B	250	1/0.1	50	0.1/0.01	< 30	0.25	12
A1511B	500	10/1	100	1/0.1	< 30	5	12
A1512	500	1/0.1	100	0.1/0.01	< 30	0.5	12
A1520P	500	15	1	0.025	< 20	7.5	12

Single Range			Dual Range			Featured Products		
Model	Description		High Resolution	Common Floating Return	Common Ground	Individual Floating	Full Floating	
NEW A1539	12/24/32 Channel 100 V/10 mA Common Floating Return Boards			●				
NEW A1540	12/24/32 Channel 100 V/1 mA Common Floating Return Boards			●				
NEW AG539	12/24/32 Channel 100 V/10 mA Common Ground Boards				●			
NEW AG540	12/24/32 Channel 100 V/1 mA Common Ground Boards				●			
NEW A1541	12/24/32 Channel 500 V/10 mA Common Floating Return Boards			●				
NEW A1542	12/24/32 Channel 500 V/1 mA Common Floating Return Boards			●				
NEW AG541	12/24/32 Channel 500 V/10 mA Common Ground Boards				●			
NEW AG542	12/24/32 Channel 500 V/1 mA Common Ground Boards				●			

Single Range			Dual Range			Featured Products		
Model	Description		High Resolution	Common Floating Return	Common Ground	Individual Floating	Full Floating	
NEW A1540H	12/24/32 Channels 100 V, 1 mA/100 µA Common Floating Return Dual Range Boards		●	●				
NEW A1542H	12/24/32 Channels 500 V, 1 mA/100 µA Common Floating Return Dual Range Boards		●	●				

Single Range			Dual Range			Featured Products		
Model	Description		High Resolution	Common Floating Return	Common Ground	Individual Floating	Full Floating	
COMING SOON A7040	Solution for High Density Detectors			●				
COMING SOON AG7040	Solution for High Density Detectors				●			
NEW A7042	Solution for High Density Detectors			●				
NEW AG7042	Solution for High Density Detectors				●			
A151x - A1520P	Solution for Silicon Detectors and APDs					●	●	

Ordering Options - A1539 / A154x

S = Single width (5 TE wide)
D = Double width (10 TE wide)

Model	Code	Description	S/D	
A1539	WA1539DXAAAA	A1539DN - SYx527 H.V. channel -100 V 10 mA - SHV Conn. common floating (12 ch)	S	
	WA1539DXMAAA	A1539DM - SYx527 H.V. channel (6ch +100V 10mA, 6ch -100V 10mA) - SHV Conn. common floating	S	
	WA1539DXPAAA	A1539DP - SYx527 H.V. channel +100 V 10 mA - SHV Conn. common floating (12 ch)	S	
	WA1539LXAAAA	A1539LN - SYx527 H.V. channel -100 V 10 mA - Multipin Conn. common floating (24 ch)	S	
	WA1539LXPAAA	A1539LP - SYx527 H.V. channel +100 V 10 mA - Multipin Conn. common floating (24 ch)	S	
	WA1539SXAAAA	A1539SN - SYx527 H.V. channel -100 V 10 mA - SHV Conn. common floating (24 ch 10TE wide)	D	
	WA1539SXMAAA	A1539SM - SYx527 H.V. channel (12ch +100V 10mA, 12ch -100V 10mA) - SHV Conn. common floating (10TE)	D	
	WA1539SXPAAA	A1539SP - SYx527 H.V. channel +100 V 10 mA - SHV Conn. common floating (24 ch 10TE wide)	D	
	WA1539XAAAAA	A1539N - SYx527 H.V. channel -100 V 10 mA - Multipin Conn. common floating (32 ch)	S	
	WA1539XPAAAA	A1539P - SYx527 H.V. channel +100 V 10 mA - Multipin Conn. common floating (32 ch)	S	
	A1540	WA1540DXAAAA	A1540DN - SYx527 H.V. channel -100 V 1 mA - SHV Conn. common floating (12 ch)	S
		WA1540DXMAAA	A1540DM - SYx527 H.V. channel (6ch +100V 1mA, 6ch -100V 1mA) - SHV common floating	S
WA1540DXPAAA		A1540DP - SYx527 H.V. channel +100 V 1 mA - SHV Conn. common floating (12 ch)	S	
WA1540LXAAAA		A1540LN - SYx527 H.V. channel -100 V 1 mA - Multipin Conn. common floating (24 ch)	S	
WA1540LXPAAA		A1540LP - SYx527 H.V. channel +100 V 1 mA - Multipin Conn. common floating (24 ch)	S	
WA1540SXAAAA		A1540SN - SYx527 H.V. channel -100 V 1 mA - SHV Conn. common floating (24 ch 10TE wide)	D	
WA1540SXMAAA		A1540SM - SYx527 H.V. channel (12ch +100V 1mA, 12ch -100V 1mA) - SHV common floating (10TE wide)	D	
WA1540SXPAAA		A1540SP - SYx527 H.V. channel +100 V 1 mA - SHV Conn. common floating (24 ch 10TE wide)	D	
WA1540XAAAAA		A1540N - SYx527 H.V. channel -100 V 1 mA - Multipin Conn. common floating (32 ch)	S	
WA1540XPAAAA		A1540P - SYx527 H.V. channel +100 V 1 mA - Multipin Conn. common floating (32 ch)	S	
A1540H		WA1540HDXAAA	A1540HDN - SYx527 H.V. channel -100V 1mA/100µA (100pA res) - SHV Conn. common floating (12 ch)	S
		WA1540HDXMAA	A1540HDM - SYx527 H.V. (6ch +100V 1mA/100µA, 6ch -100V 1mA/100µA) (100pA res) - SHV Conn. comm float	S
		WA1540HDXPAA	A1540HDP - SYx527 H.V.channel +100V 1mA/100µA (100pA res) - SHV Conn. common floating (12 ch)	S
		WA1540HLXAAA	A1540HLN - SYx527 H.V. channel -100V 1mA/100µA (100pA res) - Multipin Conn. common floating (24 ch)	S
	WA1540HLXPAA	A1540HLP - SYx527 H.V. channel +100V 1mA/100µA (100pA res) - Multipin Conn. common floating (24 ch)	S	
	WA1540HSXAAA	A1540HSN - SYx527 H.V. channel -100V 1mA/100µA (100pA res) - SHV Conn. common floating (24 ch 10TE)	D	
	WA1540HSXMAA	A1540HSM - SYx527 H.V. (12ch +100V 1mA/100µA, 12ch -100V 1mA/100µA) (100pA res) SHV c. float (10TE)	D	
	WA1540HSXPAA	A1540HSP - SYx527 H.V. channel +100V 1mA/100µA (100pA res) - SHV Conn. common floating (24 ch 10TE)	D	
	WA1540HXAAAA	A1540HNN - SYx527 H.V. channel -100V 1mA/100µA (100pA res) - Multipin Conn. common floating (32 ch)	S	
	WA1540HXPAAA	A1540HNP - SYx527 H.V. channel +100V 1mA/100µA (100pA res) - Multipin Conn. common floating (32 ch)	S	
A1541	WA1541DXAAAA	A1541DN - SYx527 H.V. channel -500 V 10 mA - SHV Conn. common floating (12 ch)	S	
	WA1541DXMAAA	A1541DM - SYx527 H.V. channel (6ch +500V 10mA, 6ch -500V 10mA) - SHV Conn. common floating	S	
	WA1541DXPAAA	A1541DP - SYx527 H.V. channel +500 V 10 mA - SHV Conn. common floating (12 ch)	S	
	WA1541LXAAAA	A1541LN - SYx527 H.V. channel -500 V 10 mA - Multipin Conn. common floating (24 ch)	S	
	WA1541LXPAAA	A1541LP - SYx527 H.V. channel +500 V 10 mA - Multipin Conn. common floating (24 ch)	S	
	WA1541SXAAAA	A1541SN - SYx527 H.V. channel -500 V 10 mA - SHV Conn. common floating (24 ch 10TE wide)	D	

Ordering Options - A1539 / A154x - continued

S = Single width (5 TE wide)
D = Double width (10 TE wide)

Model	Code	Description	S/D	
A1541 continued	WA1541SXMAAA	A1541SM - SYx527 H.V. channel (12ch +500V 10mA, 12ch -500V 10mA) - SHV Conn. common floating (10TE)	D	
	WA1541SXPAAA	A1541SP - SYx527 H.V. channel +500 V 10 mA - SHV Conn. common floating (24 ch 10TE wide)	D	
	WA1541XAAAA	A1541N - SYx527 H.V. channel -500 V 10 mA - Multipin Conn. common floating (32 ch)	S	
	WA1541XPAAAA	A1541P - SYx527 H.V. channel +500 V 10 mA - Multipin Conn. common floating (32 ch)	S	
A1542	WA1542DXAAAA	A1542DN - SYx527 H.V. channel -500 V 1 mA - SHV Conn. common floating (12 ch)	S	
	WA1542DXMAAA	A1542DM - SYx527 H.V. channel (6ch +500V 1mA, 6ch -500V 1mA) - SHV common floating	S	
	WA1542DXPAAA	A1542DP - SYx527 H.V. channel +500 V 1 mA - SHV Conn. common floating (12 ch)	S	
	WA1542LXAAAA	A1542LN - SYx527 H.V. channel -500 V 1 mA - Multipin Conn. common floating (24 ch)	S	
	WA1542LXPAAA	A1542LP - SYx527 H.V. channel +500 V 1 mA - Multipin Conn. common floating (24 ch)	S	
	WA1542SXAAAA	A1542SN - SYx527 H.V. channel -500 V 1 mA - SHV Conn. common floating (24 ch 10TE wide)	D	
	WA1542SXMAAA	A1542SM - SYx527 H.V. channel (12ch +500V 1mA, 12ch -500V 1mA) - SHV common floating (10TE wide)	D	
	WA1542SXPAAA	A1542SP - SYx527 H.V. channel +500 V 1 mA - SHV Conn. common floating (24 ch 10TE wide)	D	
	WA1542XAAAA	A1542N - SYx527 H.V. channel -500 V 1 mA - Multipin Conn. common floating (32 ch)	S	
	WA1542XPAAAA	A1542P - SYx527 H.V. channel +500 V 1 mA - Multipin Conn. common floating (32 ch)	S	
	A1542H	WA1542HDXAAA	A1542HDN - SYx527 H.V. channel -500V 1mA/100µA (100pA res) - SHV Conn. common floating (12 ch)	S
		WA1542HDXMAA	A1542HDM - SYx527 H.V. (6ch +500V 1mA/100µA, 6ch -500V 1mA/100µA) (100pA res) - SHV Conn. comm float	S
WA1542HDXPAA		A1542HDP - SYx527 H.V. channel +500V 1mA/100µA (100pA res) - SHV Conn. common floating (12 ch)	S	
WA1542HLXAAA		A1542HNL - SYx527 H.V. channel -500V 1mA/100µA (100pA res) - Multipin Conn. common floating (24 ch)	S	
WA1542HLXPAA		A1542HLP - SYx527 H.V. channel +500V 1mA/100µA (100pA res) - Multipin Conn. common floating (24 ch)	S	
WA1542HSXAAA		A1542HSN - SYx527 H.V. channel -500V 1mA/100µA (100pA res) - SHV Conn. common floating (24 ch 10TE)	D	
WA1542HSXMAA		A1542HSM - SYx527 H.V. (12ch +500V 1mA/100µA, 12ch -500V 1mA/100µA) (100pA res) SHV c. float (10TE)	D	
WA1542HSXPAA		A1542HSP - SYx527 H.V. channel +500V 1mA/100µA (100pA res) - SHV Conn. common floating (24 ch 10TE)	D	
WA1542HXAAAA		A1542HN - SYx527 H.V. channel -500V 1mA/100µA (100pA res) - Multipin Conn. common floating (32 ch)	S	
WA1542HXPAAA		A1542HP - SYx527 H.V. channel +500V 1mA/100µA (100pA res) - Multipin Conn. common floating (32 ch)	S	

Model	Code	Description	S/D
AG539	WAG539DXAAAA	AG539DN - SYx527 H.V. channel -100 V 10 mA - SHV Conn. common ground (12 ch)	S
	WAG539DXMAAA	AG539DM - SYx527 H.V. channel (6ch +100V 10mA, 6ch -100V 10mA) - SHV Conn. common ground	S
	WAG539DXPAAA	AG539DP - SYx527 H.V. channel +100 V 10 mA - SHV Conn. common ground (12 ch)	S
	WAG539LXAAAA	AG539LN - SYx527 H.V. channel -100 V 10 mA - Multipin Conn. common ground (24 ch)	S
	WAG539LXPAAA	AG539LP - SYx527 H.V. channel +100 V 10 mA - Multipin Conn. common ground (24 ch)	S
	WAG539SXAAAA	AG539SN - SYx527 H.V. channel -100 V 10 mA - SHV Conn. common ground (24 ch 10TE wide)	D
	WAG539SXMAAA	AG539SM - SYx527 H.V. channel (12ch +100V 10mA, 12ch -100V 10mA) - SHV Conn. common ground (10TE)	D
	WAG539SXPAAA	AG539SP - SYx527 H.V. channel +100 V 10 mA - SHV Conn. common ground (24 ch 10TE wide)	D
	WAG539XAAAA	AG539N - SYx527 H.V. channel -100 V 10 mA - Multipin Conn. common ground (32 ch)	S
	WAG539XPAAAA	AG539P - SYx527 H.V. channel +100 V 10 mA - Multipin Conn. common ground (32 ch)	S

AG540	WAG540DXAAAA	AG540DN - SYx527 H.V. channel -100 V 1 mA - SHV Conn. common ground (12 ch)	S	
	WAG540DXMAAA	AG540DM - SYx527 H.V. channel (6ch +100V 1mA, 6ch -100V 1mA) - SHV Conn. common ground	S	
	WAG540DXPAAA	AG540DP - SYx527 H.V. channel +100 V 1 mA - SHV Conn. common ground (12 ch)	S	
	WAG540LXAAAA	AG540LN - SYx527 H.V. channel -100 V 1 mA - Multipin Conn. common ground (24 ch)	S	
	WAG540LXPAAA	AG540LP - SYx527 H.V. channel +100 V 1 mA - Multipin Conn. common ground (24 ch)	S	
	WAG540SXAAAA	AG540SN - SYx527 H.V. channel -100 V 1 mA - SHV Conn. common ground (24 ch 10TE wide)	D	
	WAG540SXMAAA	AG540SM - SYx527 H.V. channel (12ch +100V 1mA, 12ch -100V 1mA) - SHV Conn. common ground (10TE wide)	D	
	WAG540SXPAAA	AG540SP - SYx527 H.V. channel +100 V 1 mA - SHV Conn. common ground (24 ch 10TE wide)	D	
	WAG540XAAAA	AG540N - SYx527 H.V. channel -100 V 1 mA - Multipin Conn. common ground (32 ch)	S	
	WAG540XPAAAA	AG540P - SYx527 H.V. channel +100 V 1 mA - Multipin Conn. common ground (32 ch)	S	
	AG541	WAG541DXAAAA	AG541DN - SYx527 H.V. channel -500 V 10 mA - SHV Conn. common ground (12 ch)	S
		WAG541DXMAAA	AG541DM - SYx527 H.V. channel (6ch +500V 10mA, 6ch -500V 10mA) - SHV Conn. common ground	S
WAG541DXPAAA		AG541DP - SYx527 H.V. channel +500 V 10 mA - SHV Conn. common ground (12 ch)	S	
WAG541LXAAAA		AG541LN - SYx527 H.V. channel -500 V 10 mA - Multipin Conn. common ground (24 ch)	S	
WAG541LXPAAA		AG541LP - SYx527 H.V. channel +500 V 10 mA - Multipin Conn. common ground (24 ch)	S	
WAG541SXAAAA		AG541SN - SYx527 H.V. channel -500 V 10 mA - SHV Conn. common ground (24 ch 10TE wide)	D	
WAG541SXMAAA		AG541SM - SYx527 H.V. channel (12ch +500V 10mA, 12ch -500V 10mA) - SHV Conn. common ground (10TE)	D	
WAG541SXPAAA		AG541SP - SYx527 H.V. channel +500 V 10 mA - SHV Conn. common ground (24 ch 10TE wide)	D	
WAG541XAAAA		AG541N - SYx527 H.V. channel -500 V 10 mA - Multipin Conn. common ground (32 ch)	S	
WAG541XPAAAA		AG541P - SYx527 H.V. channel +500 V 10 mA - Multipin Conn. common ground (32 ch)	S	
AG542		WAG542DXAAAA	AG542DN - SYx527 H.V. channel -500 V 1 mA - SHV Conn. common ground (12 ch)	S
		WAG542DXMAAA	AG542DM - SYx527 H.V. channel (6ch +500V 1mA, 6ch -500V 1mA) - SHV common ground	S
	WAG542DXPAAA	AG542DP - SYx527 H.V. channel +500 V 1 mA - SHV Conn. common ground (12 ch)	S	
	WAG542LXAAAA	AG542LN - SYx527 H.V. channel -500 V 1 mA - Multipin Conn. common ground (24 ch)	S	
	WAG542LXPAAA	AG542LP - SYx527 H.V. channel +500 V 1 mA - Multipin Conn. common ground (24 ch)	S	
	WAG542SXAAAA	AG542SN - SYx527 H.V. channel -500 V 1 mA - SHV Conn. common ground (24 ch 10TE wide)	D	
	WAG542SXMAAA	AG542SM - SYx527 H.V. channel (12ch +500V 1mA, 12ch -500V 1mA) - SHV common ground (10TE wide)	D	
	WAG542SXPAAA	AG542SP - SYx527 H.V. channel +500 V 1 mA - SHV Conn. common ground (24 ch 10TE wide)	D	
	WAG542XAAAA	AG542N - SYx527 H.V. channel -500 V 1 mA - Multipin Conn. common ground (32 ch)	S	
	WAG542XPAAAA	AG542P - SYx527 H.V. channel +500 V 1 mA - Multipin Conn. common ground (32 ch)	S	

up to 500 V

A7040 - AG7040 - A7042 - AG7042

Solution for High Density Detectors

NEW

Unprecedented channel density for your detector

Overview

The new line of high density general purpose power supplies offers you all the safety, performance and control of a completely independent channel technology at the cost effective price of a distributor! A7040/A7042 family house 48 independent High Voltage channels available with either positive or negative polarity, compatible with the CAEN Universal Multichannel Power Supply Systems (SY1527, SY2527, SY3527, SY4527, SY5527).

CAEN provides 4 different models with different channel grounding: AG704x (Common Ground) and A704x (Common Floating Return). Common Floating Return allows on-detector grounding reducing the noise level; the floating return is insulated from the crate earth up to ± 50 V (with a 65 V hardware limit). AG704x and A704x are equipped with Radial Multipin connector. The output voltage range is $0 \div 100$ V (A7040/AG7040) or $0 \div 500$ V (A7042/AG7042), with 0.2 or 1 mV monitor resolution.

The maximum output current is 500 μ A, with up to 1 nA monitor resolution. The boards are provided with both current and voltage protections. If overcurrent occurs, the relevant channel can be programmed either to turn off after a programmable trip time or to remain on and to provide the maximum allowed current. This particular feature allows the module to perform as a current generator.

The maximum output voltage can be set through a potentiometer to a value which is common to all channels and can be read out via software. Channels may be enabled or disabled via the Interlock logic. The HV ramp-up and ramp-down rates may be selected independently for each channel in the $1 \div 50$ V/s range (1 V/s step) for the A7040 and in the $1 \div 100$ V/s range (1 V/s step) for the A7042.

In the following tables all the boards belonging to the family are listed together with an overview of the relevant parameters and of all the available Ordering Options.

Model Compare

	Model	Max Output V (V)	Max Output I (μ A)	Vset Resolution (mV)	Imon Resolution (nA)	Ripple Typ. (mVpp)	Max Power per Channel (mW)	# of channels
COMING SOON	A7040/AG7040	100	500	2	1	< 5	50	48
NEW	A7042/AG7042	500	500	10	1	< 5	250	48

Features

- 48 independently controllable HV channels
- 2 different channel grounding:
 - Common Ground (AG704x)
 - Common Floating return (A704x)
- 4 models available:
 - A7040/AG7040: $0 \div 100$ V (coming soon)
 - A7042/AG7042: $0 \div 500$ V
- 500 μ A maximum output current
- Radial 52 pin connector
- Available with positive or negative polarity
- 0.2 or 1 mV voltage monitor resolution
- 1 nA current monitor resolution
- Low Ripple
- Independently programmable for each channel:
 - Output voltage (10 mV resolution)
 - Current limit (1 nA resolution)
 - Ramp up/down ($1 \div 50$ and $1 \div 100$ V/s)
 - TRIP parameter

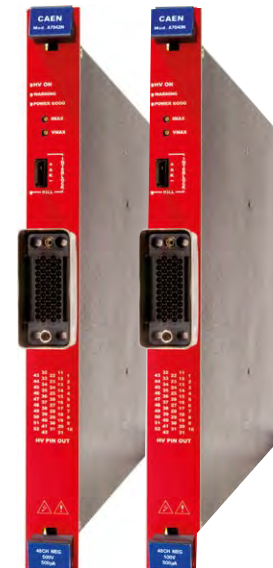

Ordering Options

S = Single width (5 TE wide)
D = Double width (10 TE wide)

Model	Code	Description	S/D
A7040	WA7040NXAAA4	A7040N - SYx527 H.V. channels -100 V 500 μ A - Multipin Conn. common floating (48 ch)	S
	WA7040PXAAA4	A7040P - SYx527 H.V. channels +100 V 500 μ A - Multipin Conn. common floating (48 ch)	S
AG7040	WAG7040NXAAA4	AG7040N - SYx527 H.V. channels -100 V 500 μ A - Multipin Conn. common ground (48 ch)	S
	WAG7040PXAAA4	AG7040P - SYx527 H.V. channels +100 V 500 μ A - Multipin Conn. common ground (48 ch)	S
A7042	WA7042NXAAA4	A7042N - SYx527 H.V. channels -500 V 500 μ A - Multipin Conn. common floating (48 ch)	S
	WA7042PXAAA4	A7042P - SYx527 H.V. channels +500 V 500 μ A - Multipin Conn. common floating (48 ch)	S
AG7042	WAG7042NXAAA4	AG7042N - SYx527 H.V. channels -500 V 500 μ A - Multipin Conn. common ground (48 ch)	S
	WAG7042PXAAA4	AG7042P - SYx527 H.V. channels +500 V 500 μ A - Multipin Conn. common ground (48 ch)	S

A151x - A1520P

Solution for Silicon Detectors and APDs

Full floating channels for Silicon Detectors and Avalanche Photodiodes

Overview

This family of High Voltage power supplies includes single or double width boards housing 12 independent output channels. The boards are designed to provide voltage up to 100, 250 and 500 V, with up to 1 mV or set and monitor voltage resolution. The boards are provided with both current and voltage protections. If overcurrent occurs, the relevant channel can be programmed either to turn off after a programmable trip time or to remain on and to provide the maximum allowed current. This particular feature allows the module to perform as a current generator. The A151x board channels can be individually enabled or disabled. The voltage ramp rates may be set independently for each channel. The A151x boards feature individual fully floating channels allowing on-detector grounding, thus providing the best reduction of the voltage ripple and avoiding ground-loops which may increase noise level.

Moreover the A151x boards, specifically designed for the double-side silicon detector features on the output connector a $\frac{1}{2}$ CHx reference: it is a reference voltage (high impedance, thus not available as a power source) whose value is $\frac{1}{2}|CHx+|$ and allow a symmetric supply to the detector.

The A1520P board, specifically designed for the APDs, features an High Voltage setting/monitoring resolution, an outstanding stability performance and is equipped with sense lines to compensate the voltage drop along the cables.

Features

- 12 independent single and dual range HV channels
- Either DB or AMP Multipin connectors
- Full floating channels
- Available with floating polarity
- Individual Enable
- Up to 10 nA current set / monitor resolution
- Up to 1 mV voltage set / monitor resolution
- Programmable TRIP parameter
- Current generator operation in overcurrent condition
- Specific features for double-side silicon detectors (A151x)
- Specific features for APD detectors (A1520P)



In the following tables all the boards belonging to the family are listed together with an overview of the relevant parameters and of all the available Ordering Options.

Model Compare

Model	Max Output V (V)	Max Output I (mA)	Vset Resolution (mV)	Imon Resolution (μ A)	Ripple Typ. (mVpp)	Max Power per Channel (W)	# of channels
A1510	100	10/1	20	1/0.1	< 15	1	12
A1519B	250	1/0.1	50	0.1/0.01	< 30	2.5	12
A1511B	500	10/1	100	1/0.1	< 30	5	12
A1512	500	1/0.1	100	0.1/0.01	< 30	0.5	12
A1520P	500	15	1	0.025	< 20	7.5	12

Ordering Options

S = Single width (5 TE wide)
D = Double width (10 TE wide)

Code	Description	S/D
WA1510XAAAAA	A1510 - SYx527 H.V. channels 100 V 10 mA Individual Floating (12 ch)	S
WA1519XAAAAA	A1519B - SYx527 H.V. channels 250 V 1/0.1 mA Individual Floating (12 ch)	S
WA1511XAAAAA	A1511B - SYx527 H.V. channels 500 V 10/1 mA Individual Floating (12 ch)	S
WA1512XAAAAA	A1512 - SYx527 H.V. channels 500 V 1/0.1 mA Individual Floating (12 ch)	S
WA1520XPAAAAA	A1520P - SYx527 H.V. channels +500 V 15 mA Individual Floating (12 ch)	D

up to 4 kV

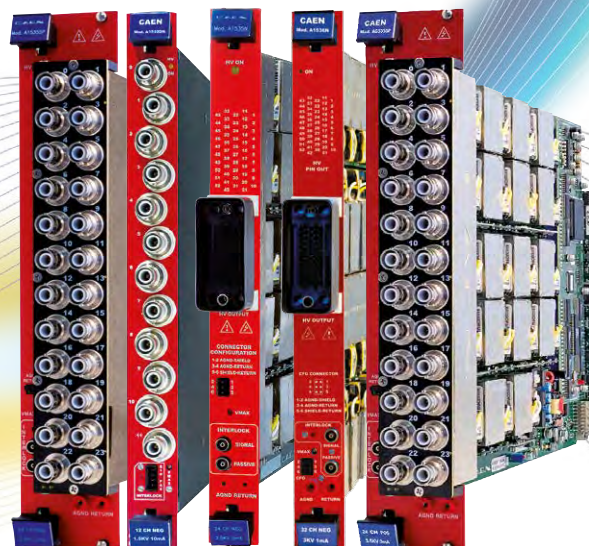

A15xx - A18xx - AP932 - A7xxx

up to 4kV High Voltage Family

If you have a Photomultiplier, then we have a solution for you!

Features

- From 12 to 48 independently controllable HV channels
- Both Radial Multipin or SHV connectors
- Available with either positive, negative or mixed polarity
- Up to 100 pA current set / monitor resolution
- Up to 5 mV voltage set / monitor resolution
- Programmable TRIP parameter
- Boards are available with voltage ripple < 5 mVpp
- Current generator operation in overcurrent condition
- Available output current up to 30 mA

Overview

This family of High Voltage power supplies includes single or double width boards housing up to 48 output channels. The boards are designed to provide voltage up to 4 kV, with up to 5 mV set and monitor resolution. All boards are provided with both current and voltage protections. If overcurrent occurs, the corresponding channel may be programmed to either turn off after a programmable trip time or to remain on and provide the maximum allowable current. Channels may be enabled or disabled through the Interlock logic. The voltage ramp rates may be set independently for each channel.

Customers may select the grounding design based on their needs. For example, a Common Floating Return grounding configuration is available for applications with more rigorous stability demands. Output channels are delivered through with either Radial Multipin or SHV connectors.

Single Range		Dual Range	Featured Products		High Resolution	Common Floating Return	Common Ground	Individual Floating	Full Floating
Model	Description								
A1538D	12 Channel 1.5 kV/10 mA (12W) Common Floating Return Board					●			
AG538D	12 Channel 1.5 kV/10 mA (12W) Common Ground Board						●		
A1536	12/24/32 Channel 3 kV/1 mA Common Floating Return Boards					●			
AG536	12/24/32 Channel 3 kV/1 mA Common Ground Boards						●		
AP932	1 Channel 3 kV/30mA Individual Floating Board (SHV conn)							●	
A1535	12/24 Channel 3.5 kV/3 mA (8 W) Common Floating Return Boards					●			
AG535	12/24 Channel 3.5 kV/3 mA (6 W) Common Ground Boards						●		

Single Range	Dual Range	Featured Products		High Resolution	Common Floating Return	Common Ground	Individual Floating	Full Floating
Model	Description							
A1821	12 Channel 3 kV, 200/20 µA Common Ground Dual Range Board				●			
A1821H	12 Channel 3 kV, 200/10 µA Common Ground Dual Range Board				●			
A1833	12 Channel 3 kV/3mA, 4 kV/2 mA, 4 kV/0.2 mA Common Ground Dual Range Board					●		

Single Range

Dual Range

Featured Products

High Resolution	Common Floating Return	Common Ground	Individual Floating	Full Floating
●	●	●		●
●	●	●		●

	Model	Description	High Resolution	Common Floating Return	Common Ground	Individual Floating	Full Floating
NEW	A7030-AG7030	General Purpose High Density Family		●	●		
NEW	A1515-A1515TG-A1515QG	Solution For Gas Electron Multiplier Detectors					●
NEW	A7236-AG7236-A7435-AG7435	General Purpose High Power and High Resolution Power Supplies	●	●	●		●

In the following tables all the boards belonging to the family are listed together with an overview of the relevant parameters and of all the available Ordering Options.

Model Compare

Model	Max Output V (kV)	Max Output I (mA)	Vset Resolution (mV)	Imon Resolution (nA)	Ripple Typ. (mVpp)	Max Power per Channel (W)	# of channels
A1538D	1.5	10	50	200	< 20	12	12
AG538D	1.5	10	50	200	< 20	12	12
A1536	3	1	100	50	< 10	3	12/24/32
AG536	3	1	100	50	< 10	3	12/24/32
A1821	3	0.2/0.02	250	20/2	< 30	0.6	12
A1821H	3	0.2/0.01	250	20/1	< 30	0.6	12
A1833	3/4	3/2/0.2	250	200/20	< 30	9	12
AP932	3	30	100	1000	< 30	90	1
A1535	3.5	3	500	500	< 20	8	12/24
AG535	3.5	3	500	500	< 20	8	12/24
A7236	3.5	1.5	5	1	< 10	4	32
AG7236	3.5	1.5	5	1	< 10	4	32
A7435	3.5	3.5	5	5	< 15	9	24
AG7435	3.5	3.5	5	5	< 15	9	24
A7030	3	1	50	2	< 5	1.5	12/24/36/48
AG7030	3	1	50	2	< 5	1.5	12/24/36/48
A1515TG	1	1/0.1	20	1/0.1	< 10 (CM) < 5 (DM)	0.8	14
A1515QG	1	1/0.1	20	1/0.1	< 10 (CM) < 5 (DM)	0.8	16
A1515	1	1/0.1	20	1/0.1	< 10 (CM) < 5 (DM)	0.8	16

Ordering Options

S = Single width (5 TE wide)
D = Double width (10 TE wide)

Model	Code	Description	S/D
A1538D	WA1538DXAAAA	A1538DN - SYx527 negative H.V. -1.5 kV 10 mA 12W - SHV Connector common floating (12 ch)	S
	WA1538DXPAAA	A1538DP - SYx527 positive H.V. +1.5 kV 10 mA 12W - SHV Connector common floating (12 ch)	S
AG1538D	WAG538DXAAAA	AG538DN - SYx527 negative H.V. -1.5 kV 10 mA 12W - SHV Connector common ground (12 ch)	S
	WAG538DXPAAA	AG538DP - SYx527 positive H.V. +1.5 kV 10 mA 12W - SHV Connector common ground (12 ch)	S
A1536	WA1536DXAAAA	A1536DN - SYx527 H.V. channels -3 kV 1 mA - SHV Conn. common floating (12 ch)	S
	WA1536DXMAAA	A1536DM - SYx527 H.V. channels (6ch +3kV 1mA, 6ch -3kV 1mA) - SHV Conn. common floating	S
	WA1536DXPAAA	A1536DP - SYx527 H.V. channels +3 kV 1 mA - SHV Conn. common floating (12 ch)	S
	WA1536LXAAAA	A1536LN - SYx527 H.V. channels -3 kV 1 mA - Multipin Conn. common floating (24 ch)	S
WA1536LXPAAA	A1536LP - SYx527 H.V. channels +3 kV 1 mA - Multipin Conn. common floating (24 ch)	S	
WA1536SVXAAA	A1536SVN - SYx527 H.V. channels -3 kV 800µA - SHV Conn. common floating (24 ch 10TE wide)	D	
WA1536SVXPAA	A1536SVP - SYx527 H.V. channels +3 kV 800µA - SHV Conn. common floating (24 ch 10TE wide)	D	

Ordering Options - continued

Model	Code	Description	S/D	
	WA1536SXAAAA	A1536SN - SYx527 H.V. channels -3 kV 1 mA - SHV Conn. common floating (24 ch 10TE wide)	D	
	WA1536SXMAAA	A1536SM - SYx527 H.V. channels (12ch +3kV 1mA, 12ch -3kV 1mA) - SHV Conn. common floating (10TE)	D	
	WA1536SXPAAA	A1536SP - SYx527 H.V. channels +3 kV 1 mA - SHV Conn. common floating (24 ch 10TE wide)	D	
	WA1536VXAAAA	A1536VN - SYx527 H.V. channels -3 kV 800µA Multipin Conn. common floating (32 ch)	S	
	WA1536VXPAAA	A1536VP - SYx527 H.V. channels +3 kV 800µA Multipin Conn. common floating (32 ch)	S	
	WA1536XAAAAA	A1536N - SYx527 H.V. channels -3 kV 1 mA - Multipin Conn. common floating (32 ch)	S	
	WA1536XPAAAA	A1536P - SYx527 H.V. channels +3 kV 1 mA - Multipin Conn. common floating (32 ch)	S	
AG536	WAG536DXAAAA	AG536DN - SYx527 H.V. channels -3 kV 1 mA - SHV Conn. common ground (12 ch)	S	
	WAG536DXMAAA	AG536DM - SYx527 H.V. channels (6ch +3kV 1mA, 6ch -3kV 1mA) - SHV Conn. common ground	S	
	WAG536DXPAAA	AG536DP - SYx527 H.V. channels +3 kV 1 mA - SHV Conn. common ground (12 ch)	S	
	WAG536LXAAAA	AG536LN - SYx527 H.V. channels -3 kV 1 mA - Multipin Conn. common ground (24 ch)	S	
	WAG536LXPAAA	AG536LP - SYx527 H.V. channels +3 kV 1 mA - Multipin Conn. common ground (24 ch)	S	
	WAG536SVXAAA	AG536SVN - SYx527 H.V. channels -3 kV 800µA - SHV Conn. common ground (24 ch 10TE wide)	D	
	WAG536SVXPAA	AG536SVP - SYx527 H.V. channels +3 kV 800µA - SHV Conn. common ground (24 ch 10TE wide)	D	
	WAG536SXAAAA	AG536SN - SYx527 H.V. channels -3 kV 1 mA - SHV Conn. common ground (24 ch 10TE wide)	D	
	WAG536SXMAAA	AG536SM - SYx527 H.V. channels (12ch +3kV 1mA, 12ch -3kV 1mA) - SHV Conn. common ground (10TE)	D	
	WAG536SXPAAA	AG536SP - SYx527 H.V. channels +3 kV 1 mA - SHV Conn. common ground (24 ch 10TE wide)	D	
	WAG536VXAAAA	AG536VN - SYx527 H.V. channels -3 kV 800µA - Multipin Conn. common ground (32 ch)	S	
	WAG536VXPAAA	AG536VP - SYx527 H.V. channels +3 kV 800µA - Multipin Conn. common ground (32 ch)	S	
	WAG536XAAAAA	AG536N - SYx527 H.V. channels -3 kV 1 mA - Multipin Conn. common ground (32 ch)	S	
	WAG536XPAAAA	AG536P - SYx527 H.V. channels +3 kV 1 mA - Multipin Conn. common ground (32 ch)	S	
	A1821	WA1821NAAAAA	A1821N - SYx527 H.V. channels -3 kV 200/20 µA(20/2nA res.) - SHV Conn. (12 ch)	S
		WA1821PAAAAA	A1821P - SYx527 H.V. channels +3 kV 200/20 µA(20/2nA res.) - SHV Conn. (12 ch)	S
A1821H	WA1821HAAAAA	A1821HP - SYx527 H.V. channels +3 kV 200/10 µA(20/1nA res.) - SHV Conn. (12 ch)	S	
	WA1821HNAAAAA	A1821HN - SYx527 H.V. channels -3 kV 200/10 µA(20/1nA res.) - SHV Conn. (12 ch)	S	
A1833	WA1833NAAAAA	A1833N - SYx527 H.V. channels -3/4 kV 3/2 mA/200µA - SHV Conn. (12 ch)	S	
	WA1833PAAAAA	A1833P - SYx527 H.V. channels +3/4 kV 3/2 mA/200µA - SHV Conn. (12 ch)	S	
AP932	WAP932XAAAAA	AP932N - SYx527 H.V. channel -3 kV 30 mA - SHV Conn. individual floating (1 ch)	S	
	WAP932XPAAAA	AP932P - SYx527 H.V. channel +3 kV 30 mA - SHV Conn. individual floating (1 ch)	S	

Ordering Options - continued

S = Single width (5 TE wide)
D = Double width (10 TE wide)

Model	Code	Description	S/D	Model	Code	Description	S/D	
A1535	WA1535DXAAAA	A1535DN - SYx527 H.V. channels -3.5 kV 3 mA (8W) - SHV Conn. common floating (12 ch)	S		WAG7030TNXA3	AG7030TN - SYx527 H.V. channels -3 kV 1 mA (1.5 W) - Multipin Conn. common ground (36 ch)	S	
	WA1535DXMAAA	A1535DM - SYx527 H.V. channels (6ch +3.5kV 3mA, 6ch -3.5kV 3mA, 8W) - SHV Conn. common floating	S		WAG7030TPXA3	AG7030TP - SYx527 H.V. channels +3 kV 1 mA (1.5 W) - Multipin Conn. common ground (36 ch)	S	
	WA1535DXPAAA	A1535DP - SYx527 H.V. channels +3.5 kV 3 mA (8W) - SHV Conn. common floating (12 ch)	S		WAG7030LNXA2	AG7030LN - SYx527 H.V. channels -3 kV 1 mA (1.5 W) - Multipin Conn. common ground (24 ch)	S	
	WA1535SMXAAA	A1535SM - SYx527 H.V. channels (12ch +3.5kV 3mA, 12ch -3.5kV 3mA, 8W) - SHV common floating (10TE)	D		WAG7030LPXA2	AG7030LP - SYx527 H.V. channels +3 kV 1 mA (1.5 W) - Multipin Conn. common ground (24 ch)	S	
	WA1535SXAAAA	A1535SN - SYx527 H.V. channels -3.5 kV 3 mA (8W) - SHV Conn. common floating (24 ch 10TE wide)	D		WAG7030SNXA2	AG7030SN - SYx527 H.V. channels -3 kV 1 mA (1.5 W) - SHV Conn. common ground (24 ch 10TE wide)	D	
	WA1535SXPAAA	A1535SP - SYx527 H.V. channels +3.5 kV 3 mA (8W) - SHV Conn. common floating (24 ch 10TE wide)	D		WAG7030SPXA2	AG7030SP - SYx527 H.V. channels +3 kV 1 mA (1.5 W) - SHV Conn. common ground (24 ch 10TE wide)	D	
	WA1535XAAAAA	A1535N - SYx527 H.V. channels -3.5 kV 3 mA (8W) - Multipin Conn. common floating (24 ch)	S		WAG7030DNXA1	AG7030DN - SYx527 H.V. channels -3 kV 1 mA (1.5 W) - SHV Conn. common ground (12 ch)	S	
	WA1535XPAAAA	A1535P - SYx527 H.V. channels +3.5 kV 3 mA (8W) - Multipin Conn. common floating (24 ch)	S		WAG7030DPXA1	AG7030DP - SYx527 H.V. channels +3 kV 1 mA (1.5 W) - SHV Conn. common ground (12 ch)	S	
AG535	WAG535DXAAAA	AG535DN - SYx527 H.V. channels -3.5 kV 3 mA (6W) - SHV Conn. common ground (12 ch)	S	A1515	WA1515XAAAAA	A1515 - 16 Channel Floating 1kV, 0.1/1 mA Board	S	
	WAG535DXMAAA	AG535DM - SYx527 H.V. channels (6ch +3.5kV 3mA, 6ch -3.5kV 3mA, 6W) - SHV Conn. common ground	S		WA1515TGXAAA	A1515TG - 14 Channel Floating 1kV, 0.1/1 mA Board for Triple GEM detectors	S	
	WAG535DXPAAA	AG535DP - SYx527 H.V. channels +3.5 kV 3 mA (6W) - SHV Conn. common ground (12 ch)	S		WA1515QGXAAA	A1515QG - 16 Channel Floating 1kV, 0.1/1 mA Board for Quadruple GEM detectors	S	
	WAG535SMXAAA	AG535SM - SYx527 H.V. channels (12ch +3.5kV 3mA, 12ch -3.5kV 3mA, 6W) - SHV common ground (10TE)	D					
	WAG535SXAAAA	AG535SN - SYx527 H.V. channels -3.5 kV 3 mA (6W) - SHV Conn. common ground (24 ch 10TE wide)	D					
	WAG535SXPAAA	AG535SP - SYx527 H.V. channels +3.5 kV 3 mA (6W) - SHV Conn. common ground (24 ch 10TE wide)	D					
	WAG535XAAAAA	AG535N - SYx527 H.V. channels -3.5 kV 3 mA (6W) - Multipin Conn. common ground (24 ch)	S					
	WAG535XPAAAA	AG535P - SYx527 H.V. channels +3.5 kV 3 mA (6W) - Multipin Conn. common ground (24 ch)	S					
A7236	WA7236NXAAA3	A7236N - SYx527 H.V. channels -3.5kV 1.5mA (4W) - Multipin Conn. common floating (32 ch)	S					
	WA7236PXA3	A7236P - SYx527 H.V. channels +3.5kV 1.5mA (4W) - Multipin Conn. common floating (32 ch)	S					
AG7236	WAG7236NXAA3	AG7236N - SYx527 H.V. channels -3.5kV 1.5mA (4W) - Multipin Conn. common ground (32 ch)	S					
	WAG7236PXA3	AG7236P - SYx527 H.V. channels +3.5kV 1.5mA (4W) - Multipin Conn. common ground (32 ch)	S					
A7435	WA7435NXAAA2	A7435N - SYx527 H.V. channels -3.5kV 3.5mA (9W) - Multipin Conn. common floating (24 ch)	S					
	WA7435PXA2	A7435P - SYx527 H.V. channels +3.5kV 3.5mA (9W) - Multipin Conn. common floating (24 ch)	S					
AG7435	WAG7435NXAA2	AG7435N - SYx527 H.V. channels -3.5kV 3.5mA (9W) - Multipin Conn. common ground (24 ch)	S					
	WAG7435PXA2	AG7435P - SYx527 H.V. channels +3.5kV 3.5mA (9W) - Multipin Conn. common ground (24 ch)	S					
A7030	WA7030NXAAA4	A7030N - SYx527 H.V. channels -3 kV 1 mA (1.5 W) - Multipin Conn. common floating (48 ch)	S					
	WA7030PXA4	A7030P - SYx527 H.V. channels +3 kV 1 mA (1.5 W) - Multipin Conn. common floating (48 ch)	S					
	WA7030TNXA3	A7030TN - SYx527 H.V. channels -3 kV 1 mA (1.5 W) - Multipin Conn. common floating (36 ch)	S					
	WA7030TPXA3	A7030TP - SYx527 H.V. channels +3 kV 1 mA (1.5 W) - Multipin Conn. common floating (36 ch)	S					
	WA7030LNXA2	A7030LN - SYx527 H.V. channels -3 kV 1 mA (1.5 W) - Multipin Conn. common floating (24 ch)	S					
	WA7030LPXA2	A7030LP - SYx527 H.V. channels +3 kV 1 mA (1.5 W) - Multipin Conn. common floating (24 ch)	S					
	WA7030SNXA2	A7030SN - SYx527 H.V. channels -3 kV 1 mA (1.5 W) - SHV Conn. common floating (24 ch 10TE wide)	D					
	WA7030SPXA2	A7030SP - SYx527 H.V. channels +3 kV 1 mA (1.5 W) - SHV Conn. common floating (24 ch 10TE wide)	D					
	WA7030DNXA1	A7030DN - SYx527 H.V. channels -3 kV 1 mA (1.5 W) - SHV Conn. common floating (12 ch)	S					
	WA7030DPXA1	A7030DP - SYx527 H.V. channels +3 kV 1 mA (1.5 W) - SHV Conn. common floating (12 ch)	S					
	WA7030NXAAA4	AG7030N - SYx527 H.V. channels -3 kV 1 mA (1.5 W) - Multipin Conn. common ground (48 ch)	S					
	WA7030PXA4	AG7030P - SYx527 H.V. channels +3 kV 1 mA (1.5 W) - Multipin Conn. common ground (48 ch)	S					

NEW

A7030 - AG7030

General Purpose High Density Family

Need High Voltage but your budget is limited? Don't settle for a distributor board when you can have fully independent channel control!



Features

- 12/24/36/48 independently controllable HV channels
- 0 ÷ 3 kV output voltage
- 1 mA maximum output current (1.5 W max output power per channel)
- 2 models available:
 - AG7030 (Common Ground)
 - A7030 (Common Floating Return)
- Radial 52 pin or SHV coaxial connectors
- Available with positive or negative polarity
- 5 mV voltage monitor resolution
- 2 nA current monitor resolution
- Low Ripple
- Independently programmable for each channel:
 - Output voltage (50 mV resolution)
 - Current limit (20 nA resolution)
 - Ramp up/down (1 ÷ 500 V/s)
 - TRIP parameter

Overview

This new line of power supplies offers you all the safety, performance and control of a completely independent channel technology at the cost effective price of a distributor! You will never have to compromise again! The A7030/AG7030 line provides 48,32,24 or 12 independent High Voltage channels available with either positive or negative polarity. This family of HV boards is fully compatible with the CAEN Universal Multichannel Power Supply Systems (SY1527, SY2527, SY4527, SY5527). CAEN provides 2 different models with different channel grounding: AG7030 (Common Ground) and A7030 (Common Floating Return). AG7030 and A7030 are supplied in different versions equipped with SHV or with Radial Multipin connectors. The output voltage range is 0 ÷ 3 kV, with 50 mV monitor resolution. The maximum output current is 1 mA (1.5 W max. output power per channel), with 2 nA monitor resolution.

In the following tables all the boards belonging to the family are listed together with an overview of the relevant parameters and of all the available Ordering Options.

Model Specification

Model	Max Output V (kV)	Max Output I (mA)	Vset Resolution (mV)	Imon Resolution (nA)	Ripple Typ. (mVpp)	Max Power per Channel (W)	# of channels
A7030/AG7030	3	1	50	2	< 5	1.5	12/24/36/48

Ordering Options - Mod A7030

S = Single width (5 TE wide)
D = Double width (10 TE wide)

Code	Description	S/D
WA7030NXAAA4	A7030N - SYx527 H.V. channels -3 kV 1 mA (1.5 W) – Multipin Conn. common floating (48 ch)	S
WA7030PXAAA4	A7030P - SYx527 H.V. channels +3 kV 1 mA (1.5 W) – Multipin Conn. common floating (48 ch)	S
WA7030TNXAA3	A7030TN - SYx527 H.V. channels -3 kV 1 mA (1.5 W) – Multipin Conn. common floating (36 ch)	S
WA7030TPXAA3	A7030TP - SYx527 H.V. channels +3 kV 1 mA (1.5 W) – Multipin Conn. common floating (36 ch)	S
WA7030LNXAA2	A7030LN - SYx527 H.V. channels -3 kV 1 mA (1.5 W) – Multipin Conn. common floating (24 ch)	S
WA7030LPXAA2	A7030LP - SYx527 H.V. channels +3 kV 1 mA (1.5 W) – Multipin Conn. common floating (24 ch)	S
WA7030SNXAA2	A7030SN - SYx527 H.V. channels -3 kV 1 mA (1.5 W) – SHV Conn. common floating (24 ch 10TE wide)	D
WA7030SPXAA2	A7030SP - SYx527 H.V. channels +3 kV 1 mA (1.5 W) – SHV Conn. common floating (24 ch 10TE wide)	D
WA7030DNXAA1	A7030DN - SYx527 H.V. channels -3 kV 1 mA (1.5 W) – SHV Conn. common floating (12 ch)	S
WA7030DPXAA1	A7030DP - SYx527 H.V. channels +3 kV 1 mA (1.5 W) – SHV Conn. common floating (12 ch)	S

Ordering Options - Mod AG7030

S = Single width (5 TE wide)
D = Double width (10 TE wide)

Code	Description	S/D
WAG7030NXAA4	AG7030N - SYx527 H.V. channels -3 kV 1 mA (1.5 W) – Multipin Conn. common ground (48 ch)	S
WAG7030PXAA4	AG7030P - SYx527 H.V. channels +3 kV 1 mA (1.5 W) – Multipin Conn. common ground (48 ch)	S
WAG7030TNXA3	AG7030TN - SYx527 H.V. channels -3 kV 1 mA (1.5 W) – Multipin Conn. common ground (36 ch)	S
WAG7030TPXA3	AG7030TP - SYx527 H.V. channels +3 kV 1 mA (1.5 W) – Multipin Conn. common ground (36 ch)	S
WAG7030LNXA2	AG7030LN - SYx527 H.V. channels -3 kV 1 mA (1.5 W) – Multipin Conn. common ground (24 ch)	S
WAG7030LPXA2	AG7030LP - SYx527 H.V. channels +3 kV 1 mA (1.5 W) – Multipin Conn. common ground (24 ch)	S
WAG7030SNXA2	AG7030SN - SYx527 H.V. channels -3 kV 1 mA (1.5 W) – SHV Conn. common ground (24 ch 10TE wide)	D
WAG7030SPXA2	AG7030SP - SYx527 H.V. channels +3 kV 1 mA (1.5 W) – SHV Conn. common ground (24 ch 10TE wide)	D
WAG7030DNXA1	AG7030DN - SYx527 H.V. channels -3 kV 1 mA (1.5 W) – SHV Conn. common ground (12 ch)	S
WAG7030DPXA1	AG7030DP - SYx527 H.V. channels +3 kV 1 mA (1.5 W) – SHV Conn. common ground (12 ch)	S

A1515 - A1515TG - A1515QG

Solution For Gas Electron Multiplier Detectors

NEW

The ultimate solution for your multi-layered GEM detectors. All detector features under your control

Overview

The power supplies of the A1515 family house 14 or 16 independent, fully floating, High Voltage channels which are perfectly suited for Triple and Quadruple GEM Detectors. All versions are equipped with Radial Multipin connectors. The channels have floating return, independent one from another, insulated up to 5 kV. The output voltage range is $0 \div 1$ kV, with 20 mV set and monitor resolution. Maximum output current is 1 mA. The output channels offer dual current ranges (software selectable):

- High Power: $0 \div 1$ mA, (I_{mon} resolution: 1 nA)
- High resolution: $0 \div 100$ μ A, (I_{mon} resolution: 100 pA)

The boards are provided with both current and voltage protections. If overcurrent occurs, the relevant channel can be programmed either to turn off after a programmable trip time or to remain on and to provide the maximum allowed current. This particular feature allows the module to perform as a current generator. Channels can be enabled or disabled through the Interlock logic. The HV ramp-up and ramp-down rates may be selected, for each channel, in the $1 \div 100$ V/s range (1 V/s step).

Two special versions of the board (A1515TG/A1515QG) have been designed specifically for Gas Electron Multiplier (GEM) detectors. These boards have the channels internally stacked in order to power up 2 independent TripleGEM/QuadrupleGEM chambers. This configuration will help to prevent potential issues related to detector discharge and avalanche effects. This feature also provides the benefit of allowing the user to easily tune voltages for each detector layer. A CAEN 4527 mainframe equipped with 16 A1515TG/A1515QG boards may power up to 32 Detectors.

In the following tables all the boards belonging to the family are listed together with an overview of the relevant parameters and of all the available Ordering Options.

Model Compare

Model	Max Output V (kV)	Max Output I (mA)	Vset Resolution (mV)	I _{mon} Resolution (nA)	Ripple Typ. (mVpp)	Max Power per Channel (W)	# of channels
A1515TG	1	1	20	1/0.1	< 10 (CM) < 5 (DM)	0.8	14
A1515QG	1	1	20	1/0.1	< 10 (CM) < 5 (DM)	0.8	16
A1515	1	1	20	1/0.1	< 10 (CM) < 5 (DM)	0.8	16

Features

- 14/16 independently controllable HV channels
- Individual Full Floating Channel (insulated up to 5 kV)
- Designed specifically for GEM detectors
- Output channels grouped into 2 Complex channels
- Radial 52 pin connector
- $0 \div 1$ kV output voltage
- Dual range current:
 - High Power: $0 \div 1$ mA, (I_{mon} resolution: 1 nA)
 - High resolution: $0 \div 100$ μ A, (I_{mon} resolution: 100 pA)
- Max output power: 0.8 W per channel
- Programmable TRIP parameter (Complex channel setting)
- Current generator operation in Overcurrent condition
- Voltage ripple < 10 mVpp
- Dedicated accessories available:
 - A1015 - 16 Floating Channel Multipin Radial to SHV connector Adapter
 - A1015G - 14/16 Stacked Channel Multipin Radial to SHV connector Adapter
 - A1015VM - Analog Voltage Monitor for A1515 Family

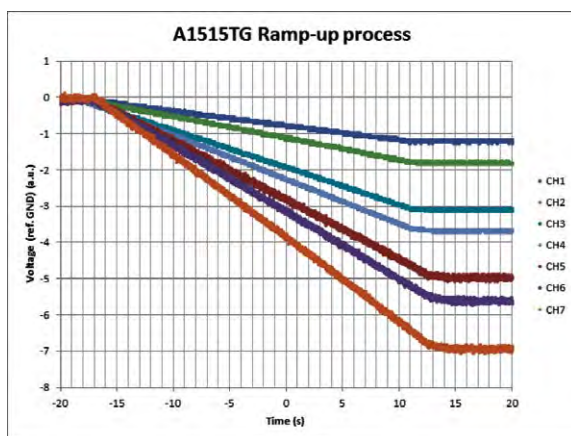

The high max current per channel feature designed into these boards is beneficial for managing the high segmentation of GEM detectors, as it will allow discrete detector layers to perform even in the event of a short. In addition the 2-quadrant 100 μ A low current range enables a 100 pA current monitoring resolution which allows the monitoring of ion backflow currents and real-time detector diagnostics. The above figures depict typical board power on/off behavior when connected to a triple GEM detector. The following accessories are available: Mate cable connector (Mod. A996) and relevant insertion/extraction tool (Mod. A995).

Ordering Options

S = Single width (5 TE wide)
D = Double width (10 TE wide)

Code	Description	S/D
WA1515XAAAA	A1515 - 16 Channel Floating 1kV, 0.1/1mA Board	S
WA1515TGXAAA	A1515TG - 14 Channel Floating 1kV, 0.1/1mA Board for Triple GEM detectors	S
WA1515QGXAAA	A1515QG - 16 Channel Floating 1kV, 0.1/1mA Board for Quadruple GEM detectors	S

NEW

A7236 - AG7236 - A7435 - AG7435

General Purpose High Power & High Resolution Power Supplies

No more compromise! High power and high resolution in a single board



In the following tables all the boards belonging to the family are listed together with an overview of the relevant parameters and of all the available Ordering Options.

Model Compare

Model	Max Output V (kV)	Max Output I (mA)	Vset Resolution (mV)	Imon Resolution (nA)	Ripple Typ. (mVpp)	Max Power per Channel (W)	# of channels
A7236/ AG7236	3.5	1.5	5	5/0.5	< 10	4	32
A7435/ AG7435	3.5	3.5	5	10/1	< 15	9	24

Ordering Options

S = Single width (5 TE wide)
D = Double width (10 TE wide)

Model	Code	Description	S/D
A7236	WA7236NXAAA3	A7236N - SYx527 H.V. channels -3.5kV 1.5mA (4W) - Multipin Conn. common floating (32 ch)	S
	WA7236PXAAA3	A7236P - SYx527 H.V. channels +3.5kV 1.5mA (4W) - Multipin Conn. common floating (32 ch)	S
AG7236	WAG7236NXAA3	AG7236N - SYx527 H.V. channels -3.5kV 1.5mA (4W) - Multipin Conn. common ground (32 ch)	S
	WAG7236PXAA3	AG7236P - SYx527 H.V. channels +3.5kV 1.5mA (4W) - Multipin Conn. common ground (32 ch)	S
A7435	WA7435NXAAA2	A7435N - SYx527 H.V. channels -3.5kV 3.5mA (9W) - Multipin Conn. common floating (24 ch)	S
	WA7435PXAAA2	A7435P - SYx527 H.V. channels +3.5kV 3.5mA (9W) - Multipin Conn. common floating (24 ch)	S
AG7435	WAG7435NXAA2	AG7435N - SYx527 H.V. channels -3.5kV 3.5mA (9W) - Multipin Conn. common ground (24 ch)	S
	WAG7435NXAA2	AG7435N - SYx527 H.V. channels -3.5kV 3.5mA (9W) - Multipin Conn. common ground (24 ch)	S

Features

- 24/32 independently controllable HV channels
- 0 ÷ 3.5 kV output voltage
- 4 models available:
 - AG7236/AG7435 (Common Ground)
 - A7236/A7435 (Common Floating Return)
- A7236/AG7236 Dual range current:
 - High Power: 0 ÷ 1.5 mA, (Imon resolution: 5 nA)
 - High resolution: 0 ÷ 150 µA, (Imon resolution: 500 pA)
- A7435/AG7435 Dual range current:
 - High Power: 0 ÷ 3.5 mA, (Imon resolution: 10 nA)
 - High resolution: 0 ÷ 350 µA, (Imon resolution: 1 nA)
- Radial 52 pin connector
- Available with positive or negative polarity
- 5 mV voltage monitor resolution
- Low Ripple
- Independently programmable for each channel:
 - Output voltage (5 mV resolution)
 - Current limit (5 nA resolution)
 - Ramp up/down (1 ÷ 500 V/s)
 - TRIP parameter

Overview

This new pair of CAEN general purpose power supplies will provide you with tremendous power and resolution performance at a cost effective price! You will never have to compromise again. The x7235 and x7236 house 24 and 32 channels, respectively. Both feature 52-pin Radial connectors, and both are available with either positive or negative polarity. They are fully compatible with all CAEN Universal Multichannel Power Supply Systems (SY1527, SY2527, SY4527, SY5527). The output voltage range is 0 ÷ 3.5 kV, with 5 mV of set and monitor resolution. These boards are available in two channel grounding configurations: Common Ground (AG7236/AG7235) for standard applications, and Common Floating Return (on-detector grounding) suitable for applications with more stringent noise requirements.

The output channels offer dual current ranges (software selectable).

- A7236/AG7236 Dual range current:
 - High Power: 0 ÷ 1.5 mA, (Imon resolution: 5 nA)
 - High resolution: 0 ÷ 150 µA, (Imon resolution: 500 pA)
- A7435/AG7435 Dual range current:
 - High Power: 0 ÷ 3.5 mA, (Imon resolution: 10 nA)
 - High resolution: 0 ÷ 350 µA, (Imon resolution: 1 nA)

The boards are provided with both current and voltage protections. If overcurrent occurs, the relevant channel can be programmed either to turn off after a programmable trip time or to remain on and to provide the maximum allowed current. This particular feature allows the module to perform as a current generator. Channels may be enabled or disabled via the Interlock logic. The HV ramp-up and ramp-down rates may be selected independently for each channel in the 1 ÷ 500 V/s range (1 V/s step).

up to 8 kV

A1550 - A15xxH - A1534

up to 8 kV High Voltage Family

Need to power a Wire Chamber, double gap RPC or Germanium detector? This is the family you need!

Features

- Up to 24 independently controllable HV channels
- Either Radial Multipin or SHV connector
- Available with either positive, negative or mixed polarity
- Up to 500/50 pA current set / monitor resolution
- Up to 100 mV voltage set / monitor resolution
- Programmable TRIP parameter
- Available boards with voltage ripple < 5 mVpp
- Current generator operation in overcurrent condition

Overview

This family of High Voltage power supplies includes single or double width boards housing up to 24 output channels. The boards are designed to provide voltage up to 8 kV, with up to 100 mV set and monitor resolution. The boards are provided with both current and voltage protections. If overcurrent occurs, the relevant channel can be programmed either to turn off after a programmable trip time or to remain on and to provide the maximum allowed current. This particular feature allows the module to perform as a current generator.

Channels may be enabled or disabled via the Interlock logic. The voltage ramp rates may be set independently for each channel. The customer can choose between different channel grounding. For this board category the best reduction of the voltage ripple can be obtained with the Common Floating Return configuration. Output channels are delivered through with either Radial Multipin or SHV connector.

In the following tables all the boards belonging to the family are listed together with an overview of the relevant parameters and of all the available Ordering Options.

Model Compare

Model	Max Output V (kV)	Max Output I (mA)	Vset Resolution (mV)	Imon Resolution (nA)	Ripple Typ. (mVpp)	Max Power per Channel (W)	# of channels
A1550	5	1	500	100	< 25	5	12/24
AG550	5	1	500	100	< 25	5	12/24
A1561H	6	0.02	100	0.05	< 5	0.12	12
A1560H	6	0.02	100	0.05	< 5	0.12	8/16
A1580H	8	0.02	200	0.05	< 5	0.16	8/16
A1534	8	0.2	500	20	< 50	1.6	6

Ordering Options

S = Single width (5 TE wide)
D = Double width (10 TE wide)

Model	Code	Description	S/D
A1550	WA1550DXAAAA	A1550DN - SYx527 H.V. channels -5 kV 1 mA - SHV Conn. common floating (12 ch)	S
	WA1550DXMAAA	A1550DM - SYx527 H.V. channels (6ch +5kV 1mA, 6ch -5kV 1mA) - SHV Conn. common floating	S
	WA1550DXPAAA	A1550DP - SYx527 H.V. channels +5 kV 1 mA - SHV Conn. common floating (12 ch)	S
	WA1550XPAAA	A1550SP - SYx527 H.V. channels +5 kV 1 mA - SHV Conn. common floating (24 ch 10TE wide)	D
	WA1550XAAAAA	A1550N - SYx527 H.V. channels -5 kV 1 mA - Multipin Conn. common floating (24 ch)	S
	WA1550XPAAAA	A1550P - SYx527 H.V. channels +5 kV 1 mA - Multipin Conn. common floating (24 ch)	S
A1560H	WA1560HDMEAA	A1560HDME - SYx527 H.V. (4ch +6kV 20µA, 4ch -6kV 20µA) (50pA res) Ind EN - SHV Conn. comm floating	S
	WA1560HDNEAA	A1560HDNE - SYx527 H.V. -6 kV 20 µA (50pA res) Individual Enable - SHV Conn. common floating (8 ch)	S
	WA1560HDPEAA	A1560HDPE - SYx527 H.V. +6 kV 20 µA (50pA res) Individual Enable - SHV Conn. common floating (8 ch)	S
	WA1560HNAAAA	A1560HNE - SYx527 H.V. -6 kV 20 µA (50pA res) Individual Enable - Multipin Conn. comm float (16 ch)	S
	WA1560HPAAAA	A1560HPE - SYx527 H.V. +6 kV 20 µA (50pA res) Individual Enable - Multipin Conn. comm float (16 ch)	S

Ordering Options - continued

S = Single width (5 TE wide)
D = Double width (10 TE wide)

Model	Code	Description	S/D
A1561H	WA1561HDMAAA	A1561HDM - SYx527 H.V. 6 ch channels +6 kV 20 μ A + 6 ch channels -6 kV 20 μ A - SHV - 50pA res.	S
	WA1561HDNAAA	A1561HDN - SYx527 H.V. channels -6 kV 20 μ A SHV (12 ch) - 50pA res.	S
	WA1561HDPAAA	A1561HDP - SYx527 H.V. channels +6 kV 20 μ A SHV (12 ch) - 50pA res.	S
A1580H	WA1580HDMEAA	A1580HDME - SYx527 H.V. (4ch +8kV 20 μ A, 4ch -8kV 20 μ A) (50pA res) Ind EN - SHV Conn. comm floating	S
	WA1580HDNEAA	A1580HDNE - SYx527 H.V. -8 kV 20 μ A (50pA res) Individual Enable - SHV Conn. common floating (8 ch)	S
	WA1580HDPEAA	A1580HDPE - SYx527 H.V. +8 kV 20 μ A (50pA res) Individual Enable - SHV Conn. common floating (8 ch)	S
	WA1580HNEAAA	A1580HNE - SYx527 H.V. -8 kV 20 μ A (50pA res) Individual Enable - Multipin Conn. comm float (16 ch)	S
	WA1580HPEAAA	A1580HPE - SYx527 H.V. +8 kV 20 μ A (50pA res) Individual Enable - Multipin Conn. comm float (16 ch)	S
A1534	WA1534XNAAAA	A1534N - SYx527 H.V. channels -8 kV 200 μ A Individual floating (6 ch)	S
	WA1534XPAAAA	A1534P - SYx527 H.V. channels +8 kV 200 μ A Individual floating (6 ch)	S

Single Range

Single Range High Precision

Featured Products

Model	Description
A1550	12/24 Channel 5 kV/1 mA Common Floating Return Boards
AG550	12/24 Channel 5 kV/1 mA Common Ground Boards
A1534	12 Channel 8 kV/200 μ A Individual Floating Channel Board

High Resolution	Common Floating Return	Common Ground	Individual Floating	Full Floating
	●			
		●		
			●	

Single Range

Single Range High Precision

Featured Products

Model	Description
A1561H	12 Channel 6 kV/20 μ A Common Floating Return Board

High Resolution	Common Floating Return	Common Ground	Individual Floating	Full Floating
●	●			

Single Range

Single Range High Precision

Featured Products

Model	Description
NEW A1560H - A1580H	High Precision Solution for Germanium Detectors

High Resolution	Common Floating Return	Common Ground	Individual Floating	Full Floating
●	●			

up to 8 kV

A1560H - A1580H

High Precision Solution for Germanium Detectors

NEW

Your precious germanium detector deserves extra safety and performance: introducing the new High Voltage with hardware individual enable and extremely high resolution

Overview

The A15x0H is a new CAEN family of HV Power Supply boards, available with either positive, negative or mixed polarity, compatible with the CAEN Universal Multichannel Power Supply System (SY1527, SY2527, SY3527, SY4527, SY5527). 8 and 16 channel version are available; all models feature individual channel enable.

The HV channels share a common floating return, which allows on-detector grounding reducing the noise level; the floating return is insulated from the crate earth up to ± 50 V (with 65 V hardware limit). The output voltage range is 0 \div 6 kV (A1560H) or 0 \div 8 kV (A1580H), with 10 mV monitor resolution.

The maximum output current is 20 μ A, with 50 pA monitor resolution. A1560H and A1580H are supplied in different versions equipped with SHV or with Radial Multipin connector. The boards are provided with both current and voltage protections. If overcurrent occurs, the relevant channel can be programmed either to turn off after a programmable trip time or to remain on and to provide the maximum allowed current. This particular feature allows the module to perform as a current generator. Channels may be enabled or disabled via the Interlock logic. The HV ramp-up and ramp-down rates may be selected independently for each channel in the 1 \div 500 V/s range (1 V/s step).

Features

- 8/16 independently controllable HV channels
- 2 models available:
 - A1560H: 0 \div 6 kV
 - A1580H: 0 \div 8 kV
- 20 μ A maximum output current
- Common floating return shared by all channels
- Channels with individual hardware enable
- Radial 52 pin or SHV coaxial connectors
- Available with positive, negative or mixed polarity
- 10 mV voltage monitor resolution
- 50 pA current monitor resolution
- Low Ripple
- Independently programmable for each channel:
 - Output voltage (100/200 mV resolution)
 - Current limit (500 pA resolution)
 - Ramp up/down (1 \div 500 V/s)
 - TRIP parameter
- Current generator operation in Overcurrent condition



Ordering Options

S = Single width (5 TE wide)
D = Double width (10 TE wide)

Model	Code	Description	S/D
A1560H	WA1560HNEAAA	A1560HNE - SYx527 H.V. -6 kV 20 μ A (50pA res) Individual Enable - Multipin Conn. comm float (16 ch)	S
	WA1560HPEAAA	A1560HPE - SYx527 H.V. +6 kV 20 μ A (50pA res) Individual Enable - Multipin Conn. comm float (16 ch)	S
	WA1560HDNEAA	A1560HDNE - SYx527 H.V. -6 kV 20 μ A (50pA res) Individual Enable - SHV Conn. common floating (8 ch)	S
	WA1560HDPEAA	A1560HDPE - SYx527 H.V. +6 kV 20 μ A (50pA res) Individual Enable - SHV Conn. common floating (8 ch)	S
	WA1560HDMEAA	A1560HDME - SYx527 H.V. (4ch +6kV 20 μ A, 4ch -6kV 20 μ A) (50pA res) Ind EN - SHV Conn. comm float	S
A1580H	WA1580HNEAAA	A1580HNE - SYx527 H.V. -8 kV 20 μ A (50pA res) Individual Enable - Multipin Conn. comm float (16 ch)	S
	WA1580HPEAAA	A1580HPE - SYx527 H.V. +8 kV 20 μ A (50pA res) Individual Enable - Multipin Conn. comm float (16 ch)	S
	WA1580HDNEAA	A1580HDNE - SYx527 H.V. -8 kV 20 μ A (50pA res) Individual Enable - SHV Conn. common floating (8 ch)	S
	WA1580HDPEAA	A1580HDPE - SYx527 H.V. +8 kV 20 μ A (50pA res) Individual Enable - SHV Conn. common floating (8 ch)	S
	WA1580HDMEAA	A1580HDME - SYx527 H.V. (4ch +8kV 20 μ A, 4ch -8kV 20 μ A) (50pA res) Ind EN - SHV Conn. comm float	S

In the following tables all the boards belonging to the family are listed together with an overview of the relevant parameters and of all the available Ordering Options.

Model Compare

Model	Max Output V (kV)	Max Output I (μ A)	Vset Resolution (mV)	I _{mon} Resolution (nA)	Ripple Typ. (mVpp)	Max Power per Channel (mW)	# of channels
A1560H	6	20	100	0.05	< 5	120	8/16
A1580H	8	20	200	0.05	< 5	160	8/16



A152x - A1590

up to 15 kV High Voltage Family

Overview

This family of High Voltage power supplies includes single or double width boards housing up to 16 output channels. The boards are designed to provide voltage up to 15 kV, with 0.2 or 1 V set and monitor resolution. The boards are provided with both current and voltage protections. If overcurrent occurs, the relevant channel can be programmed either to turn off after a programmable trip time or to remain on and to provide the maximum allowed current. This particular feature allows the module to perform as a current generator.

Channels may be enabled or disabled via the Interlock logic. The voltage ramp rates may be set independently for each channel. The customer can choose between different channel grounding. Individual Floating Channel allows the on-detector grounding providing the best reduction of the voltage ripple. Output channels are delivered through CPE or Multipin connectors.

If you work with Hybrid APD or application that need up to 15 kV, these are the boards for you

Features

- Up to 16 independently controllable HV channels
- CPE or Multipin connectors
- Available with either positive or negative polarity
- Up to 1 nA/100 pA current set / monitor resolution
- 1 or 0.2 V voltage set / monitor resolution
- Programmable TRIP parameter
- Available boards with voltage ripple < 10 mVpp
- Current generator operation in Overcurrent condition

Ordering Options

S = Single width (5 TE wide)
D = Double width (10 TE wide)

Model	Code	Description	S/D
A1590	WA1590NAAAAA	A1590N - SYx527 H.V. channels -9 kV 50 μ A - Multipin Conn. common float (16 ch)	D
	WA1590PAAAAA	A1590P - SYx527 H.V. channels +9 kV 50 μ A - Multipin Conn. common float (16 ch)	D
AG590	WAG590NAAAAA	AG590N - SYx527 H.V. channels -9 kV 50 μ A - Multipin Conn. common ground (16 ch)	D
	WAG590PAAAAA	AG590P - SYx527 H.V. channels +9 kV 50 μ A - Multipin Conn. common ground (16 ch)	D
A1523	WA1523XAAAAA	A1523N - SYx527 H.V. channels -12 kV 1 mA - CPE Conn. common floating (6 ch)	D
	WA1523XPAAAA	A1523P - SYx527 H.V. channels +12 kV 1 mA - CPE Conn. common floating (6 ch)	D
A1524	WA1524XAAAAA	A1524N - SYx527 H.V. channels -12 kV 100 μ A - CPE Conn. common floating (6 ch)	D
	WA1524XPAAAA	A1524P - SYx527 H.V. channels +12 kV 100 μ A - CPE Conn. common floating (6 ch)	D
AG523	WAG523XAAAAA	AG523N - SYx527 H.V. channels -12 kV 1 mA - CPE Conn. common ground (6 ch)	D
	WAG523XPAAAA	AG523P - SYx527 H.V. channels +12 kV 1 mA - CPE Conn. common ground (6 ch)	D
AG524	WAG524XAAAAA	AG524P - SYx527 H.V. channels +12 kV 100 μ A - CPE Conn. common ground (6 ch)	D
	WAG524XNAAAA	AG524N - SYx527 H.V. channels -12 kV 100 μ A - CPE Conn. common ground (6 ch)	D

In the following tables all the boards belonging to the family are listed together with an overview of the relevant parameters and of all the available Ordering Options.

Model Compare

Model	Max Output V (kV)	Max Output I (mA)	Vset Resolution (V)	I _{mon} Resolution (nA)	Ripple Typ. (mVpp)	Max Power per Channel (W)	# of channels
A1590	9	0.05	0.2	0.1	< 10	0.45	16
AG590	9	0.05	0.2	0.1	< 10	0.45	16
A1523	12	1	1	100	< 30	12	6
AG523	12	1	1	100	< 30	12	6
A1524	12	0.1	1	10	< 20	1.2	6
AG524	12	0.1	1	10	< 20	1.2	6
A1526	15	1/0.1	1	100/10	< 30	15	6

Single Range		Single Range High Precision	Featured Products	High Resolution	Common Floating Return	Common Ground	Individual Floating	Full Floating
Model	Description							
NEW	A1590	16 Channel 9 kV/50 μ A Common Floating Return Board			●			
NEW	AG590	16 Channel 9 kV/50 μ A Common Ground Board				●		
	A1523	6 Channel 12 kV/1 mA Common Floating Return Board			●			
	A1524	6 Channel 12 kV/100 μ A Common Floating Return Board			●			
	AG523	6 Channel 12 kV/1 mA Common Ground Board				●		
	AG524	6 Channel 12 kV/100 μ A Common Ground Board				●		

Single Range		Single Range High Precision	Featured Products	High Resolution	Common Floating Return	Common Ground	Individual Floating	Full Floating
Model	Description							
	A1526	6 Channel 15 kV, 1/0.1 mA Common Floating Return Board			●			

Single Range		Single Range High Precision	Featured Products	High Resolution	Common Floating Return	Common Ground	Individual Floating	Full Floating
Model	Description							
	A1526	Solution for Resistive Plate Chamber and other gas detectors			●			

A1526

Solution for Resistive Plate Chamber Detectors

A tailored solution for single gap RPC detector and other gas detectors



Features

- 6 independently controllable HV channels
- Available with either positive or negative polarity
- Dual Current Range
- 1 mA/100 μ A maximum output current
- Common floating return shared by all channels
- Channels with individual hardware enable
- Available with positive or negative polarity
- 1 V voltage monitor resolution
- 10/100 nA current monitor resolution
- Independently programmable for each channel:
 - Current limit (100 nA resolution)
 - Ramp up/down (1 \div 500 V/s)
 - TRIP parameter
- Current generator operation in Overcurrent condition

Overview

The A1526 is the CAEN board specifically designed for the single gap RPC detector. The channels share a common floating return, which allows on-detector grounding reducing the noise level. The output voltage can be programmed and monitored in the 0 \div 15 kV range with 1 V resolution.

The current full scale can be fixed via internal jumpers either at 100 μ A or at 1 mA. The boards are provided with both current and voltage protections. If overcurrent occurs, the relevant channel can be programmed either to turn off after a programmable trip time or to remain on and to provide the maximum allowed current. This particular feature allows the module to perform as a current generator.

The maximum output voltage can be fixed, through a potentiometer located on the front panel, at the same common value for all the board channels and this value can be read out via software. A global enable/disable connector allows to disable the channels when it is not terminated on 50 Ω .

The HV Ramp-Up and Ramp-Down rates may be selected independently for each channel in the 1 \div 500 V/s range (1 V/s step). The board features the CPE HV output connectors and the relevant coaxial cable connectors (Mod. A997) are also available.

In the following tables all the boards belonging to the family are listed together with an overview of the relevant parameters and of all the available Ordering Options.

Model Specifications

Model	Max Output V (kV)	Max Output I (mA)	Vset Resolution (V)	Imon Resolution (nA)	Ripple Typ. (mVpp)	Max Power per Channel (W)	# of channels
A1526	15	1/0.1	1	100/10	< 30	15	6

Ordering Options

S = Single width (5 TE wide)

D = Double width (10 TE wide)

Code	Description	S/D
WA1526XNAAAA	A1526N - SYx527 H.V. channels -15 kV 1/0.1 mA - CPE Conn. common floating (6 ch 10TE wide)	D
WA1526XA AAAA	A1526P - SYx527 H.V. channels +15 kV 1/0.1 mA - CPE Conn. common floating (6 ch 10TE wide)	D



A1588

Bipolar High Voltage Family

Overview

The A1588 board contains 8 independent channels providing High Voltage through SHV connectors; it is compatible with the CAEN Universal Multichannel Power Supply System (SY1527, SY2527, SY3527, SY4527, SY5527).

All channels are differential and can operate in the so called four-quadrant regimes supplying or operating as resistive load. It can provide, with an excellent long term output stability, a maximum voltage of ± 2 kV (with 100 mV setting resolution) and a maximum current of ± 500 μ A. Moreover, the channels share a common floating return, which allows on-detector grounding reducing the noise level; the floating return is insulated from the crate earth up to ± 50 V (with a 65 V hardware limit).

The board is provided with both current and voltage protections.

The maximum output voltage can be set through a potentiometer to a value which is common to all channels and can be read out via software. Channels may be enabled or disabled via the Interlock logic. The HV ramp-up and ramp-down rates may be selected independently for each channel in the $1 \div 500$ V/s range (1 V/s step).

4-Quadrant power supply for industrial and accelerator related applications

Features

- Four-quadrant bipolar power supply
- ± 2 kV @ ± 0.5 mA output ratings
- Common floating return
- SHV connectors
- Voltage ripple of < 10 mVpp
- Internal Hardware protections
- Excellent long-term output stability
- External interlocks (active + passive)

In the following tables all the boards belonging to the family are listed together with an overview of the relevant parameters and of all the available Ordering Options.

Ordering Options

S = Single width (5 TE wide)
D = Double width (10 TE wide)

Code	Description	S/D
WA1588XAAAAA	A1588 - SYx527 4 Quadrant Bipolar 8 HV Ch's ± 2 kV/500 μ A - SHV Comm.	S

Model Specifications

Model	Max Output V (kV)	Max Output I (mA)	Vset Resolution (mV)	I _{mon} Resolution (nA)	Ripple Typ. (mVpp)	Max Power per Channel (W)	# of channels
A1588	2	0.5	100	100	< 10	1	8

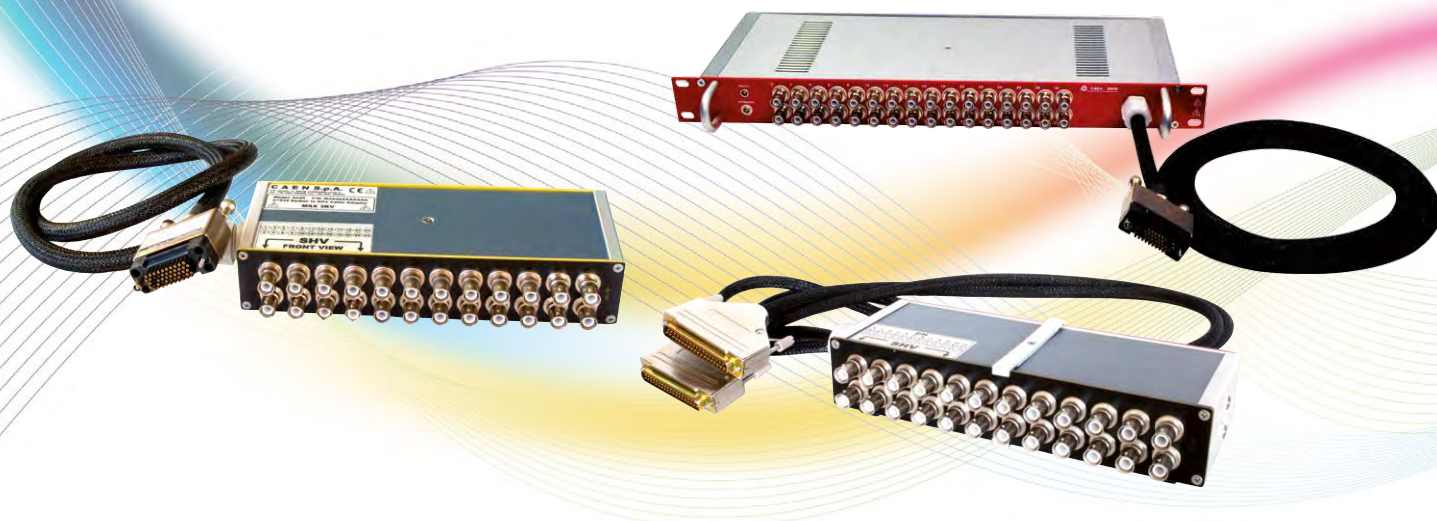

A1015x - A64x - R64x

HV Adapters (DB37 and Radial to SHV cable)

Overview

A1015x – A64x – R64x is a family of cable adapter that allows to adapt the high density SY boards connectors (DB37 and Radial) to the SHV one. The adapters belonging to this family forward the INTERLOCK and SHIELD connections through LEMO connectors as well. Available in desktop and rack form factor.

The A1015VM is not an adapter but an analog voltage monitor for A1515/A1515TG/A1515QG boards. It allows to monitor the voltage level for the triple or quadrupole GEM (the channels are internally stacked). The voltages can be monitored in two ways:

- in absolute value: checking the GEM or Transfer voltage with respect to the mass reference
- in differential value: checking the voltage level on each GEM or Transfer

In the following tables all the boards belonging to the family are listed together with an overview of the relevant parameters and of all the available Ordering Options.

Model	Channels	From	To	Max V.	Boards	Form Factor
A646	12	DB37	SHV	500 V	Up to 500 V family	Desktop
A647	24	Multipin	SHV	8 kV	Up to 8 kV family	Desktop
A648	48	Multipin	SHV	3 kV	Up to 4 kV family	Desktop
A649	32	Multipin	SHV	3 kV	Up to 4 kV family	Desktop
A649B	32	Multipin	SHV	8 kV	Up to 8 kV family	Desktop
R647	24	Multipin	SHV	8 kV	Up to 8 kV family	19" Rack
R648	48	Multipin	SHV	3 kV	Up to 4 kV family	19" Rack
R649B	32	Multipin	SHV	8 kV	Up to 8 kV family	19" Rack
R649	32	Multipin	SHV	3 kV	Up to 4 kV family	19" Rack
A1015	16	Multipin	SHV	5 kV	A1515	Desktop
A1015G	14/16	Multipin	SHV	5 kV	A1515TG/A1515QG	Desktop
A1015VM	-	-	-	-	A1515 Family	Desktop

The proper accessory for your lean setup

Features

- DB37 and Radial to SHV
- INTERLOCK and SHIELD connection provided

Ordering Options

Code	Description
WA646XAAAAA	A646 - DB37 to SHV Adapter for 12 ch HV Boards (Max: 500V - Desktop)
WA647XAAAAA	A647 - Multipin to SHV Adapter for 24 ch HV Boards (Max: 8kV - Desktop)
WA648XAAAAA	A648 - Multipin to SHV Adapter for 48 ch HV Boards (Max: 3kV - Desktop)
WA649XAAAAA	A649 - Multipin to SHV Adapter for 32 ch HV Boards (Max: 3kV - Desktop)
WA649BXAAAA	A649B - Multipin to SHV Adapter for 32 channel HV Boards (max 8kV)
WR647XAAAAA	R647 - Multipin to SHV Adapter for 24 ch HV Boards (Max: 8kV - 19" Rack)
WR648XAAAAA	R648 - Multipin to SHV Adapter for 48 ch HV Boards (Max: 3kV - 19" Rack)
WR649BXAAAA	R649B - 19" Multipin to SHV Adapter for 32 channel HV Boards (Max 8kV)
WR649XAAAAA	R649 - Multipin to SHV adapter for 32 ch HV Boards (Max: 3kV - 19" Rack)
WA1015XAAAA	A1015 - 16 Floating Channel Multipin Radial to SHV connector Adapter for A1515 board
WA1015GXAAAA	A1015G - 14/16 Stacked Channel Multipin Radial to SHV connector Adapter for A1515TG/A1515QG board
WA1015VMXAAA	A1015VM - Analog Voltage Monitor for A1515/A1515TG/A1515QG board



The VME boards are a fingerprint of CAEN production.

Initially born for data acquisition and front end applications, CAEN has recently introduced a new series of VME programmable HV boards, able to fit the same standard crate of DAQ systems. Thanks to the innovative GECO2020 Control Software and the multimaster capability of CAEN VME Bridges, it is possible to control independently the VME DAQ and the VME Power Supply Units.

NIM power supply is a trademark in CAEN products. Thanks to the latest designs CAEN offer a wider selection and an improved usability by the introduction of the GECO2020 software. The NIM Line includes also the NDT power supplies, which are hosted in a NIM module and can be plugged in NIM crates for power but have also the chance of Desktop operation thanks to a mains power supply cord.



VME High Voltage Power Supplies

NIM High Voltage Power Supplies

NIM Low Voltage Power Supplies

up to 6 kV

**Free Download
Software**

V65xx

VME High Voltage Power Supplies

Overview

The VME power supply family is a 6U modules family housing 6 independent High Voltage channels able to provide up to 6 kV and 3 mA. The units are available with either positive, negative or mixed polarity.

The channels share a common floating return, which allows on-detector grounding reducing the noise level. HV outputs are delivered through SHV connectors. The HV output ramp-up and ramp-down rates may be selected independently for each channel in the $1 \div 100$ V/s or $1 \div 500$ V/s range with 1 V/s steps. The modules feature high Iset/Imon resolution (up to 1 nA). A Zoom option is available for Imon, increasing resolution up to 100 pA. The modules fit into both VME/VME64 standard and V430 crates.

Functional parameters can be programmed and monitored via VMEbus. A complete set of software tools is available to control these units, from low level libraries to graphical application software. For detailed information see the Power Supply Control Software section.

Safety features include:

- **Overvoltage and Undervoltage** warning when the output voltage differs from the programmed value
- Programmable via trimmer VMAX and IMAX hardware protection limit
- **Overcurrent** detection: if a channel tries to draw a current larger than its programmed limit, it enters TRIP status, keeping the maximum allowed value for a programmable time (TRIP), before being switched off. If TRIP is set to "constant current mode", the channel behaves like a current generator.
- Channels can be enabled or disabled through the Global Interlock logic
- Channels individually enabled via front panel jumpers (passive or active mode available)

Available options:

- A6580 DC Input Power Equalizer
- Imon Zoom, increasing resolution up to 100 pA

CAEN HV Power Supplies now fit your rack in a flexible and reliable unit

Features

- 6 independent HV channels in 1 unit wide VME 6U module
- up to 6 kV and 3 mA output ranges
- Available with positive, negative or mixed polarity
- SHV coaxial output connectors
- Common floating return
- Low Ripple (Typ: from < 3 mVpp to < 15 mVpp)
- up to 1 nA Iset/Imon resolution (Optional Imon-Zoom: up to 100 pA)
- Status output
- Channel ON/Status LEDs
- Interlock logic for board enable
- Individual channel enable
- Optional A6580 DC Input Power Equalizer
- Module control via OPC Server

Control Software available: GECO2020 with user friendly GUI and CAEN HV Wrapper library for custom SW development. OPC Server also supported.



In the following tables all the boards belonging to the family are listed together with an overview of the relevant parameters and of all the available Ordering Options.

Model Compare

Model	Max Output V (V)	Max Output I (mA)	Vset Resolution (mV)	Imon Resolution (nA)	Ripple Typ. (mVpp)	Max Power per Channel (W)	# of channels
V6519	500	3	10	50 (5 with Imon Zoom)	< 3	1.5	6
V6533	4000	3	100	50 (5 with Imon Zoom)	< 12	9	6
V6534	6000	1	100	20 (2 with Imon Zoom)	< 15	6	6
V6521	6000	0.3	100	5 (0.5 with Imon Zoom)	< 3	1.8	6
V6521H	6000	0.02	100	1 (0.1 with Imon Zoom)	< 3	0.12	6

Ordering Options

Code	Description
WV6519MAAAAA	V6519M - 6 Channel VME Programmable High Voltage Power Supply (3 ch -500 V 3 mA, 3 ch +500 V 3 mA)
WV6519XAAAAA	V6519N - 6 Channel VME Programmable High Voltage Power Supply (-500 V 3 mA)
WV6519XPAAAA	V6519P - 6 Channel VME Programmable High Voltage Power Supply (+500 V 3 mA)
WV6533MAAAAA	V6533M - 6 Channel VME Programmable High Voltage Power Supply (3 ch -4 kV 3 mA, 3 ch +4 kV 3 mA, 9W)
WV6533XAAAAA	V6533N - 6 Channel VME Programmable High Voltage Power Supply (-4 kV 3 mA 9 W max.)
WV6533XPAAAA	V6533P - 6 Channel VME Programmable High Voltage Power Supply (+4 kV 3 mA 9 W max.)
WV6534MAAAAA	V6534M - 6 Channel VME Programmable High Voltage Power Supply (3 ch -6 kV 1 mA, 3 ch +6 kV 1 mA)
WV6534XAAAAA	V6534N - 6 Channel VME Programmable High Voltage Power Supply (-6 kV 1 mA)
WV6534XPAAAA	V6534P - 6 Channel VME Programmable High Voltage Power Supply (+6 kV 1 mA)
WV6521MAAAAA	V6521M - 6 Channel VME Programmable High Voltage Power Supply (3 ch -6 kV 300 μ A, 3 ch +6 kV 300 μ A)
WV6521XAAAAA	V6521N - 6 Channel VME Programmable High Voltage Power Supply (-6 kV 300 μ A)
WV6521XPAAAA	V6521P - 6 Channel VME Programmable High Voltage Power Supply (+6 kV 300 μ A)
WV6521HAAAAA	V6521HN - 6 Channel VME Programmable High Voltage Power Supply (-6 kV 20 μ A/1nA res)
WV6521HMAAAA	V6521HM - 6 Channel VME Programmable High Voltage Power Supply (3ch -6 kV 20 μ A, 3ch +6kV 20 μ A/1nA res)
WV6521HPAAAA	V6521HP - 6 Channel VME Programmable High Voltage Power Supply (+6 kV 20 μ A/1nA res)
WPER5065XX01	V65XX Customization - Imon Zoom x10
WA6580XAAAAA	A6580 - DC Power Input Equalizer for V65XX Family

DAQ
SystemHV
System

Thanks to the innovative GECO2020 Control Software and Multimaster Capability of CAEN VME Bridges, CAEN VME High Voltage Boards become a System. Now you can house your power supplies within the same standard crate of your DAQ... independently!



Easy Set-up via USB/Optical link thanks to
GECO2020 control software

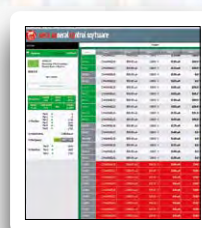

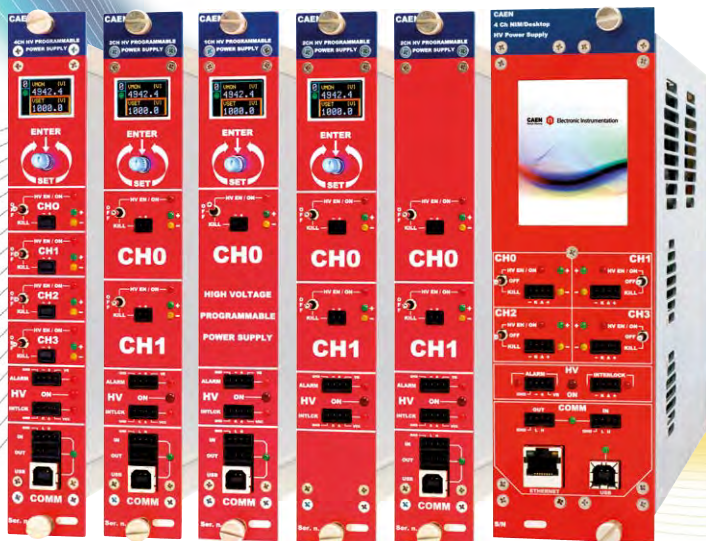

up to 8 kV
Reversible Polarity

Free Download
Software

NDT14xx - N14xxET - N14xx NIM High Voltage Power Supplies

Number of channels, polarity, connectivity, display and Vac plug: it's your choice!

Features

- 4/2/1 independent channels in 1U NIM module
- Channel polarity independently selectable
- SHV coaxial output connectors
- Common floating return
- Very Low Ripple
- Under/over-voltage alert, overcurrent and max. voltage protection
- Daisy-chain capability
- 2.8" color touch screen or OLED display
- Local and Remote control (USB 2.0/Ethernet)
- Optional selectable power requirement
- Interlock logic for board enable and Individual channel kill
- LabVIEW Driver available
- Software Tools for remote control
- 2U/Desktop (with 110-220 Vac) version available

Remember! Our NDT power supplies can work as a standalone unit like the classic desktop ones!



Control Software available: GECO2020 with user friendly GUI and CAEN HV Wrapper library for custom SW development. EPICS and LabVIEW also supported



Overview

The NIM power supply family provides a series of Independent High Voltage channels in 1U (N14xx) or 2U (NDT14xx, N14xxET) NIM module. N14xxET and NDT14xx families provides 4 channels, while N14xx are available in versions housing 4, 2 or 1 channels (N14xx, N14xA, N14xB). Each channel can provides up to 8 kV and 3 mA max output. The output polarity is independently selectable for each channel that features common floating return (common return insulated from the crate ground); HV outputs are delivered through SHV connectors.

The HV output ramp-up and ramp-down rates may be selected independently for each channel in the range $1 \div 50$ V/s or $1 \div 500$ V/s in 1 V/s steps. The modules feature high Iset/Imon resolution (up to 1 nA). Each unit is provided with Imon Zoom(*), this feature increase Imon resolution up to 50 pA. Power supply control can be performed either locally, assisted by a 2.8" color touch screen or OLED display or remotely, via Ethernet, USB, RS232, RS485, the latter allowing to build a daisy chain network of modules N14xx. For those module not featuring the Ethernet interface, it is also possible to setup a control via TCP/IP by the Smart Fan Unit of CAEN NIM8301 as shown in the next page figure.

The NDT modules can work either as a standard NIM module or a desktop power supply thanks to the 110-220 AC plug. A complete set of software tools is available to control these units, from low level libraries to graphical application software. For detailed information see the Power Supply Control Software section.

(* Imon Zoom is an option for N1419/A/B, N1470/A/B, N1471/A/B

Safety features include:

- **Overvoltage and Undervoltage** warning when the output voltage differs from the programmed value by more than 2% of set value (minimum 10 V).
- Programmable VMAX protection limit
- **Overcurrent** detection: if a channel tries to draw a current larger than its programmed limit, it enters TRIP status, keeping the maximum allowed value for a programmable time (TRIP), before being switched off. If TRIP is set to "constant current mode", the channel behaves like a current generator.
- Common Interlock logic for channels enable/disable and individual inputs signal for channel Kill function.

In the following tables all the boards belonging to the family are listed together with an overview of the relevant parameters and of all the available Ordering Options.

Single Channel Features Compare

Model	Max Output V (V)	Max Output I (mA)	Vset Resolution (mV)	Imon Resolution (nA)	Ripple Typ. (mVpp)	Ground	Max Power per Channel (W)
Nx1419x	±500	0.2	10	5 (0.5 with Imon zoom)	< 3	Common Floating Return	0.1
Nx1471Hx	±5500	0.02	100	1 (0.05 with Imon zoom)	< 5	Common Floating Return	0.1
Nx1471x	±5500	0.3	100	5 (0.5 with Imon zoom)	< 5	Common Floating Return	1.65
Nx1470x	±8000	3	200	50 (5 with Imon zoom)	< 5-15	Common Floating Return	9 (<3 kV) / 8 (>3 kV)

Family Type	Form Factor	N. of Channel	Remote Interface			Local Interface		Vac plug for Desktop operation	Version	Channel Type				
			Ethernet	USB 2.0	RS232/RS485	2.8" Touch Screen	Oled Display			±500 V 200 μA	±5.5 kV 20 μA	±5.5 kV 300 μA	±8 kV 3 mA (9W)	
NDT14xx	NIM 2U	4	*	*	-	*	-	*	NDT1419	*				
									NDT1471H		*			
									NDT1471			*		
									NDT1470				*	
N14xxET	NIM 2U	4	*	*	-	*	-	-	N1419ET	*				
									N1471HET		*			
									N1471ET			*		
									N1470ET				*	
N14xx	NIM 1U	4 / 2 / 1	-	*	*	-	*	-	N1419A/B	*				
									N1471H/A/B		*			
									N1471A/B			*		
		N1470A/B				*								
		2	-	-	-	-	*	-	-	N1470AL				*
										N1470AR				*

Module control can take place either locally, assisted by a Graphic colour display, or remotely, via USB (1) or RS485 (1). It is also controllable via TCP/IP (2) by the Smart Fan Unit of CAEN NIM 8301 crate:

Special versions available:

- 2U NIM module plug USB/Ethernet and touch screen display (N14xxET).
- 2U NIM module with 110 - 220 Vac plug USB/Ethernet and touch screen display for desktop operation (NDT14xx).

Available options:

- A1480 DC Input Power Equalizer.

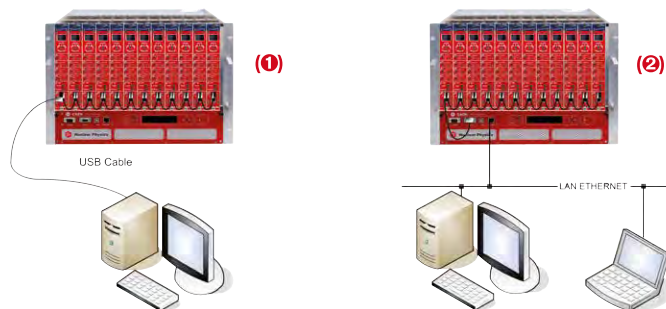
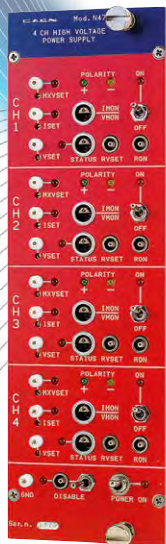

Figure 1: N14xx control can take place either locally (graphic colour display) or remotely via USB (1) or RS485 (1). It is also controllable via TCP/IP (2) through the Smart Fan Unit of CAEN NIM 8301 crate.

Ordering Options

Model	Code	Description
N1419	WN1419XAAAAA	N1419 - 4 Ch NIM Programmable HV Power Supply (±500V, 200μA, 5nA res.)
	WN1419AXAAAAA	N1419A - 2 Ch NIM Programmable HV Power Supply (±500V, 200μA, 5nA res.)
	WN1419BXAAAAA	N1419B - 1 Ch NIM Programmable HV Power Supply (±500V, 200μA, 5nA res.)
N1419ET	WN1419ETXAAA	N1419ET - 4 Channel 500V/200μA NIM HV Power Supply Module with Ethernet & 2.8" Touchscreen
NDT1419	WN1419AAAAA	NDT1419 - 4 Ch NIM/Desktop Programmable HV Power Supply (±500V, 200μA, 5nA res.)
N1470	WN1470X08AAC	N1470 - 4 Ch NIM Programmable HV Power Supply (±8kV, 3mA, 50nA res.)
	WN1470A08AAC	N1470A - 2 Ch NIM Programmable HV Power Supply (±8kV, 3mA, 50nA res.)
	WN1470B08AAC	N1470B - 1 Ch NIM Programmable HV Power Supply (±8kV, 3mA, 50nA res.)
	WN1470ALCLAA	N1470AL - 2 Ch NIM Low Cost Locally Programmable HV Power Supply (±8kV, 3mA, 50nA res.)
	WN1470ALCRAA	N1470AR - 2 Ch NIM Low Cost Remotely Programmable HV Power Supply (±8kV, 3mA, 50nA res.)
N1470ET	WN1470ETXAAA	N1470ET - 4 Channel 8kV/3mA (9W) NIM HV Power Supply Module with Ethernet & 2.8" Touchscreen
NDT1470	WN1470AAAAA	NDT1470 - 4 Ch NIM/Desktop Programmable HV Power Supply (±8kV, 3mA, 50nA res.)

Model	Code	Description
N1471	WN1471X05AAC	N1471 - 4 Ch NIM Programmable HV Power Supply (±5.5kV, 300μA, 5nA res.)
	WN1471A05AAC	N1471A - 2 Ch NIM Programmable HV Power Supply (±5.5kV, 300μA, 5nA res.)
	WN1471B05AAC	N1471B - 1 Ch NIM Programmable HV Power Supply (± 5.5kV, 300μA, 5nA res.)
N1471ET	WN1471ETXAAA	N1471ET - 4 Channel 5.5kV NIM HV Power Supply Module with Ethernet & 2.8" Touchscreen
NDT1471	WN1471AAAAA	NDT1471 - 4 Ch NIM/Desktop Programmable HV Power Supply (±5.5kV, 300μA, 5nA res.)
N1471H	WN1471HX05AC	N1471H - 4 Ch NIM Programmable High CurrentRes. HV Power Supply (±5.5kV, 20μA, 1nA res.)
	WN1471HA05AC	N1471HA - 2 Ch NIM Programmable High CurrentRes. HV Power Supply (±5.5kV, 20μA, 1nA res.)
	WN1471HB05AC	N1471HB - 1 Ch NIM Programmable High CurrentRes. HV Power Supply (±5.5kV, 20μA, 1nA res.)
N1471HET	WN1471HETXAA	N1471HET - 4 Channel 5.5kV NIM HV Power Supply High Accuracy Module with Ethernet & 2.8" TouchScreen
NDT1471H	WN1471HAAAA	NDT1471H - 4 Ch NIM/Desktop Programmable High CurrentRes. HV Power Supply (±5.5kV, 20μA, 1nA res.)
	WA1480XAAAAA	A1480 - DC Power Input Equalizer for N14XX Family and N1570
	WPERS0147001	N14XX Customization - Imon Zoom
	WPERS0147002	N14XX Customization - Internal Common Ground



N472

NIM High Voltage Power Supply

Features

- Two output ranges: ± 3 kV / 3 mA and ± 6 kV / 1 mA
- 4 channels in a double width unit
- Positive or negative polarity selectable for each channel
- Local or remote individual channel setting and monitoring
- Remote HV Enable via TTL common to all channels
- Hardware HV limit
- 110/220 Vac external power available

Overview

The N472 is a double width NIM unit housing 4 independent High Voltage channels.

The output voltages range from 0 to ± 3 kV / 3 mA, or up to ± 6 kV / 1 mA (max. output ripple of 30 mVpp at full load).

The output polarity is independently selectable for each channel.

All channels have individual settings and feature test points and connectors for the monitoring of voltages and currents. The setting of the output voltages can be done locally, via trimmers located on the front panel, or remotely, via analog signals.

The setting of the output maximum Voltage and Current limit can be done only locally via front panel trimmers. The channel polarity, overcurrent status and reaching of the VMAX limit are displayed on front panel LEDs.

The High Voltage enable can be set both locally, via front panel switch, and remotely, via an external TTL level. Each channel can be individually turned on, either locally or remotely.

The module is intrinsically safe: the High Voltage is present only on the SHV output connectors.

The module can be powered either by the NIM crate or with 110/220 Vac via a back panel Standard European connector.

In the following tables all the boards belonging to the family are listed together with an overview of the relevant parameters and of all the available Ordering Options.

Ordering Option

Code	Description
WN472XAAAAA	N472 - 4 Channel NIM High Voltage Power Supply (± 6 kV 1 mA, ± 3 kV 3 mA)

Model Specifications

Model	Max Output V (kV)	Max Output I (mA)	Vset Resolution	I _{mon} Resolution	Ripple Typ. (mVpp)	Max Power per Channel (W)	# of channels
N472	± 3 kV	3	± 1 %	± 2 %	< 30 (3 kV)	9	4
	± 6 kV	1			< 80 (6 kV)	6	

up to 15 kV
Reversible Polarity



Free Download
Software



N1570 NIM HV Power Supply with Ethernet and Touchscreen

NEW

Overview

The N1570 provides 2 independent High Voltage channels in a double width NIM mechanics. Each channel can provide a ± 15 kV max voltage, 1 mA max current and 10 W max power. The output polarity is independently selectable for each channel. Channels have common floating return (common return insulated from the crate ground); HV outputs are delivered through LEMO HV connectors. The HV output ramp-up and ramp-down rates may be selected independently for each channel in the range $1 \div 500$ V/s in 1 V/s steps.

The module features 20 nA Iset/Imon resolution. Zoom (x 10) for Imon increases resolution to 2 nA. Module control can take place either locally thanks to a 2.8" Touchscreen Graphic color LCD display with a completely redesigned user interface or remotely, via USB or Ethernet, taking advantage of the GEICO2020 Control Software.

Safety features include:

- **Overvoltage and Undervoltage** warning when the output voltage differs from the programmed value by more than 2% of set value (minimum 10 V).
- Programmable VMAX protection limit
- **Overcurrent** detection: if a channel tries to draw a current larger than its programmed limit, it enters TRIP status, keeping the maximum allowed value for a programmable time (TRIP), before being switched off. If TRIP is set to "constant current mode", the channel behaves like a current generator.
- Common Interlock logic for channels enable/disable and individual inputs signal for channel Kill function.

Available options:

- A1480 DC Input Power Equalizer.

Model Specifications

Model	Max Output V (kV)	Max Output I (mA)	Vset Resolution (mV)	Imon Resolution (mA)	Ripple Typ. (mVpp)	Max Power per Channel (W)	# of channels
N1570	± 15	1	500	20 (2 with Imon zoom)	TBD	10	2

Features

- 2 independent channels in 2U NIM module
- $0 \div 15$ kV output voltage
- 1 mA maximum output current (10 W max)
- Channel polarity independently selectable
- LEMO HV coaxial output connectors
- Common floating return
- Under/over-voltage alert, overcurrent and max. voltage protection
- Daisy-chain capability
- 2.8" color touch screen display
- Local and Remote control (USB 2.0/Ethernet)
- Optional selectable power requirement
- Interlock logic for board enable and Individual channel kill
- LabVIEW Driver available
- Software Tools for remote control
- Desktop and Rack versions available (coming soon)

Control Software available: GEICO2020 with user friendly GUI and CAEN HV Wrapper library for custom SW development. EPICS and LabVIEW also supported



In the following tables all the boards belonging to the family are listed together with an overview of the relevant parameters and of all the available Ordering Options.

Ordering Options

Code	Description
WN1570XAAAAA	N1570 - 2 Ch NIM Programmable HV Power Supply (± 15 kV, 1mA, 20nA res.)
WA1480XAAAAA	A1480 - DC Power Input Equalizer for N14XX Family and N1570



Quad NIM Power Distributor - N5424

NIM Low Voltage Power Supply

Overview

The N5424 is a 4-channel NIM power distribution and control module.

The individual voltage outputs (± 6 V, ± 12 V and ± 24 V) are protected by electronic fuses which automatically recover after short circuit. All six voltages are surveyed for each of the four outputs. The status is displayed by LEDs. The module also helps to check the correct voltage levels of a NIM-bin. If a NIM-bin without ± 24 V is used, the corresponding LEDs get off, and the voltage survey of those voltages is skipped.

Low-noise preamplifiers require DC power that is free of interference generated by other modules inserted in the bin. The mod. N5424 ensures this low-noise capability by filtering the power lines separately at each connector.

Features

- Single-width NIM module
- Four DB9 connectors with ± 6 V, ± 12 V, ± 24 V each
- Survey of all 6 voltages on each output
- Protection of all voltages by self-recovering electrical fuses
- Individually filtered outputs to ensure low noise operation
- Standard voltage output compatible to CAEN electronics and to many other manufacturers

Ordering Option

Code	Description
WN5424XAAAA	N5424 - Quad NIM Power Distributor for A1422 Preamplifier



Tired of powered crates and chassis? Try our new Desktop power supply solutions. Today even with Ethernet!

Is your rack missing of power supply solutions? The new CAEN power supply Rack line is here.

Introducing the new CAEN PCB form factor power supplies.

The new component for hardware developers & ideal for distributed solutions. Simply add the HV to your design without giving up high performances and the reliability of a remote control (analog or digital).



Desktop High Voltage Power Supplies

Desktop Low Voltage Power Supplies

Rack High Voltage Power Supplies

PCB High Voltage Power Supplies

up to 6 kV

**Free Download
Software**
**NEW**

DT55xxE Desktop High Voltage Power Supplies

Overview

The DT55xxE is a new CAEN Power Supply Family providing 4 independent High Voltage channels in a compact Desktop form factor. The units are available with either positive, negative or mixed polarity. High Voltage outputs are delivered through SHV connectors. DT55xxE units can be controlled, via USB or Ethernet, taking advantage of the new GECO2020 Control Software. EPICS and LabVIEW are also supported.

Different versions are available spanning from 500 V to 6 kV and from 20 μ A to 3 mA (4 W maximum), meeting the needs of a wide range of applications. A Zoom option is available for Imon. This feature enhances the current monitoring, increasing the resolution of a x10 factor (up to 10 pA). The HV output Ramp-Up and Ramp-Down rates can be independently for each channel in the range 1 \div 500 V/s in 1 V/s steps (1 \div 100 V/s for DT5519E).

Safety features include:

- **Overvoltage and Undervoltage** warning when the output voltage differs from the programmed value (0.5% of the set value, minimum 3 V)
- Programmable hardware VMAX protection limit
- **Overcurrent** detection: if a channel tries to draw a current larger than its programmed limit, it is signalled to be in "overcurrent" and is switched off. The High Voltage will drop to zero at a rate determined by the value of "Ramp-Down" for that channel.
- Common Interlock logic for channels enable/disable and individual input signal for channel Kill function.

Control Software available: GECO2020 with user friendly GUI and CAEN HV Wrapper library for custom SW development. EPICS and LabVIEW also supported per library for custom SW development.



The whole new Desktop Power Supply Family from CAEN. Quality and Usability redesigned for your laboratory

Features

- 4 independent HV channels in a compact desktop module
- up to 6 kV / 3 mA output ranges
- Available with positive, negative or mixed polarity
- SHV coaxial output connectors
- Very Low Ripple (Typ: from 3 mVpp to 15 mVpp)
- Under/overvoltage alert, overcurrent and max. voltage protection
- Status output Channel ON/Status LEDs
- Remote control via USB 2.0 and Ethernet
- Interlock logic for unit enable and individual channel kill

In the following tables all the boards belonging to the family are listed together with an overview of the relevant parameters and of all the available Ordering Options.

Model Compare

Model	Max Output V (kV)	Max Output I (mA)	Vset Resolution (mV)	Imon Resolution (nA)	Ripple Typ. (mVpp)	Max Power per Channel (W)	# of channels
DT5519E	500	3	10	10 (1 with Imon Zoom)	< 3	1.5	4
DT5533E	4000	3	100	10 (1 with Imon Zoom)	< 12	4	4
DT5534E	6000	1	100	5 (0.5 with Imon Zoom)	< 15	4	4
DT5521E	6000	0.3	100	1 (0.1 with Imon Zoom)	< 3	1.8	4
DT5521HE	6000	0.02	100	0.1 (0.01 with Imon Zoom)	< 3	0.12	4

Ordering Options

Code	Description
WDT5519EXNAA	DT5519EN - 4 Channel 500 V/3 mA Desktop HV Power Supply (USB/Ethernet) - Negative
WDT5519EXPAA	DT5519EP - 4 Channel 500 V/3 mA Desktop HV Power Supply (USB/Ethernet) - Positive
WDT5519EXMAA	DT5519EM - 4 Channel 500 V/3 mA Desktop HV Power Supply (USB/Ethernet) - Mixed
WDT5533EXNAA	DT5533EN - 4 Channel 4 kV/3 mA (4 W) Desktop HV Power Supply (USB/Ethernet) - Negative
WDT5533EXPAA	DT5533EP - 4 Channel 4 kV/3 mA (4 W) Desktop HV Power Supply (USB/Ethernet) - Positive
WDT5533EXMAA	DT5533EM - 4 Channel 4 kV/3 mA (4 W) Desktop HV Power Supply (USB/Ethernet) - Mixed
WDT5534EXNAA	DT5534EN - 4 Channel 6 kV/1 mA (4 W) Desktop HV Power Supply (USB/Ethernet) - Negative
WDT5534EXPAA	DT5534EP - 4 Channel 6 kV/1 mA (4 W) Desktop HV Power Supply (USB/Ethernet) - Positive
WDT5534EXMAA	DT5534EM - 4 Channel 6 kV/1 mA (4 W) Desktop HV Power Supply (USB/Ethernet) - Mixed
WDT5521EXNAA	DT5521EN - 4 Channel 6 kV/300 μ A Desktop HV Power Supply (USB/Ethernet) - Negative
WDT5521EXPAA	DT5521EP - 4 Channel 6 kV/300 μ A Desktop HV Power Supply (USB/Ethernet) - Positive
WDT5521EXMAA	DT5521EM - 4 Channel 6 kV/300 μ A Desktop HV Power Supply (USB/Ethernet) - Mixed
WDT5521HENAA	DT5521HE - 4 Channel 6 kV/20 μ A Desktop HV Power Supply (USB/Ethernet) - Negative
WDT5521HEPAA	DT5521HE - 4 Channel 6 kV/20 μ A Desktop HV Power Supply (USB/Ethernet) - Positive
WDT5521HEMAA	DT5521HE - 4 Channel 6 kV/20 μ A Desktop HV Power Supply (USB/Ethernet) - Mixed
WPERS0550001	DT55XX - Customization - Imon Zoom

Remember! Our NDT power supplies can work as a standalone unit like the classic desktop ones!



For more information, please have a look to the NIM power supplies section on this catalogue or on our website.

up to 8 kV
Reversible Polarity

Free Download
Software



Ethernet, USB & Touchscreen

NEW

DT14xxET

Desktop High Voltage Power Supplies

Overview

The DT14xxET is a CAEN Power Supply Family providing 4 independent High Voltage channels in a Desktop form factor. Each channel features an independently selectable polarity and common floating return (common return insulated from the chassis ground). High Voltage outputs are delivered through SHV connectors. DT14xxET units can be controlled either locally, thanks to a 2.8" touchscreen color LCD display with a complete user interface, or remotely, via USB or Ethernet, taking advantage of the new GECO2020 Control Software. EPICS and LabVIEW are supported. Different versions are available spanning from 500 V to 8 kV and from 20 μ A to 3 mA, meeting the needs of a wide range of applications. Each unit is provided with Imon Zoom. This feature enhances the current monitoring, increasing the resolution of a x10 or x20 factor according to the specific model.

The HV output Ramp-Up and Ramp-Down rates can be set independently for each channel in the range 1 ÷ 500 V/s in 1 V/s steps (1 ÷ 50 V/s for DT1419ET).

Safety features include:

- **Overvoltage and Undervoltage** warning when the output voltage differs from the programmed value (2% of the set value, minimum 10 V).
- Programmable hardware VMAX protection limit
- **Overcurrent** detection: when a channel attempts to exceed the programmed current limit, it signaled to be in "overcurrent" and enter in a TRIP status. The output voltage is varied to keep the current below the programmed limit for a programmable TRIP time, then the channel is switched off. If TRIP is set to "constant current mode", the channel behaves like a current generator.
- Common Interlock logic for channels enable/disable and individual input signal for channel Kill function.

Control Software available: GECO2020 with user friendly GUI and CAEN HV Wrapper library for custom SW development. EPICS and LabVIEW also supported



Simply the best Power Supply for your laboratory

Features

- 4 independent HV channels in a fully Desktop form factor
- Channel polarity independently selectable
- SHV coaxial output connectors
- Common floating return
- Very Low Ripple
- Under/overvoltage alert, overcurrent and max. voltage protection
- 2.8" color touch screen display
- Local and Remote control (USB 2.0/Ethernet)
- Interlock logic for unit enable and individual channel kill

In the following tables all the boards belonging to the family are listed together with an overview of the relevant parameters and of all the available Ordering Options.

Model Compare

Model	Max Output V (V)	Max Output I (μ A)	Vset Resolution (mV)	Imon Resolution (nA)	Ripple Typ. (mVpp)	Max Power per Channel (W)	# of channels
DT1419ET	\pm 500	200	10	5 (0.5 with Izoom)	< 3	0.1	4
DT1471ET	\pm 5500	300	10	5 (0.5 with Izoom)	< 5	1.65	4
DT1471HET	\pm 5500	20	100	1 (0.05 with Izoom)	< 5	0.1	4
DT1470ET	\pm 8000	3000	200	50 (5 with Izoom)	< 5 - 15	9 W (<3 kV output) 8 W (>3 kV output)	4

Ordering Options

Code	Description
WDT1419ETXAA	DT1419ET - 4 Channel 500V/200 μ A Desktop HV Power Supply Unit with Ethernet & Touchscreen
WDT1471ETXAA	DT1471ET - 4 Channel 5.5kV/300 μ A Desktop HV Power Supply Unit with Ethernet & Touchscreen
WDT1471HETXA	DT1471HET - 4 Channel 5.5kV/20 μ A Desktop HV Power Supply High Accuracy Unit with Ethernet & Touchscreen
WDT1470ETXAA	DT1470ET - 4 Channel 8kV/3mA (9W max) Desktop HV Power Supply Unit with Ethernet & Touchscreen

up to 5 kV

Free Download
Software

Single Channel USB

**DT547x****NEW**

Desktop High Voltage Power Supplies

CAEN High Voltage power supplies now available in a compact, easy and handy device

Features

- Single Desktop HV channel powered and controlled by USB
- Channel Enable/Disable via front panel switch
- Available with positive or negative polarity
- SHV coaxial output connector
- From 500 V to 5 kV, 1 W maximum power
- Imon Zoom (x10)
- Remote control through USB 2.0
- LabVIEW Instrument Driver
- Dedicated LabVIEW Software

Safety features include:

- Channel can be enabled or disabled through the front panel manual switch or via Interlock logic.
- **Overvoltage and Undervoltage** warning when the output voltage differs from the programmed value.
- **Overcurrent** detection: when the channel attempts to exceed the programmed current limit, it signaled to be in "overcurrent" and enter in a TRIP status. The output voltage is varied to keep the current below the programmed limit for a programmable TRIP time, then the channel is switched off. If TRIP is set to "constant current mode", the channel behaves like a current generator.
- Hardware VMAX: maximum output voltage can be set via front panel potentiometer. VMAX value can be read out via software.

Overview

The DT547x is a new CAEN Power Supply Family providing a Single High Voltage channel in a small size Desktop form factor.

The unit is powered and controlled by any Laptop/PC USB 2.0 port and this make it a really portable and practical solution for testing and educational needs.

A dedicated LabVIEW based Control Software allows for an easy set and monitor of the High Voltage parameters.

The High Voltage output is delivered through SHV connector.

Three versions are available spanning from 500 V to 5 kV and from 200 μ A to 1 mA, meeting the needs of a wide range of applications.

Each unit is provided with Imon Zoom. This feature enhances the Current monitoring, increasing the resolution of a x10 factor according to the specific model.

The HV output Ramp-Up and Ramp-Down rates can be set independently in the range 1 ÷ 500 V/s in 1 V/s steps (1 ÷ 100 V/s for DT5472).

DT547x models features:

- LabVIEW Instrument Driver
- DT547x Control software: LabVIEW Control software with Logging Capability. DT547x Control software allows to set and monitor, through a Graphical User Interface, all the unit's functional parameters. When DT547x Control Software runs, it creates a data-log file that records the changes of the monitoring parameters.



In the following tables all the boards belonging to the family are listed together with an overview of the relevant parameters and of all the available Ordering Options.

Model Compare

Model	Max Output V (V)	Max Output I (mA)	Vset Resolution (V)	Imon Resolution (nA)	Ripple Typ. (mVpp)	Max Power per Ch (W)
DT5470	5000	0.2	1	4 (0.4 with Imon Zoom)	< 10	1
DT5471	3000	0.5	0.5	10 (1 with Imon Zoom)	< 10	1
DT5472	500	1	0.1	20 (2 with Imon Zoom)	< 10	0.5

Ordering Options

Model	Code	Description
DT5470	WDT5470XNAAA	DT5470N - 1 Channel -5 kV/200 μ A USB HV Power Supply Unit
	WDT5470XPAAA	DT5470P - 1 Channel +5 kV/200 μ A USB HV Power Supply Unit
DT5471	WDT5471XNAAA	DT5471N - 1 Channel -3kV/500 μ A (1W max) USB HV Power Supply Unit
	WDT5471XPAAA	DT5471P - 1 Channel +3kV/500 μ A (1W max) USB HV Power Supply Unit
DT5472	WDT5472XNAAA	DT5472N - 1 Channel -500 V/1 mA USB HV Power Supply Unit
	WDT5472XPAAA	DT5472P - 1 Channel +500 V/1 mA USB HV Power Supply Unit



Quad Desktop Linear Power Distributor - DT5423

Desktop Low Voltage Power Supply

Features

- Four DB9 connectors to supply A1422 family and A1424 preamplifiers
- One plug connector to supply DT57xx family desktop digitizers
- Four DB9 connectors with ± 12 V each
- Very Low Noise

Overview

The DT5423 is a desktop linear power supply for A1422 and A1424 preamplifiers and DT57xx Digitizers family. It provides four standard 9-pin "D-type" female connectors to supply up to four A1422 or A1424 preamplifiers. Each output is filtered and fuse protected. The +12 V power supply for the digitizer is provided through a 6 pin Shielded Miniature Circular DIN Connector.

Ordering Option

Code	Description
WDT5423XAAA	DT5423 - Desktop Power Supply for A1422-A1424 Amplifiers & DT57xx Digitizers

up to 8 kV
Reversible Polarity



Free Download
Software



19" Rack-mount with Ethernet & Touchscreen

R14xxET

Rack High Voltage Power Supplies

NEW

CAEN HV Power Supplies now fit your rack in a flexible and reliable unit

Features

- 4 or 8 independent HV channels in a 2U, 19" Rackmount unit
- Channel polarity independently selectable
- SHV coaxial output connectors
- Common floating return
- Very Low Ripple
- Under/overvoltage alert, overcurrent and max. voltage protection
- 2.8" color touch screen display
- Local and Remote control (USB 2.0/Ethernet)
- Interlock logic for unit enable and individual channel kill

Control Software available: GECO2020 with user friendly GUI and CAEN HV Wrapper library for custom SW development. EPICS and LabVIEW also supported



In the following tables all the boards belonging to the family are listed together with an overview of the relevant parameters and of all the available Ordering Options.

Model Compare

Model	Max Output V (V)	Max Output I (µA)	Vset Resolution (mV)	Imon Resolution (nA)	Ripple Typ. (mVpp)	Max Power per Channel (W)	# of channels
R1419ET	±500	200	10	5 (0.5 with lzoom)	< 3	0.1	4
R1419ETD	±500	200	10	5 (0.5 with lzoom)	< 3	0.1	8
R1471ET	±5500	300	100	5 (0.5 with lzoom)	< 5	1.65	4
R1471ETD	±5500	300	100	5 (0.5 with lzoom)	< 5	1.65	8
R1471HET	±5500	20	100	1 (0.05 with lzoom)	< 5	0.1	4
R1471HETD	±5500	20	100	1 (0.05 with lzoom)	< 5	0.1	8
R1470ET	±8000	3000	200	50 (5 with lzoom)	< 5 - 15	9 W (<3 kV) 8 W (>3 kV)	4
R1470ETD	±8000	3000	200	50 (5 with lzoom)	< 5 - 15	9 W (<3 kV) 8 W (>3 kV)	8

Overview

The R14xxET is a new CAEN Power Supply Family providing 4 or 8 independent High Voltage channels in a 2U, 19" Rack-mount unit. Each channel features an independently selectable polarity and common floating return (common return insulated from the chassis ground). High Voltage outputs are delivered through SHV connectors. R14xxET units can be controlled either locally, thanks to a 2.8" touchscreen color LCD display with a complete user interface, or remotely, via USB or Ethernet, taking advantage of the new GECO2020 Control Software. EPICS and LabVIEW are supported.

Different versions are available spanning from 500 V to 8 kV and from 20 µA to 3 mA, meeting the needs of a wide range of applications.

Each unit is provided with Imon Zoom. This feature enhances the current monitoring, increasing the resolution of a x10 or x20 factor according to the specific model.

The HV output Ramp-Up and Ramp-Down rates can be set independently for each channel in the range 1 ÷ 500 V/s in 1 V/s steps (1 ÷ 50 V/s for R1419ET / R1419ETD).

Ordering Options

Model	Code	Description
R1419	WR1419ETXAAA	R1419ET - 4 Channel 500V/200µA 19" HV Power Supply Unit with Ethernet & Touchscreen
	WR1419ETDXAA	R1419ETD - 8 Channel 500V/200µA 19" HV Power Supply Unit with Ethernet & Touchscreen
R1471	WR1471ETXAAA	R1471ET - 4 Channel 5.5kV/300µA 19" HV Power Supply Unit with Ethernet & Touchscreen
	WR1471ETDXAA	R1471ETD - 8 Channel 5.5kV/200µA 19" HV Power Supply Unit with Ethernet & Touchscreen
R1471H	WR1471HETXAA	R1471HET - 4 Channel 5.5kV/20 µA 19" HV Power Supply High Accuracy Unit with Ethernet & Touchscreen
	WR1471HETDXA	R1471HETD - 8 Channel 5.5kV/20 µA 19" HV Power Supply High Accuracy Unit with Ethernet & Touchscreen
R1470	WR1470ETXAAA	R1470ET - 4 Channel 8kV/3mA (9W max) 19" HV Power Supply Unit with Ethernet & Touchscreen
	WR1470ETDXAA	R1470ETD - 8 Channel 8kV/3mA (9W max) 19" HV Power Supply Unit with Ethernet & Touchscreen

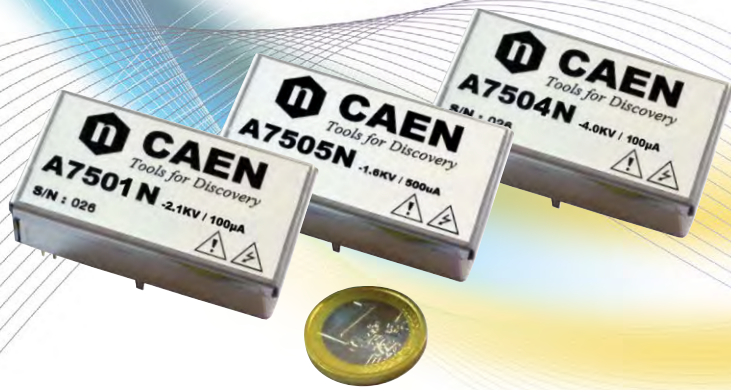
**NEW**

A750x PCB High Voltage Power Supplies

Pin Out

The following diagram describes the Pin assignment:

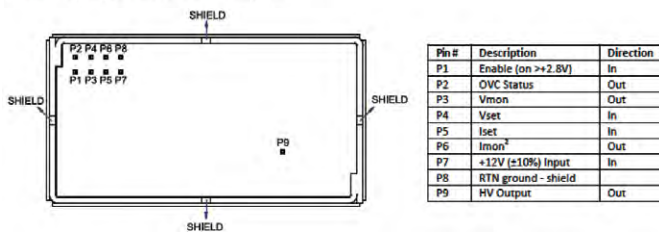

In the following tables all the boards belonging to the family are listed together with an overview of the relevant parameters and of all the available Ordering Options.

Model Compare

Model	Maximum Output V (V)	Maximum Output I (μA)	Ripple Typ. (mVpp)	Vset Input (V)	Imon Output (V)	Vmon Output (V)	Power requirement (mW)
A7501	2100	100	< 5	0 ÷ +2.5	0 ÷ +2.5	0 ÷ +5	< 400
A7504	4000	100	< 10	0 ÷ +2.6	0 ÷ +2.5	0 ÷ +2.5	< 600
A7505	1600	500	< 5	0 ÷ +2.6	0 ÷ +2.5	0 ÷ +2.5	< 1600
A7508	800	50	< 5	0 ÷ +2.5	0 ÷ +2.5	0 ÷ +2.5	< 100

Ordering Options

Model	Code	Description
A7501	WA7501NXAAAA	A7501N -2.1kV 100μA HV Power Supply Module
	WA7501PXAAAA	A7501P +2.1kV 100μA HV Power Supply Module
A7504	WA7504NXAAAA	A7504N -4kV 100μA HV Power Supply Module
	WA7504PXAAAA	A7504P +4kV 100μA HV Power Supply Module
A7505	WA7505NXAAAA	A7505N -1.6kV 500μA HV Power Supply Module
	WA7505PXAAAA	A7505P +1.6kV 500μA HV Power Supply Module
A7508	WA7508NXAAAA	A7508N -800V 50μA HV Power Supply Module
	WA7508PXAAAA	A7508P +800kV 50μA HV Power Supply Module

Safety Features

Overcurrent detection: if the channel attempts to draw a current larger than Iset, the output voltage is varied to keep the current below Iset limit. The channel behaves like a current generator:

- Status Overcurrent Bit: 0÷5 V
- Status On/Off Bit: 0÷5 V
- Protected against short circuits, sparks and humidity

Delivering the excellence of CAEN High Voltage Technology in the palm of your hand!

Features

- Single channel PCB mount High Voltage Power Supply
- High efficiency and low power consumption
- Four models available:
 - A7501 (2100 V / 100 μA)
 - A7504 (4000 V / 100 μA)
 - A7505 (1600 V / 500 μA)
 - A7508 (800 V / 50 μA)
- Positive or negative polarity
- Analog voltage and current Set and Monitor levels
- Very low ripple and noise
- Excellent stability
- Compact package 54x29x17 mm³ (WxLxH)
- High operating temperature range:
 - A7501: -40 °C ÷ +70 °C
 - A7504: -10 °C ÷ +50 °C
 - A7505: -55 °C ÷ +80 °C
 - A7508: -40 °C ÷ +70 °C

Overview

The A750x is a new line of compact, high efficiency, low noise single channel High Voltage DC/DC converters in a PCB mount form factor. Each device can supply a High Voltage output according to an external reference voltage level (Vset) provided by the user.

Maximum current setting (Iset), voltage monitor (Vmon) and current monitor (Imon) are also available. These features make the A750x family suitable for integration in user designed systems or embedded applications.

Four models are currently available, A7501, A7504, A7505, A7508, supplying up to 2100 V/100 μA, 4000 V/100 μA, 1600 V/500 μA and 800 V/50 μA respectively. Each A750x can be provided with either positive or negative polarity. Other models can be designed on request.

Thanks to their excellent stability and special design, A750x Power Supplies are engineered to work in harsh environment and under severe temperature variations.

CAD Altium library components and 3D step models are available on request.

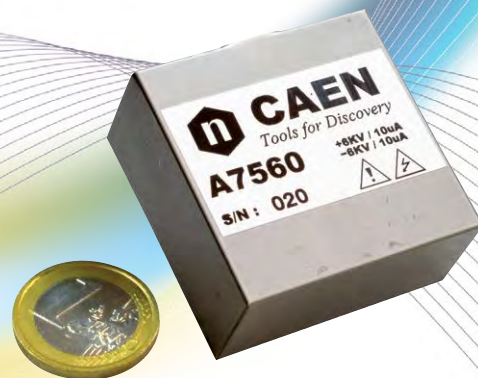
up to ± 6 kV

High Performance with Digital Control

A7560

PCB High Voltage Power Supplies

NEW

The reliability of CAEN digital control technology now available also in a compact HV power supply

Features

- Double channel, opposite polarity PCB mount High Voltage Power Supply
- High efficiency +6 kV/10 μ A, -6 kV/10 μ A output ranges
- Vin: from +5 V - 20% to +12 V + 20%
- General On/Off: 0-5 V
- Power requirement: < 2 W @ full power
- Low ripple and noise
- Setting DAC: 16-bit
- Monitor ADC: 20-bit
- Serial Line: USART (TX, RX)
- Embedded digital control for enhanced performances
- Compact package 49x49x23 mm³ (WxLxH)
- HV out by wire
- Works in magnetic field up to 1 kGauss (optional)
- Available also with analog control:
 - Vset, Iset, Vmon, Imon (0 \div 5 V)
 - Status Overcurrent Bit (0 \div 5 V)
 - Status On/Off Bit (0 \div 5 V)

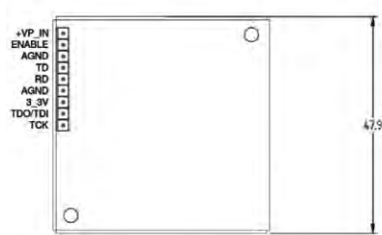

PIN #	Description	Direction
P1	Vin	In
P2	Enable	In
P3	Analog Ground	-
P4	Transmitter Data	Out
P5	Receiver Data	In
P6	Analog Ground	-
P7	Reserved	In/Out
P8	Reserved	In/Out
P9	Reserved	In/Out

Ordering Options

Code	Description
WA7560XAAAAA	A7560 - ± 6 kV 10 μ A High Voltage Power Supply Module with Analog Control
WA7560DXAAAA	A7560D - ± 6 kV 10 μ A High Voltage Power Supply Module with Digital Control
WA7560MXAAAA	A7560M - ± 6 kV 10 μ A High Voltage Power Supply Module with Analog Control working in Magnetic Field
WA7560DMXAAA	A7560DM - ± 6 kV 10 μ A High Voltage Power Supply Module with Digital Control working in Magnetic Field

Overview

The A7560 is a new compact, high efficiency, low noise double channel High Voltage DC/DC converter in a PCB mount form factor.

It can supply a double output High Voltage with opposite polarity according to the user setting.

The module features a digital control managed by an embedded low-power micro-controller. By running a dedicated resident firmware, it can handle calibration, ramp up/down rates, power-on sequence, inner SPI serial bus and self-compensation of nonlinearities for enhanced accuracy.

The unit can be externally controlled and configured by means of an USART serial link. It provides all the relevant information as Voltage and Current monitors, Status and Overcurrent for the safety of detectors as RPCs and others. These features make A7560 suitable for integration in user designed systems or embedded applications.

The A7560 is able to work in magnetic field up to 1 kGauss.

Safety Features

Overcurrent detection: if the channel attempts to draw a current larger than Iset, the output voltage is automatically adjusted to keep the current below Iset limit. Under this condition, the channel behaves as a current generator:

- Status On/Off Bit: 0 \div 5 V (low = OFF)
- Protected against short circuits, sparks and humidity

In the following tables all the boards belonging to the family are listed together with an overview of the relevant parameters and of all the available Ordering Options.

Model Specification

Model	Max Output V (kV)	Max Output I (μ A)	Ripple Typ. (mVpp)	Power requirement (W)
A7560	± 6	10	< 10	< 2

**NEW**

A7501PB

Single Channel High Reliability, High Voltage Power Supply Box

Packaging

A tailored solution for Large Area experiments in harsh environment

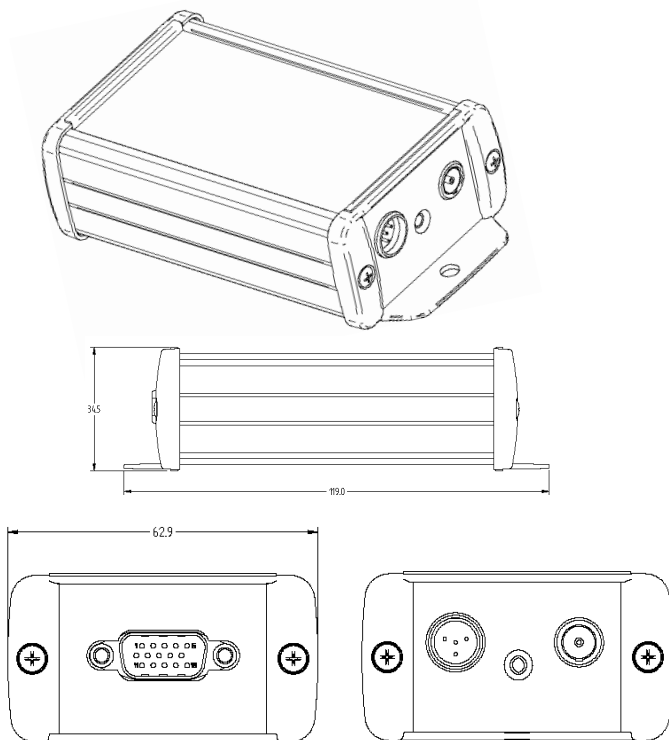

PIN #	Description	Direction
P1	Vmon	Out
P2	Vset	In
P3	Imon	Out
P4	Temp+	Out
P5	+12 V	In
P6	AGND	-
P7	AGND	-
P8	NC	-
P9	Temp-	Out
P10	AGND	-
P11	NC	-
P12	AGND	-
P13	NC	-
P14	AGND	-
P15	AGND	-

PIN #	Description	Direction
P1	AGND	-
P2	Temp-	Out
P3	Imon	Out
P4	Temp+	Out

Features

- Based on A7501 PCB mount HV DC-DC converter
- Temperature working range: $-10^{\circ}\text{C} \div 70^{\circ}\text{C}$
- Designed for long working life in harsh environment
 - Architectural materials chosen to minimize issues due to thermal expansion
 - Layout optimized for the worst foreseen environmental condition
 - Redundancy of internal connections
 - Connection and cabling with stress relief on solder points
 - Stress absorption with silicon resin
 - Several solutions from Aerospace electronics design
- Assembly optimized for easy maintenance operation

Overview

A7501PB is a solution designed for operating in challenging environmental conditions and high thermal excursions.

It relies on the high efficiency PCB High Voltage power supply A7501 embedded in a custom carrier.

In order to assure its functionality for long working periods under severe environmental conditions, several dedicated technical and electrical precautions have been implemented such as stress relief techniques on cabling and soldering points, electrical redundancies, PCB layout design, and use of specific materials to minimize the thermal expansion on PCB and housing mechanics.

These features make A7501PB ideal for Large Area experiments where the possibility of a prompt maintenance intervention is reduced.

Model Specification

Model	Maximum Voltage	Maximum Current	Ripple (Typ.)	Power requirement
A7501	2100 V	100 μA	5 mVpp	< 400 mW

Ordering Option

Code	Description
WA7501PBAAA	A7501PB - High Voltage Power Supply Box for Auger Experiment

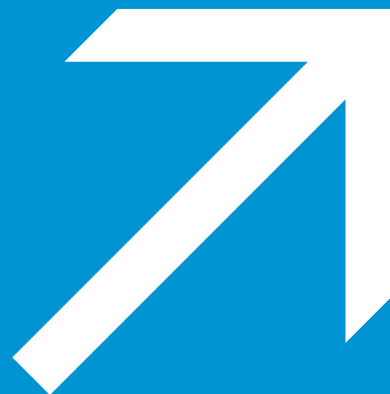

Is your electronics working in
“Hostile” area? Are you in presence
of Magnetic Field or Radiation?

The EASY family is the right
architecture for your installation
where the HV & LV power supplies
are required.

EASY, COTS-based & cost
effective.

Magnetic field: up to 2 kGauss

Radiation:

- up to $1 \cdot 10^{11}$ p/cm² Total Dose
- up to $2 \cdot 10^{12}$ n/cm² Total Dose
- up to 15 kRad Total Integrated Dose

EASY
(Embedded
Assembly
System)



Photo © Michael Hoch - CERN - Switzerland View of the CMS detector electronics housed in two floors of the underground services cavern.

EASY (Embedded Assembly SYstem)

CAEN EASY System: The solution for powering inside the hostile areas

EASY (Embedded Assembly SYstem) is the CAEN high/low voltage power supply solution to be used every time the residual magnetic field and radiation become a problem.

Why EASY?

CAEN has been involved in developing different solutions in order to satisfy the requirements coming from main LHC experiments where the electronic equipment is dealing with high dose of radiation and strong residual magnetic field. In order to provide safe and reliable operations in these “hostile” areas, CAEN developed a solution featuring rad-tolerant and magnetic field resistant components, patenting this technology that is now used in a line of products for “hostile” area. The EASY modules can work in normal conditions with excellent performance as well. Widely used in LHC experiments, producing almost 7,500 electronic units, containing about than 200,000 sub-boards.

System Concept

The EASY power supply is located directly in the hostile area while the control of the system can be done remotely using a Branch Controller (model A1676A) plugged in a SY4527 or SY5527 mainframe located in the control room. Through the mainframe an immediate and “automatic” interfacing with the Detector Control System or the custom control software is achieved using the provided and full reliable OPC server software.

Flexibility and Compatibility

Each branch controller module can handle up to 6 EASY crates. The A1676A is a one unit wide board so each SY4527 power system can house up to 16 branch controller boards, while each SY5527 can house up to 6 branch controller boards, enabling the monitoring up to 96 and 36 EASY systems respectively. The module can work even side by side with standard HV and/or LV boards and the EASY power supplies provide a wide variety of output voltages to satisfy the requirements of most detectors and front end electronics including also POL DC/

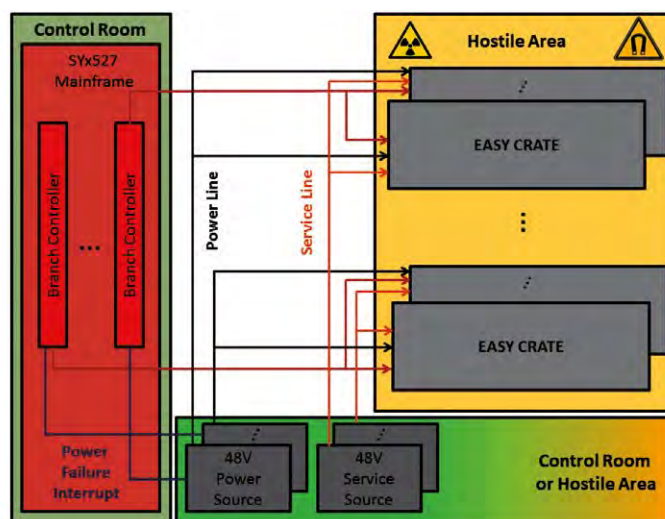
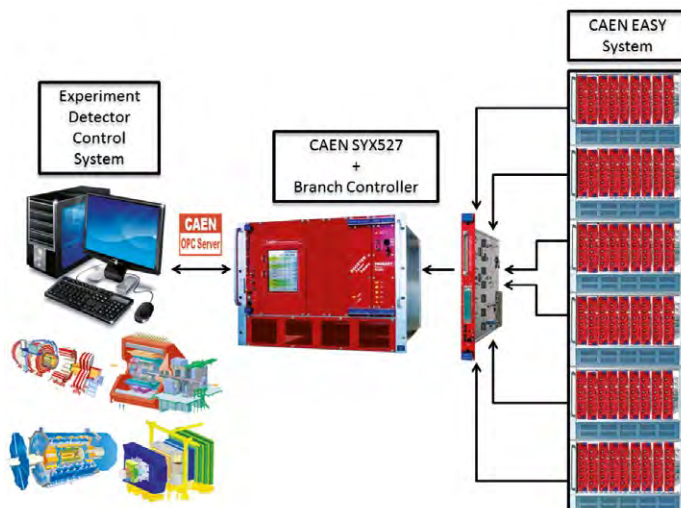

DC converters (Low Voltage up to 100 A and High Voltage up to 12 kV). An unique interface and a cost effective setup for all the experiment's power requirements!

Architecture

The EASY3000 (for boards up to 40 cm long, A3XXX Family) can house up to 10 boards depending on the boards width. As illustrated in the figure, the branch controller is the EASY interface between the mainframe unit (SY4527 or SY5527) and the remote boards in the EASY crate. The branch controller role is to configure the EASY channels as they belong to the supply unit slot in which the branch controller is located. In this way all the channels of the EASY boards, will be considered as channels of the branch control board, increasing hugely the number of channels the system can handle.

Tolerances

- Magnetic field: up to 2 kGauss
- Radiation:
 - up to $1 \cdot 10^{11}$ p/cm² Total Dose
 - up to $2 \cdot 10^{12}$ n/cm² Total Dose
 - up to 15 kRad Total Integrated Dose



Available EASY Board Models

Power Supplies

CFG = Common Floating Ground FF = Full Floating
IF = Individual Floating

Model	# Channels	Voltage Range	Max Output Current per ch.	Max Output Power per ch.	Width (slots)	Max Modules per Crate	Max Channels Per Crate	Working in Hostile Area	Ground
A3006	6 (4 pos. / 2 neg.)	$\pm (4 \div 16)$ V	6 A	90 W	4	5	30	Yes	CFG
A3009	12	$1.5 \div 8$ V	9 A	45 W	4	5	60	Yes	FF
A3009B	12	$2 \div 8$ V	9 A	45 W	4	5	60	Yes	FF
A3009K	12	$0.5 \div 2$ V	9 A	18 W	4	5	60	Yes	FF
A3009HBP	12	$8 \div 14$ V	3 A	42 W	4	5	60	Yes	IF
A3016	6	$2 \div 8$ V	16 A	90 W	4	5	30	Yes	FF
A3016B	6	$2 \div 8$ V	16 A	90 W	4	5	30	Yes	FF
A3016HBP	6	$8 \div 14$ V	6 A	84 W	4	5	30	Yes	IF
A3025	4	$2 \div 8$ V	25 A	150 W	4	5	20	Yes	FF
A3025B	4	$2 \div 8$ V	25 A	150 W	4	5	20	Yes	FF
A3025HBP	4	$8 \div 14$ V	10 A	140 W	4	5	20	Yes	IF
A3050	2	$2 \div 8$ V	50 A	300 W	4	5	10	Yes	FF
A3050B	2	$2 \div 8$ V	50 A	300 W	4	5	10	Yes	FF
A3050HBP	2	$8 \div 14$ V	20 A	280 W	4	5	10	Yes	IF
A3100	1	$2 \div 8$ V	100 A	600 W	4	5	5	Yes	FF
A3100B	1	$2 \div 8$ V	100 A	600 W	4	5	5	Yes	FF
A3100HBP	1	$8 \div 14$ V	40 A	560 W	4	5	5	Yes	IF
A3602	3	$2 \div 7$ V	5 A	35 W	4	10	30	Yes	FF
A3501 p/n	12	$0 \div 100$ V	1 mA	100 mW	2	10	120	Yes	IF
A3512 p/n	6	$0 \div 12$ kV	1 mA	12 W	3	7	42	Yes	IF
A3535 p/n	32	$0 \div 3.2$ kV	0.5 mA	1.75 W	4	5	160	Yes	CFG
A3540 p/n	12	$0 \div 4$ kV	1 mA	4 W	2	10	120	Yes	IF

Front-End Boards

Model	Description	Ch. per Module	Max Output Voltage	Max Output Current	Resolution	Width (slots)	Max Modules per Crate	Working in Hostile Area
A3802	DAC	128	4 V	10 mA	12 bit	1	10	Yes

Front-end Boards - continued

Model	Description	# Channels	Input Range	Resolution	Width (slots)	Max Channels Per Crate	Working in Hostile Area
A3801	ADC	128	0 ÷ 10 V	15-bit	2	10	Yes
A3801A	Temperature Sensor	128	-4 ÷ +125 °C	15-bit	2	10	Yes

Remote Controllers

Model	Description	Output Control Line	Working in Hostile Area
A1676A	Branch Controller	6	Yes

EASY Crates

Model	Description	Max Modules per Crate	Depth	Height	Width	Width T.E.	Working in Hostile Area
EASY3000	Crate	10	65 cm	6 U	19"	84	Yes
EASY3000B	Crate with Bolt Conn.	10	65 cm	6 U	19"	84	Yes
EASY3000S	Front Access Crate	10	65 cm	6 U	19"	84	Yes
EASY3000M	Mini Crate	4	50 cm	6 U	7.2"	36	Yes

Fan Units

Model	Description	Depth	Height	Width	Width T.E.	Working in Hostile Area
A3000FB	Fan Unit for EASY3000	65 cm	2 U	19"	84	No
A3000F	Fan Unit for EASY3000	65 cm	2 U	19"	84	No

Bulk Power Supplies

Model	Description	AC Input	DC Input	Max Output Power	Working in Hostile Area
A3484	AC/DC Converter for EASY3000	400V 3-phase	48 V	2500 W	No
A3485	AC/DC Converter for EASY3000	400V 3-phase	48 V	5000 W	No
A3486	AC/DC Converter for EASY3000	220/400V 3-phase	48 V	2x2000 W or 1x4000 W	Yes

For more information, please visit our web site:

www.caen.it/easy

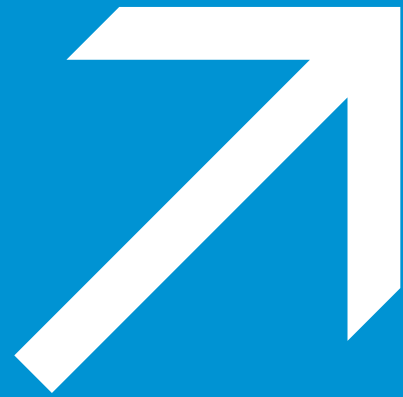

A typical requirement which is often underestimated is the need of High Power, Low Voltage channels. This may be needed for special front end electronics, often placed in the detector cavern, which need to be supplied by an external powerful source, with high reliability and remote wire sensing, to reach the exact low voltage supply even with tens of metres of cables. All the above can be fulfilled by the SY8800 Universal Multichannel Low Voltage Power Supply System, which provides the usual flexibility of its modular design with the highest standards of CAEN quality.

**High Power
Low Voltage
System**



SY8800 (1250 W US - 2500 W EU)

Universal Multichannel Low Voltage Power Supply System

High Density and High Power for your low voltage applications

Features

- 3U x 19" x 35 cm crate size
- Floating channels
- Local and Remote Control
- Remote control via Ethernet, USB, CANBUS and RS232
- Max output power: 2.5 kW @ 220 Vac, 1.5k W @ 115 Vac
- Up to 8 independent channels
- Low noise
- 6 Power Modules available:
 - 2 ÷ 7 V 550/1100 W
 - ±7 ÷ 16 V 550/1100 W
 - ±20 ÷ 28 V 550/1100 W
- 10 mV Voltage Set/Monitor resolution
- 100/200 mA Current Set/Monitor resolution (2 ÷ 7 V)
- 20/40 mA Current Set/Monitor resolution (±7 ÷ 16 V/±20 ÷ 28 V)
- Individual channel ON/OFF
- Sense wires for the voltage drop recovery
- 4 Analog Input, 4 Digital Input, 4 Digital Output
- Fans embedded for vertical cooling

In the following tables all the boards belonging to the family are listed together with an overview of the relevant parameters and of all the available Ordering Options.

Module Compare

Module	Voltage Range	Channels per module	Max Current	Max Power	Module width	Vset/Vmon res.	Iset/Imon res.
M01	2 V÷7 V	1	110 A	550 W	1	10 mV	100 mA
M21	2 V÷7 V	1	220 A	1100 W	2	10 mV	200 mA
B01	± 7 V÷16 V	2	23 A	550 W	1	10 mV	20 mA
B21	± 7 V÷16 V	2	46 A	1100 W	2	10 mV	40 mA
B02	± 20 V÷28 V	2	11 A	550 W	1	10 mV	20 mA
B22	± 20 V÷28 V	2	22 A	1100 W	2	10 mV	40 mA

Overview

The SY8800 is a high density floating low voltage power supply system, designed to power low noise electronics with medium and high currents.

Six Power modules have been developed so far:

- 2 ÷ 7 V 550/1100 W (typ. 110/220 A @5 V)
- ±7 ÷ 16 V 550/1100 W (typ. 23/46 A @±12 V)
- ±20 ÷ 28 V 550/1100 W (typ. 11/22 A @± 24 V)

The system is provided with Remote Sensing Lines to compensate for the voltage drop over the connection cables. Safety features include:

- Over / under voltage protection when the output voltage differs from the programmed value
- Programmable maximum channel output voltage limit (VOVP): the channel is tripped off when its output voltage exceeds VOVP.
- Overcurrent detection: if a channel tries to draw a current larger than its programmed limit, it is switched off.
- Channels can be enabled or disabled through the Interlock logic.

The voltage output Ramp Up/Down time may be selected independently for each channel in 5 ms steps. Module control can take place either locally, assisted by a Graphic OLED display or remotely, via Ethernet, USB, CANBUS and RS232.

Control Software available: CAEN HV Wrapper library for custom SW development.



Ordering Options

Code	Description
WSY8800XXXXX	SY8800 - Universal Multichannel Low Voltage Power Supply System (1250W US - 2500W EU)
WPERS8800M01	M01 - 1 Ch. LV Floating Power Module 2V÷7V / 110A (550W)
WPERS8800M21	M21 - 1 Ch. LV Floating Power Module 2V÷7V / 220A (1100W)
WPERS8800B01	B01 - 2 Ch. LV Floating Power Module ± 7V÷16V / 23A (550W)
WPERS8800B21	B21 - 2 Ch. LV Floating Power Module ± 7V÷16V / 46A (1100W)
WPERS8800B02	B02 - 2 Ch. LV Floating Power Module ± 20V÷28V / 11A (550W)
WPERS8800B22	B22 - 2 Ch. LV Floating Power Module ± 20V÷28V / 22A (1100W)



CAEN provides a complete software range to control, monitor and configure its Power Supply products.

These tools, which support the most used operating systems, spread from low level libraries, to be used as a source for customer designed software, to all-inclusive Control Software with user friendly graphical interfaces, to meet any application need.

Advanced control via OPC Server, SNMP and EPICS is supported, in order to easily include CAEN power supplies within existing setups featuring such standards.

Thanks to this effort, it is now easier to take advantage of the CAEN power supply experience.

All CAEN Control Software are available for free download on the www.caen.it web site, as well as User's guides that allow to better understand all the tools' capabilities.



**Power Supply
Control
Software**

FREE
DOWNLOAD

GECO2020

GEneral COntrol Software for CAEN HV Power Supplies



Simply your Plug & Play control software for all CAEN power supplies

Overview

GECO2020 is a graphical application that allows to manage all the CAEN Power Supplies whatever their form factor (Multichannel Power Supply System, VME, NIM, Rack or Desktop).

Operation with V65xx VME Power Supplies requires the use of CAEN VME Bridges; NDT-DT-R14xxET NIM, Desktop, Rack Modules can be controlled via USB and Ethernet; N14xx NIM modules can be controlled via USB and Ethernet, if CAEN NIM8301/8304 Crates are used.

The Multichannel Power Supply Systems can be controlled via Ethernet or Wi-Fi.

All Mainframe, Board and Channel and parameters related to the SY4527 and SY5527 Power Supply Systems, and to the VME, NIM, Rack and Desktop Programmable HV Power Supplies can be easily monitored and programmed: from the speed of the rack cooling fans to the channel HV ramp rates.

Additional features include channel groups management, custom channel configuration.

Features

- CAEN General Control SW for High Voltage Modules and Systems: SYx527, N14xx, N14xxET, NDT14xx, DT14xxET, R14xxET, V65xx, DT55xxE power supplies are managed by the host PC running the CAEN GECO2020
- Dashboard capability: easy multi-system control, also with set ups mixing various power supply types (SYx527, NIM, VME, DT etc.).
- Optional advanced Scripting and Logging capabilities for SYx527 systems: you can create your system configuration files that can be recalled at any time and log files recording any functional parameter change.
- Logging capability for NIM, VME and Desktop power supplies: keep trace of any functional parameter change.
- Improved Graphical User Interface friendliness
- Management via external Host PC running Windows (32-64 bit) or Linux (32-64 bit)
- Power Supply control via Ethernet, USB, Optical Link communication paths (depending on power supply unit availability)



Many systems, one software interface: full parallel control with GECO2020

FREE DOWNLOAD 

CAEN HV Wrapper

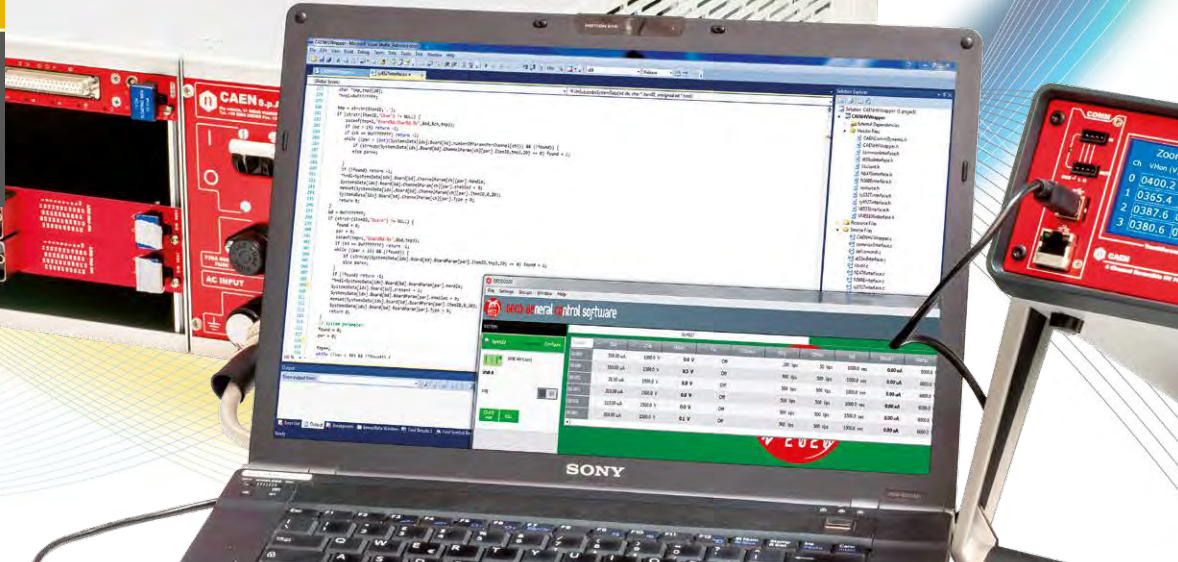

CAEN HV Wrapper

Library for CAEN Power Supply Control



Do you need to integrate CAEN Power Supplies in your control software? Here you have all you need

Overview

CAEN HV Wrapper is a set of ANSI C functions which allows to control CAEN devices. It contains a generic software interface independent by the Power Supply models and by the communication path used to exchange data with them.

CAEN HV Wrapper is logically located between a higher level application and the device to be accessed.

Features

- Function Library for full control of all the CAEN Power Supply products, through the development of higher level applications, such as the CAEN GE2020
- Available for Windows (C, LabVIEW) and Linux (C) operating systems
- Unit control via Ethernet, USB, Optical Link communication paths (depending on device availability)
- Supports SYx527 systems, NIM/VME/Desktop/Rack power supplies, NIM/VME crates, N568E spectroscopy amplifier
- Available both as ANSI C function set and LabVIEW VI's suite

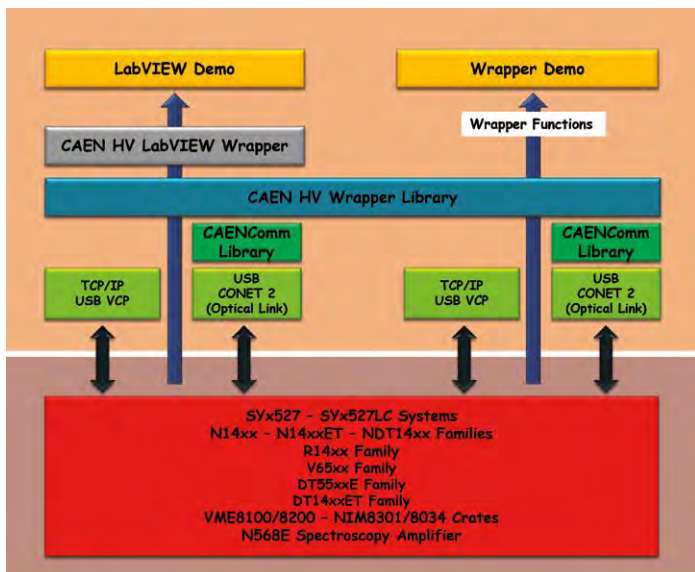

The HV Wrapper Library in the CAEN software and libraries conceptual scheme

FREE
DOWNLOADCAEN
HiVoCS

HiVoCS

Web based Control Software for SY4527 and SY5527 Systems



The web interface to control our instruments from any computer. No software required!!! Simply open your browser

Overview

The HiVoCS is the web tool that allows to manage the SY4527/SY5527 Connection status and system/board upgrade; the featured channel controller allows to handle all the functional parameters of the HV boards. Moreover the tool implements also the EPICS (Experimental Physics and Industrial Control System) service support.

Features

- Web based tool: open your browser, type the SYx527 IP address, log-in and manage the system!
- Includes CAEN HVPSS Channels Controller to manage HV channels parameters (requires Java Runtime Engine pre-installed)
- Allows to manage all power supplies and to install firmware upgrades
- Management via external Host PC running Windows or Linux
- Allows to access SYx527 systems via Ethernet
- Includes EPICS service support

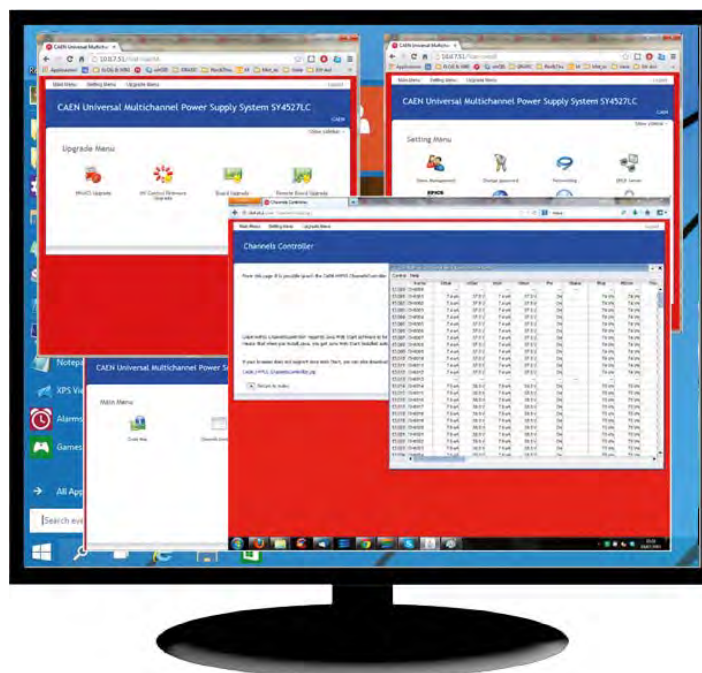

View of the HiVoCS monitor and control windows

FREE
DOWNLOAD

CAEN



CAEN SY Smart Touch for SY4527 and SY5527 Systems

ANDROID APP ON
Google Play

Power Supplies Control & Monitor at your finger tips!

Overview

The CAEN SY Smart Touch control software is the tool that allows to manage the SYx527 Multichannel Power Supply Systems through the CAEN 10.4" and 5.7" LCD Color Touchscreens (optional items for the SYx527 systems); all the system parameters and controls are available at your finger tip!

If your SYx527 is connected to the network, the CAEN SY Smart Touch App for Android™ devices provides also a remote system full control from your smartphone or tablet (coming soon).

Features

- Allows standalone control for SY4527 and SY5527 systems
- All system parameters available at your finger tip
- Dedicated Android application for SY4527/SY5527 system control via Smartphone or Tablet. Available for free download from App Store (coming soon)

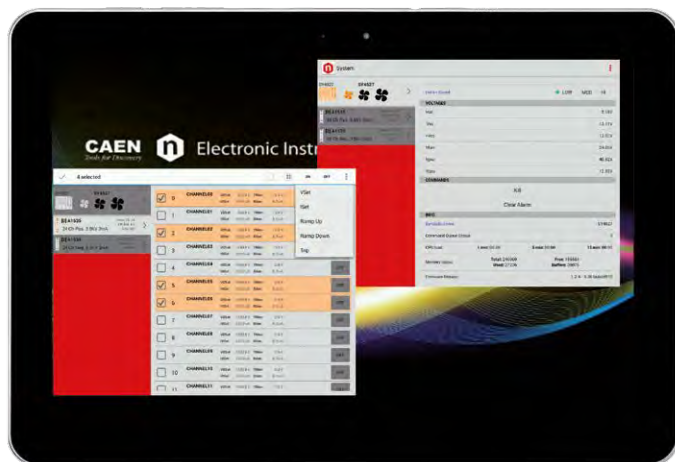

View of the Smart Touch monitor and control windows on your tablet

FREE
DOWNLOADCAEN
LabVIEW

LabVIEW Instrument Driver for Power Supply Modules



Increased LabVIEW support. Free VI download from CAEN website

Overview

Power Supply Modules LabVIEW Instrument Driver is a set of VI's, developed for LabVIEW 2009 and later releases (LabVIEW™ is a Trademark of National Instruments Corp.), that allow to configure and monitor all parameters of remotely controlled CAEN Programmable HV Power Supply modules. The supported power supplies are: N14xx, N14xxET, NDT14xx, R14xxET, DT14xxET, DT55xxE and DT547x families. LabView Demo Control applications are also provided.

Features

- LabVIEW Instrument Driver for N14xx, N1exxET, NDT14xx, R14xxET, DT14xxET, DT55xxE and DT547x Power Supplies
- Ethernet and USB communication paths supported (depending on module)
- Demo control SW included (executable and source code)
- VI's organized in groups, for developer's friendliness
- Also available in the download area of the National Instruments website



A user friendly LabVIEW interface for controlling your setup

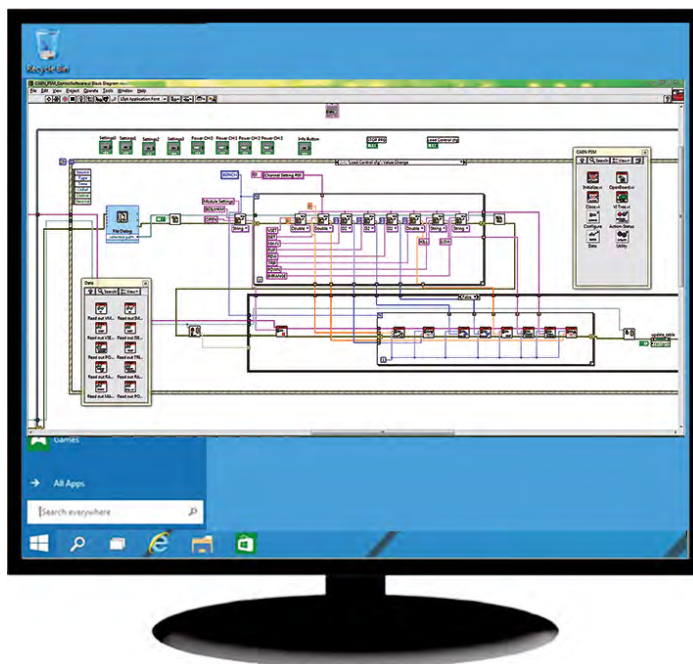

Block diagram and G code view

FREE DOWNLOAD 

CAEN
OPC Server

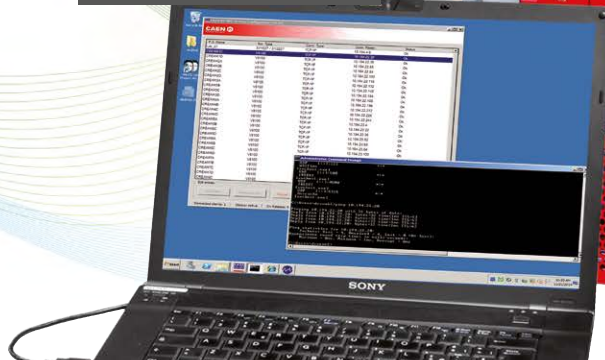

OPC Server for CAEN Power Supplies



Your OPEN interface for Plug & Play connectivity

Overview

CAEN, in close collaboration with CERN, has developed an OPC server which allows powerful, flexible and yet simple control of its power supply systems by any OPC compliant client application. OPC (OLE for Process Control) is an open interface based on the OLE/COM and DCOM technology; OPC offers "Plug & Play" connectivity between disparate hardware devices. The introduction of the OPC interface has caused the number of driver developments, which manufacturers implement for their hardware products, to be reduced to only one: the OPC server. On the other hand, OPC client applications, from any vendor, can communicate with the OPC server to exchange data in a standard way. Each device property is accessed via an OPC item.

Features

- OPC (OLE for Process Control) Server: open interface based on OLE/COM and DCOM technology
- Windows (32-64 bit) Operating System supported
- Ideal for heterogeneous set ups: each device parameter is accessed via an OPC item
- Ethernet, USB, Optical Link communication paths (depending on used device)
- Supports SYx527(LC), V65xx, VME8x00, NIM8301/8304
- Allows powerful, flexible and easy control of CAEN power supplies via OPC client application
- Developed in close collaboration with CERN

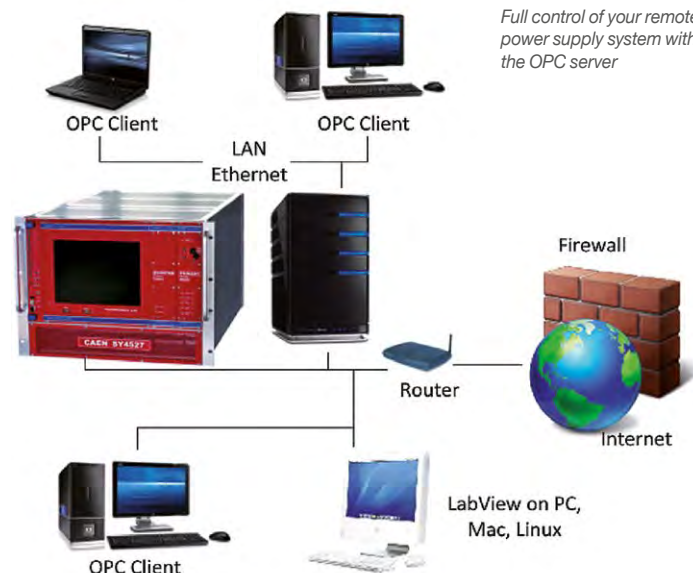

Full control of your remote power supply system with the OPC server

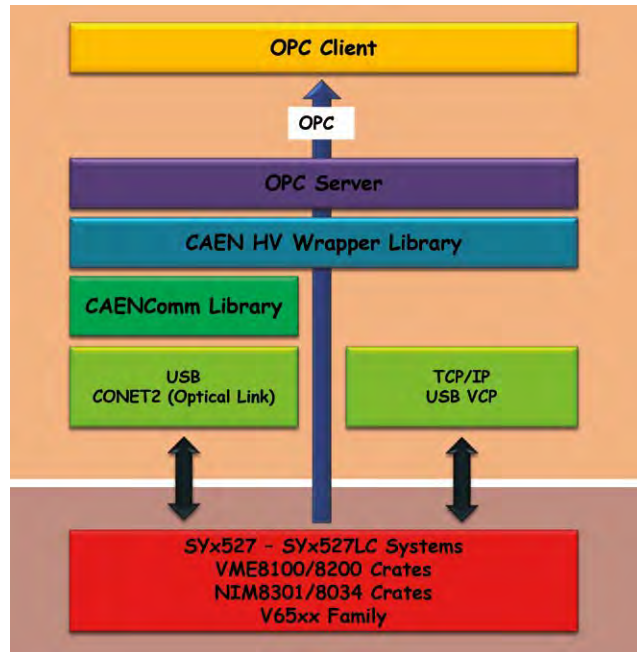

The OPC Server in the CAEN software and libraries conceptual scheme



FREE
DOWNLOAD



EPICS



EPICS Input/Output Controller for SY527 Systems and Power Supply Modules

The EPICS drivers are here. Download it for free for easy integration and control

Overview

EPICS (Experimental Physics and Industrial Control System) is a set of software tools and applications which provide a software infrastructure for use in building distributed control systems, widely used to control experimental physics and industrial electronics.

The most recent CAEN Power Supplies integrates an EPICS Service that provides access to a Process Variable using the Channel Access Protocol. Process Variable is a named piece of data associated with the system, such as status, readback, setpoint, parameter.

Features

- EPICS Input/Output Controller (IOC) providing functional Process Variables (PVs)
- Two versions available:
 - EPICS IOC (PSM): for NDT14xx, R14xxET, DT14xxET, N14xxET, N14xx and DT55xxE Power Supply Families
 - EPICS IOC (SY4527/SY5527): for SY4527 and SY5527 Systems (embedded by HiVoCS)
- Ethernet and USB communication paths supported (depending on system)
- Requires an EPICS client software run by Host PC, to manage all HV system parameters
- For more information about EPICS visit Argonne National Laboratory EPICS site: <http://www.aps.anl.gov/epics/>

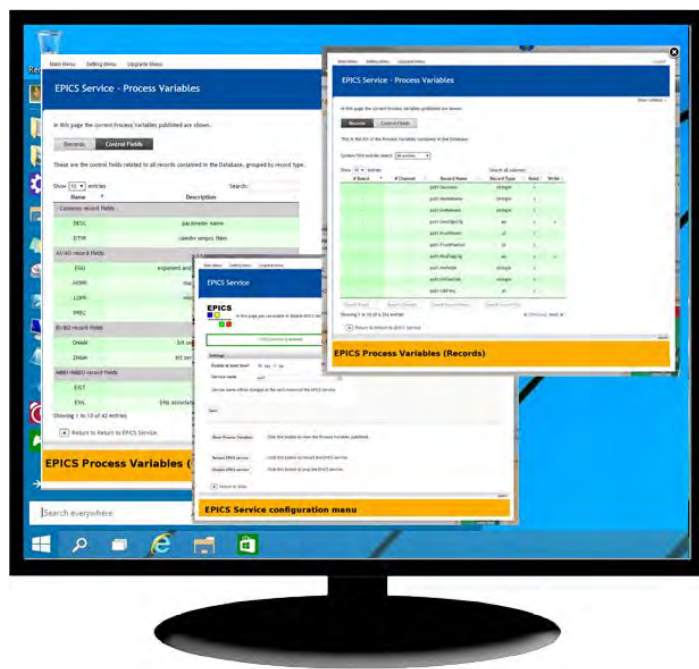

View of the EPICS development environment windows

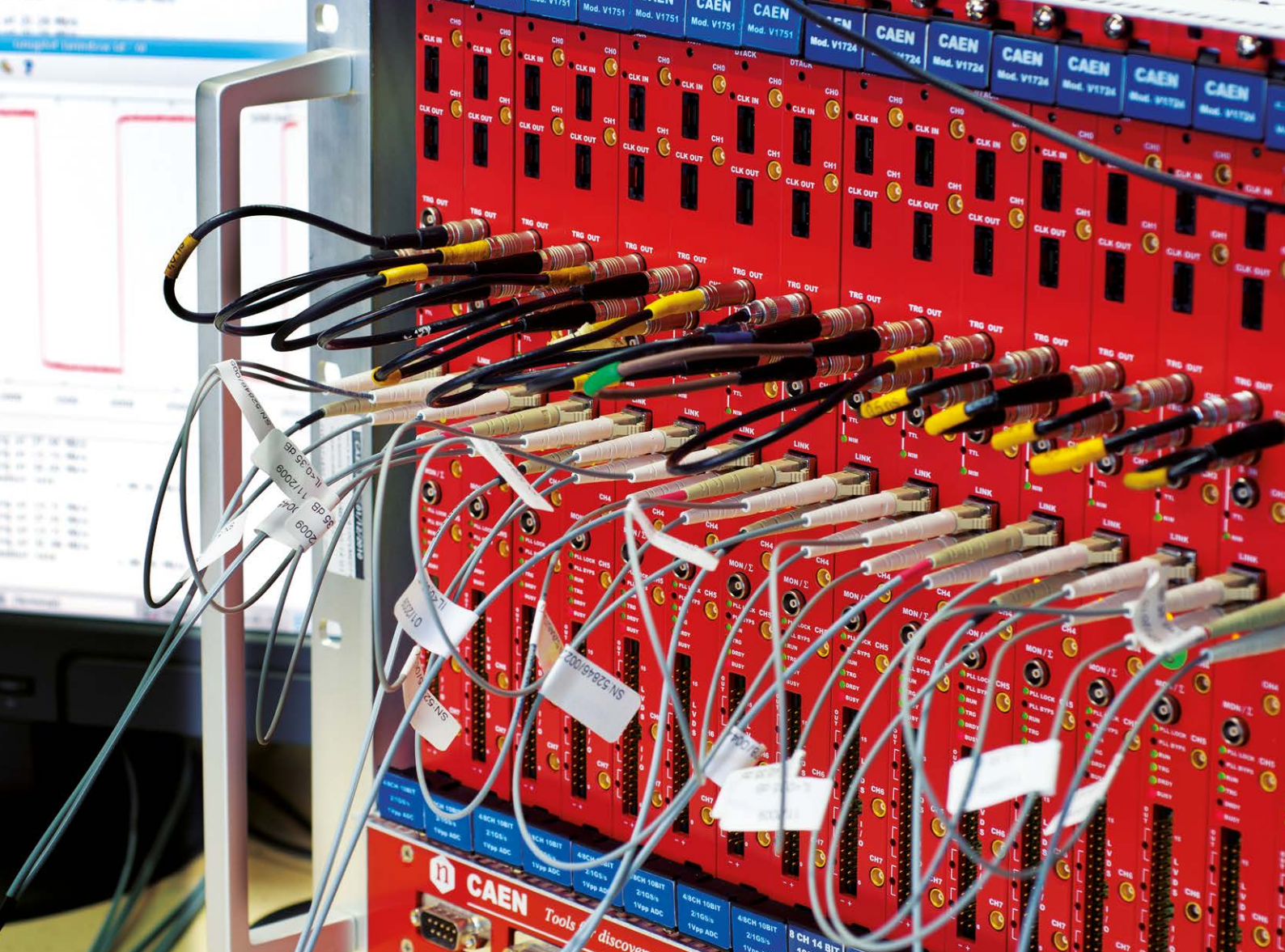

MODULAR PULSE PROCESSING ELECTRONICS

CAEN Modular Pulse Processing Instrumentation: from traditional chains to digitization

The Modular Pulse Processing Instrumentation is the interface between the experiment and the scientist. It extracts information from the detectors, allowing all data to be acquired and analyzed.

- **Waveform Digitizers**
- **VME Electronics**
- **NIM Electronics**
- **Preamplifiers**
- **Powered Crates**



Introduction to Modular Pulse Processing Electronics

Since the early years of its life, CAEN has provided modular electronics to laboratories and experiments of different size and in many different fields of Physics research.

The main distinctive feature of CAEN products is the ability to handle the multiplicity of signal channels provided by the detectors at the most challenging output rates.

CAEN provides a complete and ever increasing set of instrumentation, from Preamplifiers to Data Acquisition to Triggering Electronics and Logic Functions. Most of the instrumentation is available in the most popular standard form factors and bus protocols, such as VME, NIM, and PCI/e.

CAEN production includes also the Powered Crates in the above mentioned standards, as most of the equipment, exception made for the Desktop units, needs to be housed in Crates for their operation. Crate controllers for VME complete our offering and allow control and data acquisition from the relevant boards.

To overcome the limits of traditional analog acquisition chains, CAEN has recently extended its products range with the introduction of a complete family of Digitizers. It consists of several models differing in sampling frequency, resolution, number of channels, form factor, memory size and other parameters.

In parallel with the hardware development, CAEN has put a great effort in developing algorithms for the Digital Pulse Processing (DPP). A DPP algorithm can be installed on the FPGA of the digitizer allowing on-line analysis and implementing new acquisition methods that go beyond the simple waveform recording.

From traditional chains to digitizers, CAEN can provide the best Modular Pulse Processing Instrumentation for your applications.

Waveform Digitizers

The basic principle is to acquire the complete signal from an input channel, convert it to digital by using a fast ADC, then perform calculations on the digital data directly on an FPGA available on board.

A digitizer with DPP becomes thus a new instrument that represents a fully digital replacement of most traditional modules such as Multi and Single Channel Analyzers, QDCs, TDCs, Discriminators and many others.

Available in different form factors, VME, NIM and Desktop, they are the result of all the experiences collected by CAEN in signal processing and data acquisition systems and have been designed driven by the application context, such as Medical Imaging, Homeland Security and Environmental Monitoring.



VME Electronics

The VERSAmodule Eurocard bus is one of the trademarks of CAEN instrumentation catalog. Widely used both in the industry and in the research communities it combines reliability, robustness and flexibility.

CAEN VME products represent a benchmark both in test and measurements and in small and large data acquisition installations.

CAEN is proud of offering the largest selection of VME boards for the research community.

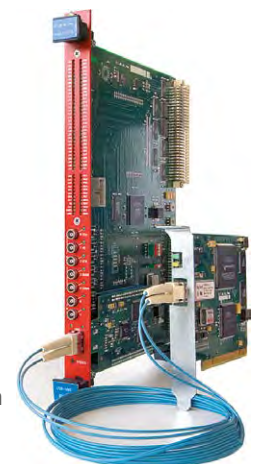

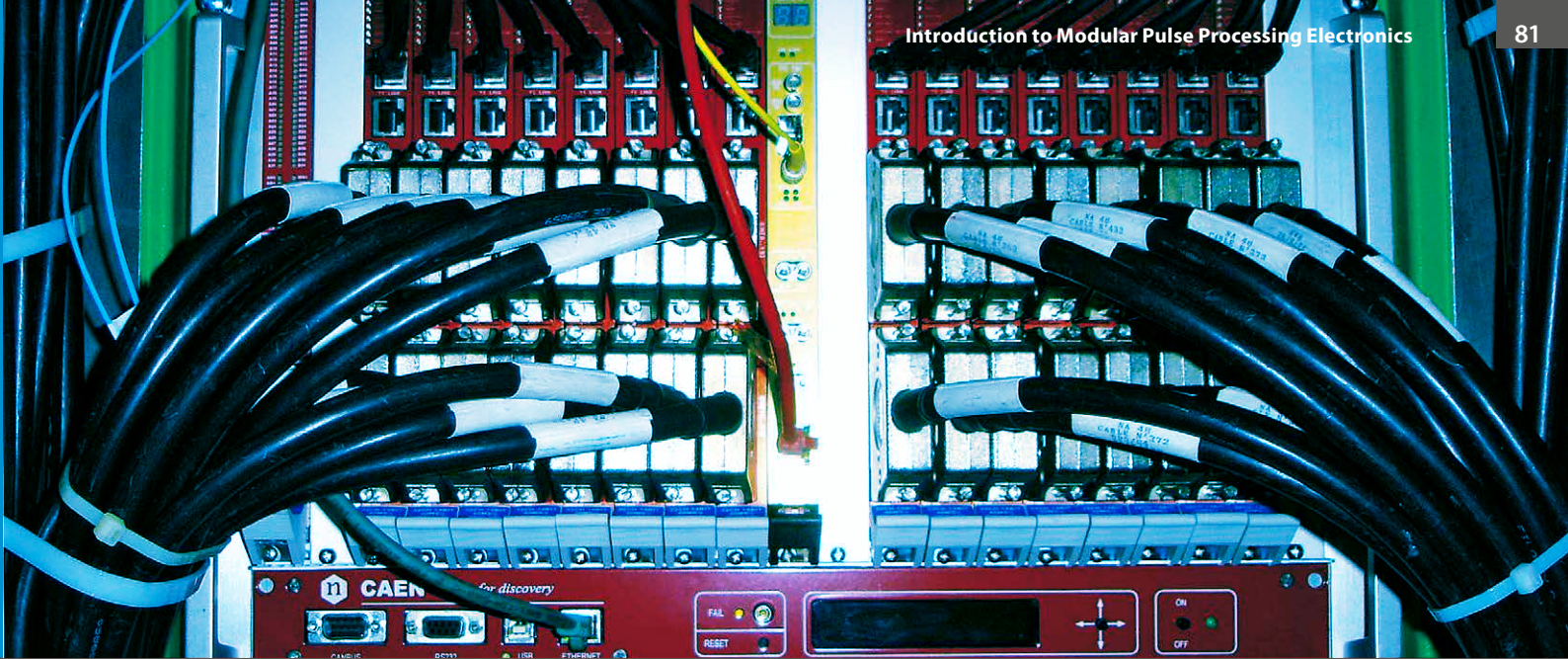

Introduction to Modular Pulse Processing Electronics

NIM Electronics

The NIM-Nuclear Instrumentation Module standard is a very popular form factor widely used in experimental particle and nuclear physics setups.

Defined the first time by the U.S. Atomic Energy Commission's report TID-20893 in 1968-1969 is still nowadays widely used in universities and research centers around the world mainly because of its simplicity.

CAEN offers a wide selection of NIM instrumentation for test setups and data acquisition.



Preamplifiers

The preamplifier is usually the first stage in the electronic chain and its role is to amplify the detector signal to a level suitable for further electronics modules.

According to the timing and amplitude specifications of the input signal, CAEN offers a selection of preamplifiers suitable for both small applications and large Nuclear/Subnuclear Physics experiments, providing the right choice for a good data acquisition chain.



Powered Crates Electronics

A powered crate is mandatory to make a VME or NIM board work, providing it the necessary power supply, allowing the communication between the user and the board itself and cooling it down by means of fan units.

CAEN can offer a selection of NIM, VME and Hybrid Powered Crates with different configuration of power-supplies and back-planes.



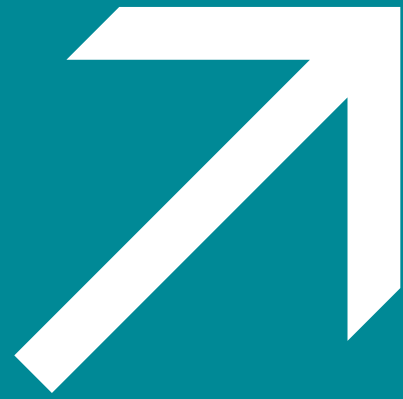

Digital based DAQ are now a well established technique for the readout of both simple and complex experiments. The flexibility and multipurpose capability offered by this approach make it an ideal solution for the researchers needs. CAEN followed this digital revolution since the beginning and can now offer a wide selection of digitizers that can be used with a variety of detectors in different applications.



Digitizer Families
Waveform Recording
Digital Pulse Processing (DPP)
Tools



Introduction to Waveform Digitizers

CAEN has developed a complete family of digitizers that consists of several models differing in sampling frequency, resolution, number of channels, form factor, memory size and other parameters.

The following table lists all models currently available. In parallel with the hardware development, CAEN has made a big effort in developing algorithms for the Digital Pulse Processing (DPP); the user can install a DPP algorithm on the FPGA of the digitizer (firmware upgrade), run

it on-line and implement new acquisition methods that go beyond the simple waveform recording. A digitizer with DPP becomes a new instrument that represents a fully digital replacement of most traditional modules such as Multi and Single-Channel Analyzers, QDCs, TDCs, Discriminators and many others.

Model ⁽¹⁾	Form Factor	N. of ch. ⁽²⁾ Single-Ended	Max. Sampling Frequency (MS/s) ⁽²⁾	Resolution (bit)	Input Dynamic Range (Vpp) ⁽²⁾	Bandwidth (MHz) ⁽²⁾	Memory (MS/ch) ⁽²⁾	DPP firmware ⁽³⁾
x720	VME	8	250	12	2	125	1.25 / 10	PSD
	Desktop/NIM	4 / 2						
x724	VME	8	100	14	0.5 / 2.25 / 10	40	0.5 / 4	PHA, DAW
	Desktop/NIM	4 / 2						
x725	VME	16 / 8	250	14	0.5 - 2	125	0.64 / 5.12	PHA, PSD, ZLEplus COMING SOON
	Desktop/NIM	8						
NEW	VME	16 / 8	500	14	0.5 - 2	250	0.64 / 5.12	PHA, PSD, ZLEplus COMING SOON
	Desktop/NIM	8						
x730	VME	16 / 8	500	14	0.5 - 2	250	0.64 / 5.12	PHA, PSD, ZLEplus COMING SOON
	Desktop/NIM	8						
x740	VME	64	62.5	12	2 / 10	30	0.19 / 1.5	QDC
	Desktop/NIM	32						
x751	VME	8 - 4	1000 - 2000	10	1	500	1.8 - 3.6 / 14.4 - 28.8	PSD, ZLEplus
	Desktop/NIM	4 - 2						
x761	VME	2	4000	10	1	1000	7.2 / 57.6	n.a.
	Desktop/NIM	1						
SWITCHED CAPACITOR	x742	VME	5000 ⁽⁴⁾	12	1	500	0.128 / 1	n.a.
		Desktop/NIM						
SWITCHED CAPACITOR	x743	VME	3200 ⁽⁴⁾	12	2.5	500	0.007	n.a.
		Desktop/NIM						

(1) The x in the model name is V1 for VME, VX1 for VME64X, DT5 for Desktop and N6 for NIM

(2) The indication "size 1/ size 2" denotes different model versions while "size 1 - size 2" denotes different model operating modes

(3) Digital Pulse Processing (DPP) firmware:

- DPP-PHA: Pulse Height analysis (Trapezoidal Filter);
- DPP-PSD: Pulse Shape Discrimination;
- DPP-ZLEplus: Digital Pulse Processing for the Zero Length Encoding (enhanced Zero Suppression algorithm);
- DPP-DAW: Digital Pulse Processing for Dynamic Acquisition Window
- DPP-QDC: Digital Pulse Processing for Charge to Digital Converter

Note: DPP-CI is no longer supported. To perform Charge Integration, please refer to the DPP-PSD.

(4) Sampling frequency of the analog memory (switched capacitor array); A/D conversion takes place at lower speed (thus generating a Dead Time).



Introduction to Waveform Digitizers

Principle of Operation

CAEN Digitizer shares with a digital oscilloscope essentially the basic operating, where the analogue signal is sampled by a flash ADC, whose output, i.e. the stream of digital samples, is continuously read by an FPGA and stored in a circular memory buffer of a programmable size. At the arrival of the trigger, the buffer is frozen and made available for the readout, while the acquisition can continue in a new buffer.

However, there are few important differences between a digitizer and a commercial digital oscilloscope:

- On-line digital pulse processing (DPP) and data reduction
- Dead-timeless waveform recording
- Independent channel self-triggering and event acquisition
- Multi-board synchronization for system scalability
- High bandwidth data readout links

The benefits of the digital approach are great stability and reproducibility, ability to reprogram and tailor the algorithms to the application, ability to preserve the information of the signal along the entire acquisition chain, flexibility, better correction of baseline fluctuation, pile-up, ballistic deficit, etc.. All in one board.

CAEN Digitizer block diagram:

- The motherboard defines the form-factor; it contains one FPGA for the readout interfaces and the services
- The daughterboard defines the type of digitizer; it contains the signal conditioning input stage, the ADCs, the FPGA for the data processing and the memories

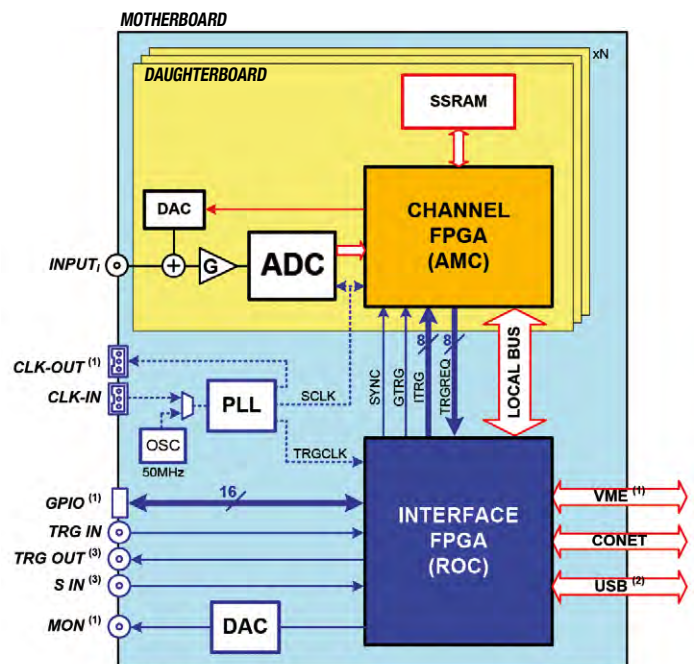
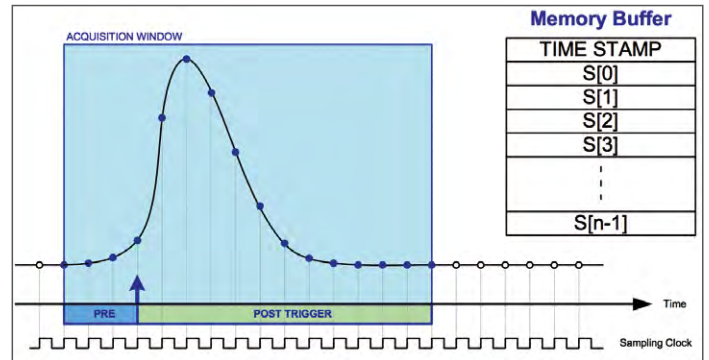

(1) VME boards only
 (2) Desktop/NIM boards only
 (3) for Desktop/NIM boards, TRG-OUT = GPO, S-IN = GPI

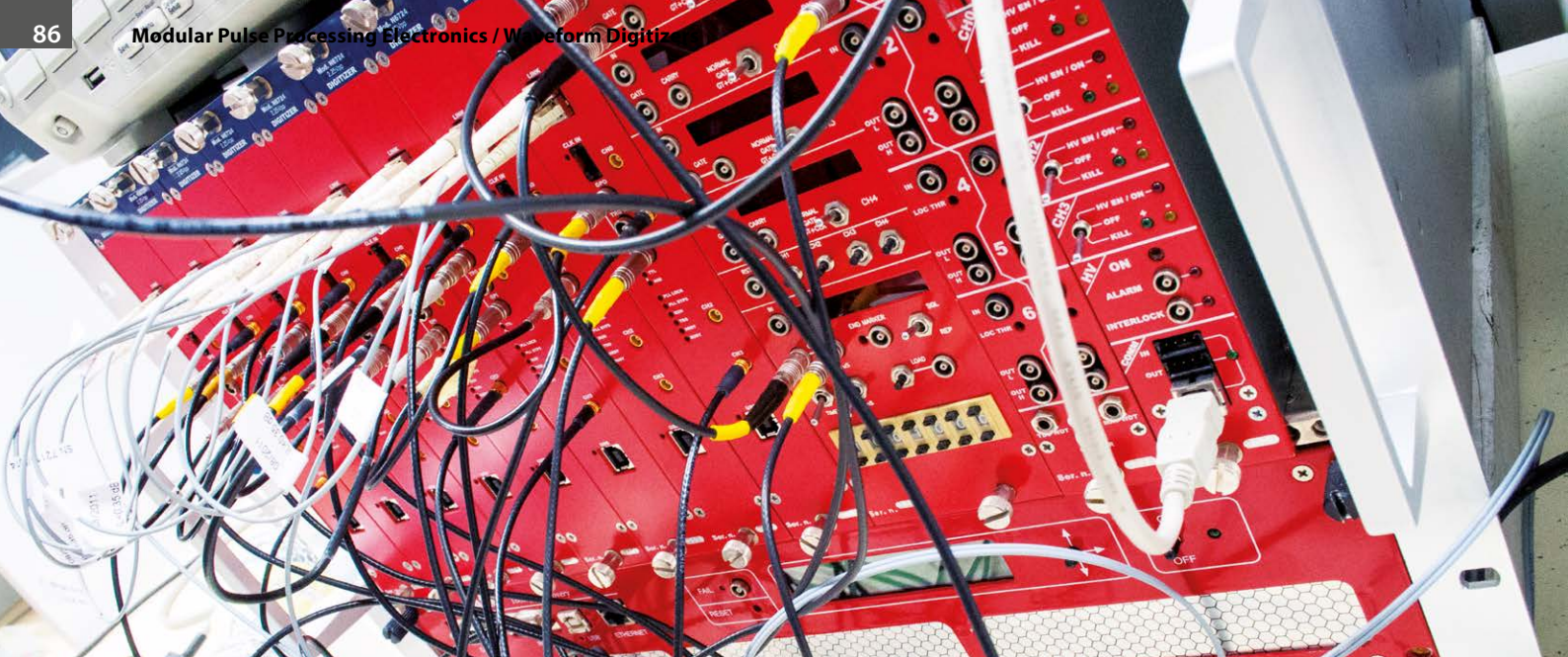

Introduction to Waveform Digitizers

1. Digitizers allow for dead-timeless acquisition.

The digitizers have the ability to accept two consecutive triggers very close to each other thanks to the multi-buffer memory management: there is no dead time between an acquisition window and the next one. It is even possible to accept two triggers for which the acquisition windows overlap.

Dead-timeless feature is not supported by all digitizer models and all the firmware.

2. High flexibility of trigger configuration

Each channel of the digitizer is able to implement a digital discriminator that generates a trigger when a certain condition is met; in the basic implementation, this is just a programmable threshold which is continuously compared to the digitized input. More advanced algorithms (digital CFD, timing filters, etc.) are implemented in special DPP firmware. The individual channel self-trigger can be used to generate a global trigger for a simultaneous acquisition of all the channels within a board, can be propagated to the front panel connectors in order to make a multi-board triggering logic or can be used locally for an independent acquisition channel by channel (DPP mode only). It is also possible to combine the individual self-triggers to create a configurable coincidence or anticoincidence logic, either within the board or across multiple digitizers.

3. Scalability and synchronization of multi-board systems

In most cases, the applications that require the use of several channels need to synchronize the acquisition across different digitizers. This is performed according to the following points:

Distribution of a common clock reference in order to have the same sampling clock on all the ADC channels. CAEN digitizers feature a programmable PLL able to generate the sampling clocks locked to an external clock input, whose distribution can be done in parallel from a common source, using a fan-out, as well as through an in-out daisy chain with the ability to use the first board as a clock master (VME models only).

Alignment of the time stamp associated with the triggers to allow off-line reconstruction of the events read from different boards. This can be done by using an external signal as well as through an in-out daisy chain.

Distribution of the triggers from channel to channel and from board to board, according to a certain trigger logic. Each card has different trigger sources: external TRG-IN from the front panel, software trigger and channel self-triggers. All these triggers can be combined in order to make coincidences, majorities, global triggers and other functions.

4. High bandwidth data readout links

The digitizers are designed to provide high rate data transfer to a computer or an external data processing unit. CAEN digitizers have a bandwidth of $\approx 30\text{MB/s}$ in the case of the USB, about 80MB/s with CONET port up to more than 120MB/s for the VME with 2eSST.

The communication interfaces allow the user to operate post-processing data analysis.

5. Signal Digitization and Pulse Processing

The flash ADC technology has improved significantly in the last decades providing always higher resolution and faster sampling speed. The use of flash ADCs in acquisition boards gives the possibility to convert the analog signal preserving the information required by the experimental activities and the applications of nuclear techniques.

Digital acquisition devices described in this section represent multi-channel waveform digitizers providing time information and digitized signal waveforms through fast communication interfaces, allowing the user to operate post-processing data analysis.

The waveform digitizers integrate also field programmable gate arrays (FPGA) which are able to acquire the information from flash ADC in real time and process it. Algorithms can be programmed, and their parameters can be adjusted to different experimental conditions. Those algorithms may be the digital replacement of the traditional analog signal processing, so that the waveform digitizer embeds different functions in one single board. In particular, it is possible to replace timing filters such as Constant Fraction Discriminators, shaper amplifier, Peak Sensing ADC, QDC, TDC, etc.

Most of the algorithms are implemented at firmware level inside the FPGA, which also manages the overall acquisition and data transfer. Data is read by a software, which is able to both program the digitizer and to perform the acquisition. Most advanced software also provides specific analysis tool, such as peak fitting.

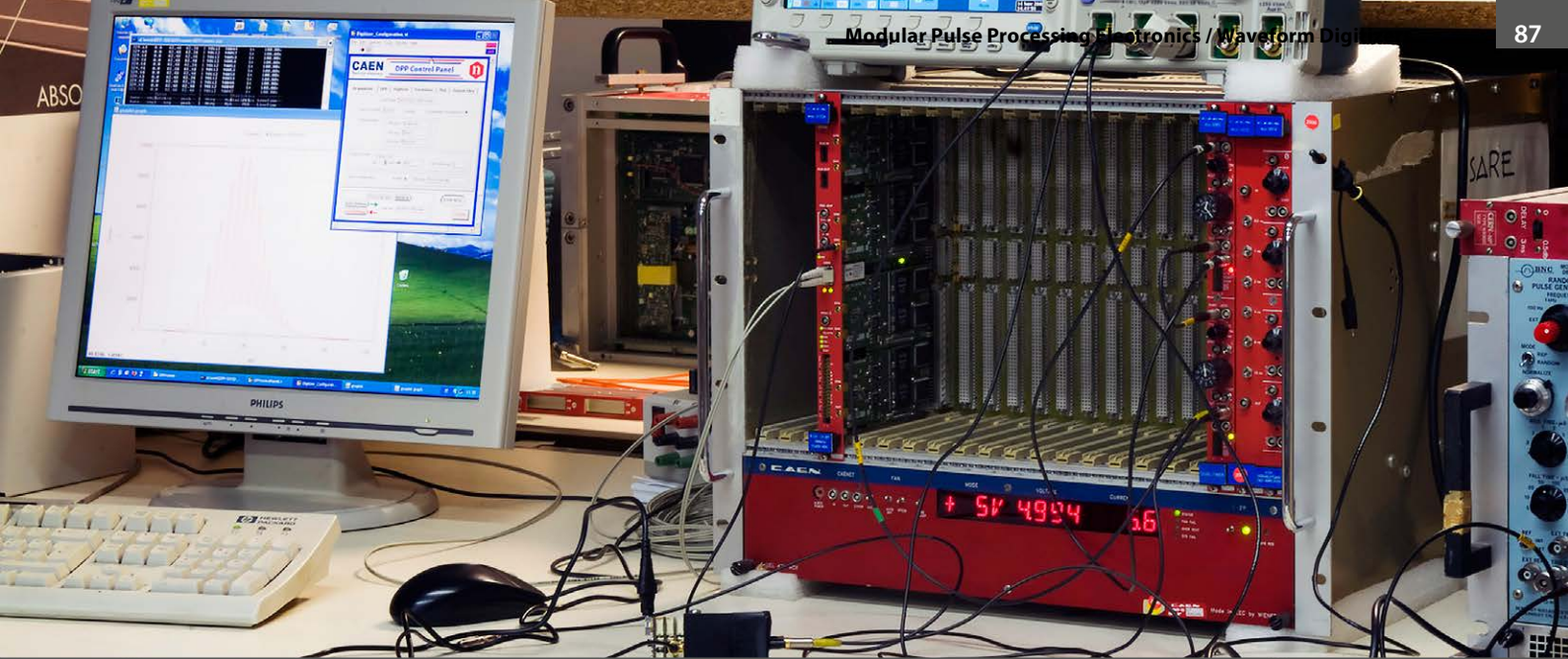

Introduction to Waveform Digitizers

Acquisition Modes

CAEN Digitizers can be operated in different acquisition modes which are introduced in the next sections:

1. Waveform Recording



The digitizer is able to acquire, digitalize and record the input pulse within a programmable time window. Simplified zero suppression functions can be configured. All CAEN digitizers are equipped with their proper default firmware for waveform recording. CAENScope and WaveDump software are available to manage the acquisition. Data can be saved in real time for offline analysis.

Furthermore, the 742 and 743 families, which come with two different switched capacitor chips, are well suitable for high precision time measurement of fast signals. WaveDump and the dedicated WaveCatcher software (free download) can control the acquisition of the two boards respectively.

2. Digital Pulse Processing (DPP)

Where the algorithm inside the FPGA not only acquires the waveform, but also performs additional processing to get a set of significant information like energy, pulse shape and precise timing.



Pulse Height Analysis for gamma ray spectroscopy applies to voltage signals coming from HPGe/Si detectors and Scintillators coupled with Charge Sensitive Preamplifiers.

Works with independent channels event acquisition and in time stamped list mode.

Energy spectra are built by the supported software like the new CoMPASS and MC²Analyzer.



Pulse Shape Discrimination for gated charge integration⁽¹⁾ and gamma-neutron discrimination is suited for current signals coming from Scintillators, Gas tubes, SiPM and PMT.

Works with independent channels event acquisition and in energy & timing list mode.

Features digital CFD and timing interpolation for high resolution time information, as well as pulse shape discrimination.

Energy spectra are built by the supported software like the new CoMPASS and the DPP-PSD Control Software.

(1) DPP-CI is no longer supported. To perform Charge Integration, please refer to the DPP-PSD.



Charge to Digital Conversion implements a Gated Integrator receiving signals directly from the detector (no charge preamp required).

Suited for Scintillators and Gas detectors with medium-slow decay time, but can also work with faster detectors such as LaBr₃.

Designed for high channel density digitizers, can be used for multi-channel acquisition in Detector Array systems.

Features independent channel acquisition with self-gating capability for the charge integration (no additional delay lines, no external discriminator).

Energy and time stamped list mode provides timing information as well as energy information for spectra calculation.



Zero Length Encoding for advanced zero suppression works with a common trigger and simultaneous acquisition on all channels. The digitized waveforms are transferred in compressed mode by suppressing baseline and empty channels.



Dynamic Acquisition Window is suited for zero suppression with trigger-less acquisition systems.

Works in waveform mode and independent channels event acquisition dynamically stretching the acquisition window (record length) to fit the actual input pulse duration.

Software Tools

CAEN provides drivers to integrate its boards in the host PC system, libraries and Demos for software custom development, and configuration software utilities.

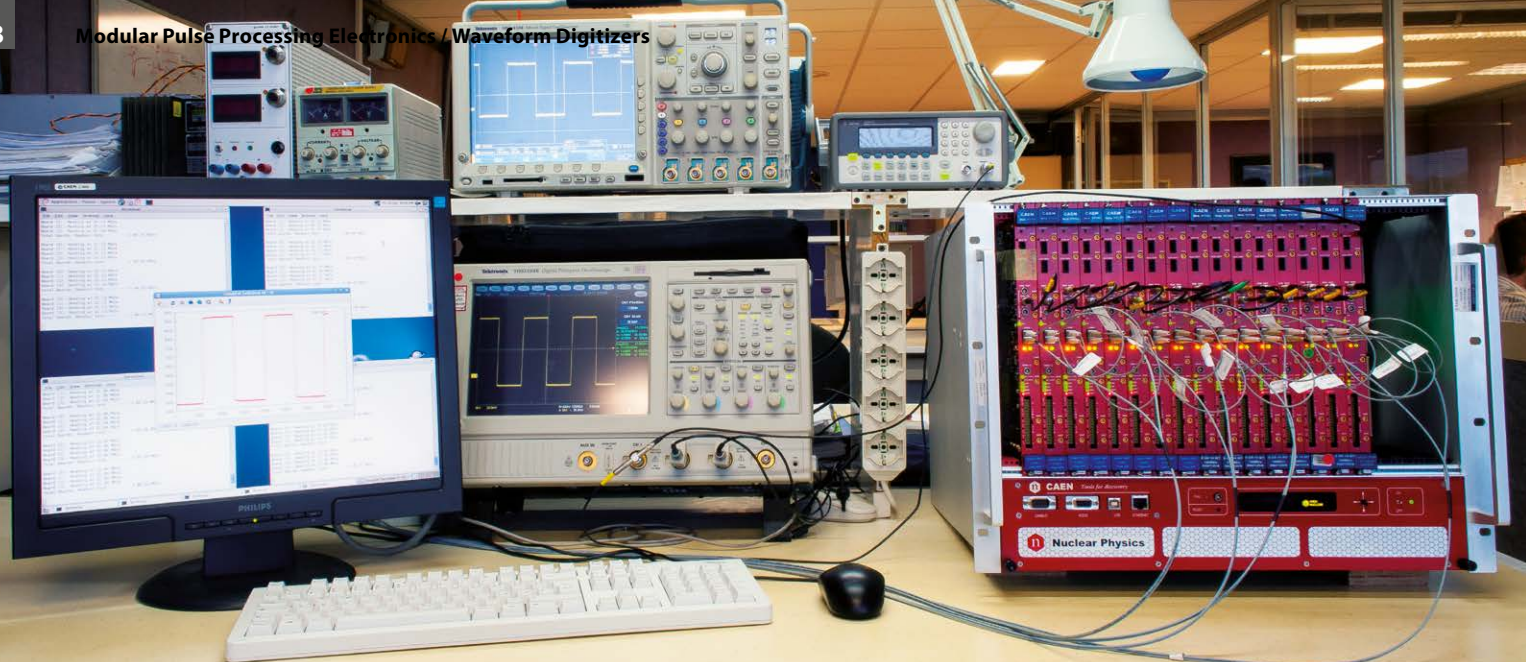

Introduction to Waveform Digitizers

Depending on the final purpose, the user can select the best fitting hardware and firmware solution with the supported CAEN software, as reported in the following table.

Type	Aquisition Mode	Features	Firmware ⁽¹⁾	Software ⁽²⁾	Family		
Digitizer	Digital Pulse Processing	Gated Charge Integration Pulse Shape Discrimination				x720 ⁽³⁾	
		Gated Charge Integration Pulse Shape Discrimination Constant Fraction Discriminator & Timing Interpolation				x725 x730 x751	
		Digital QDC Charge Integration				x740 ⁽⁶⁾	
		Pulse Height Analysis				x724 ⁽⁴⁾ x725 x730	
		Digital Waveform Recorder with Enhanced Zero Suppression				x725 ⁽⁵⁾ x730 ⁽⁵⁾ x751	
		Digital Waveform Recorder with Zero Suppression for trigger-less acquisition systems				x724	
		Waveform Recording	Digital Waveform Recorder				x742 x761
							x720 x724 x725 x730 x740 x751
							x743
	Digital Waveform Recorder Charge Integration Constant Fraction Discrimination					x743	

(1) DPP firmware: free trial version

Waveform Recording firmware (Default): free download

(2) Free Download

(3) DPP-CI firmware and DPP-CI Control Software are no longer supported. To perform Charge Integration please refer to the DPP-PSD firmware and software

(4) DPP-PHA, starting from rev. 128.64 of the AMC FPGA firmware, is no longer supported by x724 models equipped with EP1C4 Altera FPGA

(5) DPP-ZLE Plus for x725 and x730 families: Coming Soon

(6) CoMPASS software for DPP-QDC: Coming Soon

DPP-QDC firmware runs only on x740D digitizer models

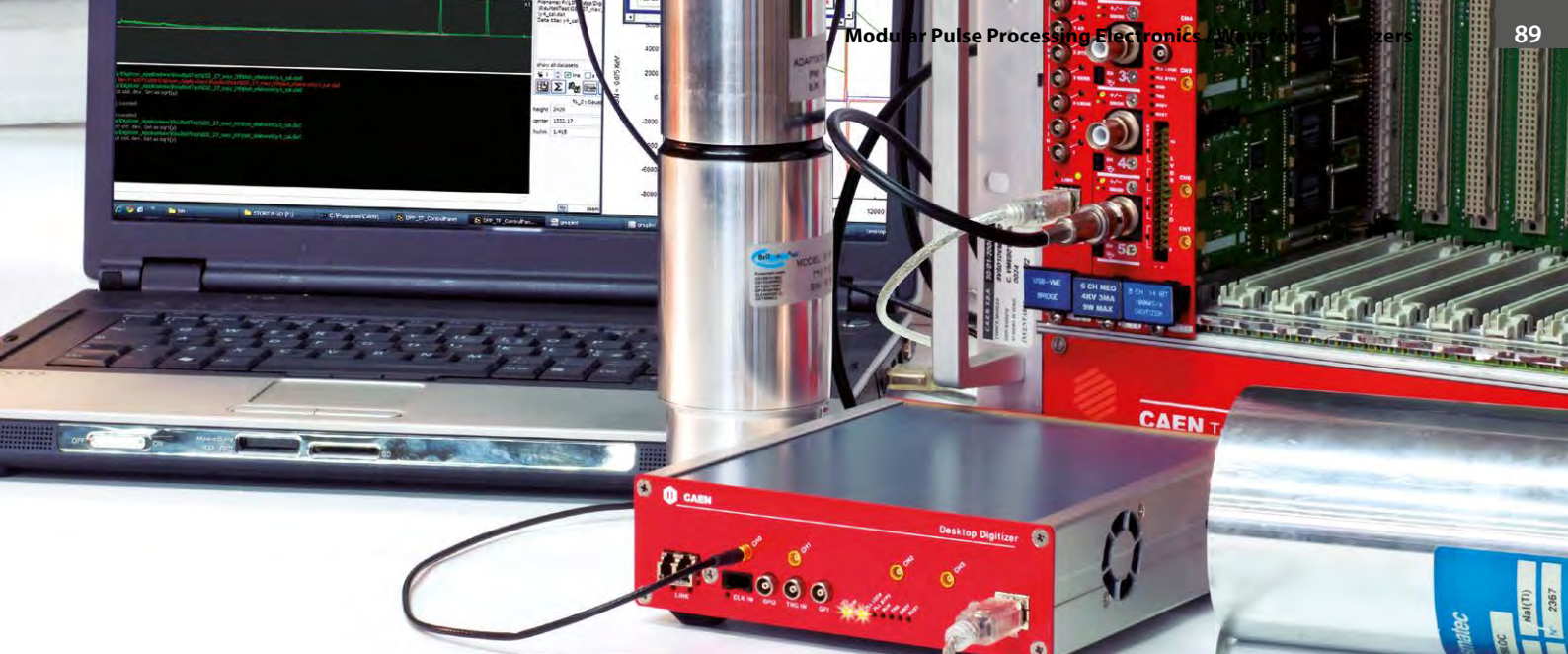

Introduction to Waveform Digitizers

Application Notes

CAEN provides a wide selection of application notes, white papers and scientific articles focused on digitizers and their use in different fields. In these documents, the capability and flexibility of CAEN digitizers are well exploited showing their physics-driven development.

Here follows a brief selection:

- AN2086 Synchronization of CAEN Digitizers in Multiple Board Acquisition Systems
- AN2503 Charge Integration: Analog Vs. Digital
- AN2506 Digital Gamma Neutron discrimination with Liquid Scintillators
- AN2508 CAEN Digital Pulse Height Analyser a digital approach to Radiation Spectroscopy
- AN2770 Digital ToF Measurements of Fast Neutrons in a Spallation Neutron Source
- WP2081 Digital Pulse Processing in Nuclear Physics
- AR2614 Tests of PMT Signal Read-out in a Liquid Argon Dark Matter Detector with a New Fast Waveform Digitizer
- AR2613 Special nuclear material detection with a mobile multi-detector system
- AR2612 First demonstration of a Compton gamma imager based on silicon photomultipliers
- AR2593 Diamond detectors for fast neutron measurements at pulsed spallation sources
- GD2827 How to make coincidences with CAEN digitizers
- AN3250 Pulse Shape Discrimination with different CAEN digitizers running DPP-PSD firmware
- AN3251 Time Measurements with CAEN Waveform Digitizers



All these documents are available for download in the Document Library section of CAEN website.

APPLICATIONS

- Nuclear and Particle Physics
- Dark Matter and Astroparticle Physics
- Fast Neutron spectroscopy, Fusion Plasma diagnostics
- Environmental monitoring, Homeland Security

FORM FACTOR

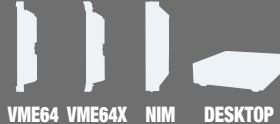

FEATURES

USB Digital I/O Optical Link

A cost-effective, general purpose choice

720 Digitizer Family

8/4/2 Ch. 12-bit 250 MS/s Digitizer

Overview

The 720 is a family of 12-bit and 250 MS/s Flash ADC Waveform Digitizers with 2 Vpp of input dynamic range and DC offset adjustment.





It is available in three form factors: VME (8 input channels), NIM (4 or 2 input channels) and Desktop (4 or 2 input channels).

Considering the sampling frequency and the bit number, these digitizers are well suited for mid-fast signals as the ones coming from liquid or inorganic scintillators coupled to PMTs or Silicon Photomultipliers.

The acquisition capabilities take advantage of the multi-buffer organization of the channel memory (divisible into a maximum of 1024 buffers). The data stream is continuously written in a circular memory buffer. When the trigger occurs, the digitizer writes further samples for the post trigger and freezes the buffer that can be read by one of the provided readout links. The acquisition can continue without any dead time in a new buffer. Two memory sizes are available according to the different versions of the x720 model: 1.25 MS/ch or 10 MS/ch.

The on-board FPGAs can run default firmware for waveform recording (including 'Zero suppression' and 'data reduction' methods that allow substantial savings in data amount readout and processing) as well as Digital Pulse Processing algorithms (DPP) making the digitizer an enhanced system for Physics applications. In addition to the existing firmware selection, CAEN is willing to collaborate with customers for developing custom solutions.

A common acquisition trigger signal can be provided externally, via front panel digital input connector, or via software. Alternatively, each channel can generate a trigger request when the input pulse goes under/over a programmable threshold; the trigger requests can be used either locally by the channel (independent triggering with DPP firmware) or processed by the board to generate a common trigger causing all the enable channels to acquire an event simultaneously

Firmware	Software	Features
		Digital Waveform Recording
		Charge Integration Pulse Shape Discrimination



(default firmware). The trigger from one board can be provided out on a front panel digital output connector.

720 family supports multi-board synchronization making a multi-board system where all ADCs result to be synchronized to a common clock source, and ensuring Trigger Time Tag alignment. Once synchronized, all data will be aligned and coherent across multiple x720 boards.

Features

- 12-bit @ 250 MS/s
- Analog inputs on MCX coax. connectors (single ended)
- VME64/VME64X (8 ch.), NIM (4 or 2 ch.) and Desktop (4 or 2 ch.) modules
- 2 Vpp input dynamic range with programmable DC offset adjustment
- Algorithms for Digital Pulse Processing (DPP)
- VME, USB and Optical Link communication interfaces
- Multi-board synchronization features
- Daisy chain capability
- Demo software tools, Control Software for default and DPP firmware, C and LabVIEW libraries

Technical Specifications

GENERAL

Form Factor

1-unit wide, 6U VME64/VME64X

1-unit wide NIM

154x50x164 mm³ (WxHxD) Desktop

ANALOG INPUT

Channels

8 channels, single ended (VME)

4/2 channels, single ended (NIM, Desktop)

Impedance

50 Ω

Connector

MCX

Full Scale Range (FSR)

2 V_{pp}

Bandwidth

125 MHz

Offset

Programmable DAC for DC offset adjustment. Range: ±1 V

DIGITAL CONVERSION

Resolution

12 bits

Sampling rate

31.25 to 250 MS/s simultaneously on each channel

ADC CLOCK GENERATION

Clock source: internal/external

On-Board PLL provides ADC sampling clock generation from an internal (50 MHz loc. oscillator) or external (front panel CLK-IN connector) reference

MEMORY

1.25 MS/ch or 10 MS/ch Multi Event Buffer with independent read and write access divisible into 1 ÷ 1024 buffers

Programmable event size and pre-post trigger

TRIGGER

Trigger sources

Self-trigger: channel over/under threshold for either Common or Individual (DPP firmware only) trigger generation

External-trigger: Common by TRG-IN or Individual by LVDS connectors (DPP firmware only)

Software-trigger: Common by software command

Trigger propagation

TRG-OUT (VME) / GPO (NIM and Desktop) digital output

Trigger Time Stamp

Default firmware: 31-bit counter, 16 ns resolution, 17 s range^(*); 48-bit extension by firmware

DPP-CI/PSD Firmware: 32-bit counter, 4 ns resolution, 17 s range; 64-bit extension by software

SYNCHRONIZATION

Clock propagation

Daisy chain (VME only) by CLK-IN/CLK-OUT connectors

One-to-many clock distribution from an external clock source

Clock Cable delay compensation

Acquisition Synchronization

Sync Start/Stop by digital I/O (S-IN, TRG-IN or GPI input, TRG-OUT or GPO output)

External Trigger Time Stamp reset

LVDS I/O (VME only)

16 general purpose LVDS I/Os controlled by FPGA

Busy, Data Ready, Memory full, Individual Trig-Out and other functions can be programmed

An Input Pattern from the LVDS I/Os can be associated to each trigger as an event marker

ANALOG MONITOR (VME only)

12-bit/100 MHz DAC FPGA controlled output with four operating modes: Trigger Majority / Test Pulses / Memory Occupancy / Voltage Level

COMMUNICATION INTERFACE

Optical Link

CAEN CONET proprietary protocol, up to 80 MB/s transfer rate

Daisy chainable: it is possible to connect up to 8/32 ADC modules to a single Optical Link Controller (Mod. A2818/A3818)

USB (NIM and Desktop direct, VME via V1718 bridge)

USB 2.0 compliant

Transfer rate up to 30 MB/s

VME

VME 64X compliant

Data transfer mode: BLT32, MBLT64 (70 MB/s using CAEN Bridge), CBLT32/64, 2eVME, 2eSST (up to 200 MB/s)

POWER CONSUMPTIONS

Desktop: 1.5 A @ 12 V (Typ.)

NIM: 2.9 A @ +6 V, 90 mA @ -6 V

VME: 4 A @ +5 V, 200 mA @ +12 V, 200 mA @ -12 V

Ordering Options

Code	Description	Form Factor
WDT5720BXAAA	DT5720B - 4 Ch. 12 bit 250 MS/s Digitizer: 1.25MS/ch, C20, SE	Desktop
WDT5720CXAAA	DT5720C - 2 Ch. 12 bit 250 MS/s Digitizer: 1.25MS/ch, C20, SE	Desktop
WDT5720DXAAA	DT5720D - 4 Ch. 12 bit 250 MS/s Digitizer: 10MS/ch, C20, SE	Desktop
WDT5720EXAAA	DT5720E - 2 Ch. 12 bit 250 MS/s Digitizer: 10MS/ch, C20, SE	Desktop
WN6720BXAAA	N6720B - 4 Ch. 12 bit 250 MS/s Digitizer: 1.25MS/ch, C20, SE	NIM
WN6720CXAAA	N6720C - 2 Ch. 12 bit 250 MS/s Digitizer: 1.25MS/ch, C20, SE	NIM
WN6720DXAAA	N6720D - 4 Ch. 12 bit 250 MS/s Digitizer: 10MS/ch, C20, SE	NIM
WN6720EXAAA	N6720E - 2 Ch. 12 bit 250 MS/s Digitizer: 10MS/ch, C20, SE	NIM
WV1720EXAAA	V1720E - 8 Ch. 12 bit 250 MS/s Digitizer: 1.25MS/ch, C20, SE	6U-VME64
WV1720GXAAA	V1720G - 8 Ch. 12 bit 250 MS/s Digitizer: 10MS/ch, C20, SE	6U-VME64
WVX1720EXAAA	VX1720E - 8 Ch. 12 bit 250 MS/s Digitizer: 1.25MS/ch, C20, SE	6U-VME64X
WVX1720GXAAA	VX1720G - 8 Ch. 12 bit 250 MS/s Digitizer: 10MS /ch, C20, SE	6U-VME64X
WFDPNPGAA20	DPP-PSD - Digital Pulse Processing for Pulse Shape Discrimination (x720)	ALL

Accessories

A2818
PCI CONET Controller



A3818
PCI Express CONET2 Controller



A654
MCX to LEMO Cable Adapter



A659
MCX to BNC Cable Adapter



A317
Clock Distribution Cable



A318
SE to Differential Clock Cable Adapter



AI2700
Optical Fiber Series



Cables for CONET Optical Link Networks

^(*) Trigger Logic and Trigger Time Stamp counter operate at 125 MHz (i.e. 8 ns or 1/2 ADC clock cycles), while the counter value is read at a frequency of 62.5 MHz (i.e. 16 ns).

APPLICATIONS

- Nuclear and Particle Physics
- X-ray and Gamma Spectroscopy with HPGe, Silicon detectors
- Spectroscopic Imaging for Homeland Security
- Segmented detectors, Medical Imaging, Material science

FORM FACTOR



FEATURES

USB Digital I/O Optical Link

Ideal for high resolution detectors

724 Digitizer Family

8/4/2 Ch. 14-bit 100 MS/s Digitizer

Overview

The 724 is a family of 14-bit and 100 MS/s Flash ADC Waveform Digitizers with 2.25 Vpp of input dynamics (optionally 0.5 or 10 Vpp) and DC offset adjustment.

It is available in three form factors: VME (8 input channels), NIM (4 or 2 input channels) and Desktop (4 or 2 input channels).

Considering the sampling frequency and the bit number, these digitizers are well suited for high resolution detectors as Silicon, HPGe coupled to Charge Sensitive Preamplifiers or inorganic scintillators like NaI or CsI.

The acquisition capabilities take advantage of the multi-buffer organization of the channel memory (divisible into a maximum of 1024 buffers). The data stream is continuously written in a circular memory buffer. When the trigger occurs, the digitizer writes further samples for the post trigger and freezes the buffer that can be read by one of the provided readout links. The acquisition can continue without any dead time in a new buffer. Two memory sizes are available according to the different versions of the x724 model: 512 kS/ch or 4 MS/ch.

The on-board FPGAs can run default firmware for waveform recording (including 'Zero suppression' and 'data reduction' methods that allow substantial savings in data amount readout and processing) as well as Digital Pulse Processing algorithms (DPP) making the digitizer an enhanced system for Physics applications. In addition to the existing firmware selection, CAEN is willing to collaborate with customers for developing custom solutions.

A common acquisition trigger signal can be provided externally, via front panel digital input connector, or via software. Alternatively, each channel can generate a trigger request when the input pulse goes









under/over a programmable threshold; the trigger requests can be used either locally by the channel (independent triggering with DPP firmware) or processed by the board to generate a common trigger causing all the enable channels to acquire an event simultaneously (default firmware). The trigger from one board can be provided on a front panel digital output connector.

724 family supports multi-board synchronization making a multi-board system where all ADCs result to be synchronized to a common clock source, and ensuring Trigger Time Tag alignment. Once synchronized, all data will be aligned and coherent across multiple x724 boards.

Features

- 14-bit @ 100 MS/s
- Analog inputs on MCX coax. connectors (single ended)
- VME64/VME64X (8 ch.), NIM (4 or 2 ch.) and Desktop (4 or 2 ch.) modules
- 0.5, 2.25 or 10 Vpp input dynamic range with programmable DC offset adjustment
- Algorithms for Digital Pulse Processing (DPP)
- VME, USB and Optical Link communication interfaces
- Multi-board synchronization features
- Daisy chain capability
- Demo software tools, Control Software for default and DPP firmware, C and LabVIEW libraries

Firmware	Software	Features
		Digital Waveform Recording
		Pulse Height Analysis
		Digital Waveform Recording with Zero Suppression for trigger-less acquisition systems

Technical Specifications

GENERAL

Form Factor

1-unit wide, 6U VME64/VME64X
1-unit wide NIM
154x50x164 mm³ (WxHxD) Desktop

ANALOG INPUT

Channels

8 channels, single ended (VME)
4/2 channels, single ended (NIM, Desktop)

Impedance

50 Ω (2.25 and 0.5 Vpp), 1 k Ω (10 Vpp)

Connector

MCX

Full Scale Range (FSR)

2.25 Vpp (0.5 or 10 Vpp by ordering code)

Bandwidth

40 MHz

Offset

Programmable DAC for DC offset adjustment. Range: ± 1.125 @ 2.25 Vpp, ± 0.25 @ 0.5 Vpp, ± 5 V @ 10 Vpp

DIGITAL CONVERSION

Resolution

14 bits

Sampling rate

32.2 to 100 MS/s simultaneously on each channel

ADC CLOCK GENERATION

Clock source: internal/external

On-Board PLL provides ADC sampling clock generation from an internal (50 MHz loc. oscillator) or external (front panel CLK-IN connector) reference

MEMORY

512 KS/ch or 4 MS/ch Multi-Event Buffer with independent read and write access divisible into $1 \div 1024$ buffers. Programmable event size and pre-post trigger

TRIGGER

Trigger sources

Self-trigger: channel over/under threshold for either Common or Individual (DPP firmware only) trigger generation

External-trigger: Common by TRG-IN or Individual by LVDS connectors (DPP firmware only)

Software-trigger: Common by software command

Trigger propagation

TRG-OUT (VME) / GPO (NIM and Desktop) digital output

Trigger Time Stamp

Default firmware: 31-bit counter, 20 ns resolution, 21 s range(*); 48-bit extension by firmware
DPP-PHA Firmware: 30-bit counter, 10 ns resolution, 10 s range; 64-bit extension by software
DPP-DAW Firmware: 31-bit counter, 10 ns resolution, 21 s range; 64-bit extension by software

SYNCHRONIZATION

Clock propagation

Daisy chain (VME only) through CLK-IN/CLK-OUT connectors

One-to-many clock distribution from an external clock source

Clock Cable delay compensation

Acquisition Synchronization

Acquisition Synchronization

Sync Start/Stop through digital I/O (S-IN, TRG-IN or GPI input, TRG-OUT or GPO output)

External Trigger Time Stamp reset

LVDS I/O (VME only)

16 general purpose LVDS I/Os controlled by FPGA

Busy, Data Ready, Memory full, Individual Trig-Out and other functions can be programmed

An Input Pattern from the LVDS I/Os can be associated to each trigger as an event marker

ANALOG MONITOR (VME only)

12-bit/100 MHz DAC FPGA controlled output with four operating modes: Trigger Majority / Test Pulses / Memory Occupancy / Voltage Level

COMMUNICATION INTERFACE

Optical Link

CAEN CONET proprietary protocol, up to 80 MB/s transfer rate

Daisy chainable: it is possible to connect up to 8/32 ADC modules to a single Optical Link Controller (Mod. A2818/A3818)

USB (NIM and Desktop direct, VME via V1718 bridge)

USB 2.0 compliant

Transfer rate up to 30 MB/s

VME

VME 64X compliant

Data transfer mode: BLT32, MBLT64 (70 MB/s using CAEN Bridge), CBLT32/64, 2eVME, 2eSST (up to 200 MB/s)

POWER CONSUMPTIONS

Desktop: 1.7 A @ 12 V (Typ.)

NIM: 3.9 A @ +6 V, 90 mA @ -6 V

VME: 4.5 A @ +5 V, 200 mA @ +12 V, 200 mA @ -12 V

(*) Trigger Logic and Trigger Time Stamp counter operate at 100 MHz (i.e. 10 ns or 1 ADC clock cycle), while the counter value is read at a frequency of 50 MHz (i.e. 20 ns).

Ordering Options

Code	Description	Form Factor
WDT5724BXAAA	DT5724B - 4 Ch. 14 bit 100 MS/s Digitizer: 512kS/ch, C20, SE	Desktop
WDT5724CXAAA	DT5724C - 2 Ch. 14 bit 100 MS/s Digitizer: 512kS/ch, C20, SE	Desktop
WDT5724FXAAA	DT5724F - 4 Ch. 14 bit 100 MS/s Digitizer: 4MS/ch, C20, SE	Desktop
WDT5724GXAAA	DT5724G - 2 Ch. 14 bit 100 MS/s Digitizer: 4MS/ch, C20, SE	Desktop
WN6724BXAAA	N6724B - 4 Ch. 14 bit 100 MS/s Digitizer: 512kS/ch, C20, SE	NIM
WN6724CXAAA	N6724C - 2 Ch. 14 bit 100 MS/s Digitizer: 512kS/ch, C20, SE	NIM
WN6724FXAAA	N6724F - 4 Ch. 14 bit 100 MS/s Digitizer: 4MS/ch, C20, SE	NIM
WN6724GXAAA	N6724G - 2 Ch. 14 bit 100 MS/s Digitizer: 4MS/ch, C20, SE	NIM
WV1724EXAAA	V1724E - 8 Ch. 14 bit 100 MS/s Digitizer: 4MS/ch, C20, SE	6U-VME64
WV1724GXAAA	V1724G - 8 Ch. 14 bit 100 MS/s Digitizer: 512kS/ch, C20, SE	6U-VME64
WVX1724EXAAA	VX1724E - 8 Ch. 14 bit 100 MS/s Digitizer: 4MS/ch, C20, SE	6U-VME64X
WPERS0172401	724 Customization - 10Vpp Input Range, SE	ALL
WPERS0172402	724 Customization - 500mVpp Input Range, SE	ALL
WFDPPPTFAAAA	DPP-PHA - Digital Pulse Processing for Pulse Height Analysis (x724)	ALL
WFDPPDAWAXEA	DPP-DAW - Digital Pulse Processing with Dynamic Acquisition Window (x724)	ALL

Accessories

A2818
PCI CONET Controller



A3818
PCI Express CONET2 Controller



A654
MCX to LEMO Cable Adapter



A659
MCX to BNC Cable Adapter



A317
Clock Distribution Cable



A318
SE to Differential Clock Cable Adapter



A12700
Optical Fiber Series



Cables for CONET Optical Link Networks

APPLICATIONS

- Nuclear and Particle Physics
- Dark Matter and Astroparticle Physics
- Fast Neutron spectroscopy
- Homeland Security

FORM FACTOR

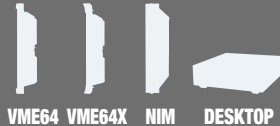

FEATURES

USB Digital I/O Optical Link

Maximum flexibility

NEW

725 Digitizer Family

16/8 Ch. 14-bit 250 MS/s Digitizer

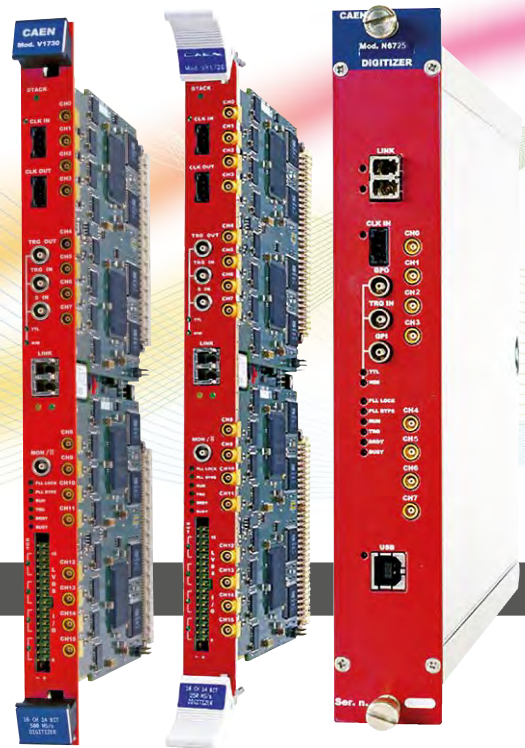

Overview

The 725 is a family of 14-bit and 250 MS/s Flash ADC Waveform Digitizers with software selectable 0.5 Vpp or 2 Vpp (default) input dynamic range and DC offset adjustment.

It is available in three form factors: VME (16/8 input channels), NIM (8 input channels) and Desktop (8 input channels).

Considering the sampling frequency and the bit number, these digitizers are well suited for mid-fast signals as the ones coming from liquid or inorganic scintillators coupled to PMTs or Silicon Photomultipliers, and others.

The acquisition capabilities take advantage of the multi-buffer organization of the channel memory (divisible into a maximum of 1024 buffers). The data stream is continuously written in a circular memory buffer. When the trigger occurs, the digitizer writes further samples for the post trigger and freezes the buffer that can be read by one of the provided readout links. The acquisition can continue without any dead time in a new buffer. Two memory sizes are available according to the different versions of the x725 model: 640 kS/ch or 5.12 MS/ch.

The on-board FPGAs can run default firmware for waveform recording as well as Digital Pulse Processing algorithms (DPP) making the digitizer an enhanced system for Physics applications. In addition to the existing firmware selection, CAEN is willing to collaborate with customers for developing custom solutions.

A common acquisition trigger signal can be provided externally, via front panel digital input connector, or via software. Alternatively, each



channel can generate a trigger request when the input pulse goes under/over a programmable threshold; the trigger requests can be used either locally by the channel (independent triggering with DPP firmware) or processed by the board to generate a common trigger causing all the enable channels to acquire an event simultaneously (default firmware). The trigger from one board can be provided on a front panel digital output connector.

725 family supports multi-board synchronization making a multi-board system where all ADCs result to be synchronized to a common clock source, and ensuring Trigger Time Tag alignment. Once synchronized, all data will be aligned and coherent across multiple x725 boards.

Firmware	Software	Features
		Digital Waveform Recording
		Charge Integration Pulse Shape Discrimination Constant Fraction Discriminator
		Pulse Height Analysis
		Digital Waveform Recording with Enhanced Zero Suppression
Coming soon		

Features

- 14-bit @ 250 MS/s
- Analog inputs on MCX coax. connectors
- VME64/VME64X (16/8 ch.), NIM (8 ch.) and Desktop (8 ch.) modules
- 0.5 and 2 Vpp input dynamic range with programmable DC offset adjustment
- Algorithms for Digital Pulse Processing (DPP)
- VME, USB and Optical Link communication interfaces
- Multi-board synchronization features
- Daisy chain capability
- Demo software tools, Control Software for default and DPP firmware, C and LabVIEW libraries

Technical Specifications

GENERAL

Form Factor
1-unit wide, 6U VME64/VME64X
1-unit wide NIM
154x50x164 mm³ (WxHxD) Desktop

ANALOG INPUT

Channels
16/8 channels, single ended (VME)
8 channels, single ended (NIM, Desktop)

Impedance

50 Ω

Connector

MCX

Full Scale Range (FSR)

0.5 or 2 V_{pp} (default) software selectable

Bandwidth

125 MHz

Offset

Programmable DAC for DC offset adjustment. Range: ± 1 V @ 2 V_{pp}, ± 0.25 V @ 0.5 V_{pp}

DIGITAL CONVERSION

Resolution

14 bits

Sampling rate

250 MS/s simultaneously on each channel

ADC CLOCK GENERATION

Clock source: internal/external

On-Board PLL provides ADC sampling clock generation from an internal (50 MHz loc. oscillator) or external (front panel CLK-IN connector) reference

MEMORY

640 kS/ch or 5.12 MS/ch Multi-Event Buffer with independent read and write access divisible into 1 ÷ 1024 buffers. Programmable event size and pre-post trigger

TRIGGER

Trigger source

Self-trigger: channel over/under threshold for either Common or Individual (DPP firmware only) trigger generation

External-trigger: Common by TRG-IN or Individual by LVDS connectors (DPP firmware only)

Software-trigger: Common by software command

Trigger propagation

TRG-OUT (VME) / GPO (NIM, Desktop) digital output

Trigger Time Stamp

Default Firmware: 31-bit counter, 16 ns resolution, 17 s range(*); 48-bit extension by firmware
DPP-PHA/PSD: 31-bit counter, 4 ns resolution, 8 s range; 47-bit extension by firmware; 10-bit and 4 ps fine time stamp by digital CFD; 64-bit extension by software

SYNCHRONIZATION

Clock propagation

Daisy chain (VME only) through CLK-IN/CLK-OUT connectors

One-to-many clock distribution from an external clock source

Clock Cable delay compensation

Acquisition Synchronization

Sync Start/Stop through digital I/O (S-IN, TRG-IN or GPI input, TRG-OUT or GPO output)

External Trigger Time Stamp reset

LVDS I/O (VME only)

16 general purpose LVDS I/Os controlled by FPGA

Busy, Data Ready, Memory Full, Individual Trg-Out and other functions can be programmed
An Input Pattern from the LVDS I/Os can be associated to each trigger as an event marker

ANALOG MONITOR (VME only)

12-bit/100 MHz DAC FPGA controlled output with four operating modes:

Trigger Majority / Test Pulses / Memory Occupancy / Voltage Level

COMMUNICATION INTERFACE

Optical Link

CAEN CONET proprietary protocol,

up to 80 MB/s transfer rate

Daisy chainable: it is possible to connect up to 8/32 ADC modules to a single Optical Link Controller (Mod.A2818/A3818)

VME

VME 64X compliant

Data transfer mode: BLT32, MBLT64 (70 MB/s using CAEN Bridge), CBLT32/64, 2eVME, 2eSST (up to 200 MB/s)

POWER CONSUMPTIONS

Desktop: TBD

NIM: TBD

VME: V1725	V1725x
5.2 A @ +5 V	TBD
750 mA @ +12 V	
-12 V not used	

Ordering Options

Code	Description	Form Factor
WDT5725XAAA	DT5725 - 8 Ch. 14 bit 250 MS/s Digitizer: 640kS/ch, CE30, SE	Desktop
WDT5725BXAAA	DT5725B - 8 Ch. 14 bit 250 MS/s Digitizer: 5.12MS/ch, CE30, SE	Desktop
WN6725XAAA	N6725 - 8 Ch. 12/14 bit 500 MS/s Digitizer: 640kS/ch, CE30, SE	NIM
WN6725BXAAA	N6725B - 8 Ch. 12/14 bit 500 MS/s Digitizer: 5.12MS/ch, CE30, SE	NIM
WV1725XAAA	V1725 - 16 Ch. 14 bit 250 MS/s Digitizer: 640kS/ch, CE30, SE	6U-VME64
WV1725BXAAA	V1725B - 16 Ch. 14 bit 250 MS/s Digitizer: 5.12MS/ch, CE30, SE	6U-VME64
WV1725CXAAA	V1725C - 8 Ch. 14 bit 250 MS/s Digitizer: 640kS/ch, CE30, SE	6U-VME64
WV1725DXAAA	V1725D - 8 Ch. 14 bit 250 MS/s Digitizer: 5.12MS/ch, CE30, SE	6U-VME64
WVX1725XAAA	VX1725 - 16 Ch. 14 bit 250 MS/s Digitizer: 640kS/ch, CE30, SE	6U-VME64X
WVX1725BXAAA	VX1725B - 16 Ch. 14 bit 250 MS/s Digitizer: 5.12MSch, CE30, SE	6U-VME64X
WVX1725CXAAA	VX1725C - 8 Ch. 14 bit 250 MS/s Digitizer: 640kS/c, CE30, SE	6U-VME64X
WVX1725DXAAA	VX1725D - 8 Ch. 14 bit 250 MS/s Digitizer: 5.12MS/ch, CE30, SE	6U-VME64X
WFDPPPTFAA25	DPP-PHA - Digital Pulse Processing for Pulse Height Analysis (x725)	ALL
WFDPPPNGAA25	DPP-PSD - Digital Pulse Processing for Pulse Shape Discrimination (x725)	ALL

Accessories

A2818
PCI CONET Controller



A3818
PCI Express CONET2 Controller



A654
MCX to LEMO Cable Adapter



A659
MCX to BNC Cable Adapter



A317
Clock Distribution Cable



A318
SE to Differential Clock Cable Adapter



A12700
Optical Fiber Series



Cables for CONET Optical Link Networks

(*) Trigger Logic and Trigger Time Stamp counter operate at 125 MHz (i.e. 8 ns or 2 ADC clock cycles), while the counter value is read at a frequency of 62.5 MHz (i.e. 16 ns).

APPLICATIONS

- Nuclear and Particle Physics
- Dark Matter and Astroparticle Physics
- Fast Neutron spectroscopy
- Homeland Security

FORM FACTOR

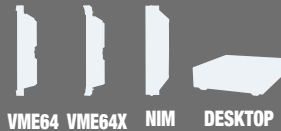

FEATURES

- USB
- Digital I/O
- Optical Link

Excellent resolution and fast sampling combined



730 Digitizer Family

16/8 Ch. 14-bit 500 MS/s Digitizer

Overview

The 730 is a family of 14-bit and 500 MS/s Flash ADC Waveform Digitizers with software selectable 0.5 Vpp or 2 Vpp (default) input dynamic range and DC offset adjustment.

It is available in three form factors: VME (16/8 input channels), NIM (8 input channels) and Desktop (8 input channels).

Considering the sampling frequency and the bit number, these digitizers are well suited for mid-fast signals as the ones coming from liquid or inorganic scintillators coupled to PMTs or Silicon Photomultipliers, and others.

The acquisition capabilities take advantage of the multi-buffer organization of the channel memory (divisible into a maximum of 1024 buffers). The data stream is continuously written in a circular memory buffer. When the trigger occurs, the digitizer writes further samples for the post trigger and freezes the buffer that can be read by one of the provided readout links. The acquisition can continue without any dead time in a new buffer. Two memory sizes are available according to the different versions of the x730 model: 640 kS/ch or 5.12 MS/ch.

The on-board FPGAs can run default firmware for waveform recording as well as Digital Pulse Processing algorithms (DPP) making the digitizer an enhanced system for Physics applications. In addition to the existing firmware selection, CAEN is willing to collaborate with customers for developing custom solutions.

A common acquisition trigger signal can be provided externally, via front panel digital input connector, or via software. Alternatively, each



channel can generate a trigger request when the input pulse goes under/over a programmable threshold; the trigger requests can be used either locally by the channel (independent triggering with DPP firmware) or processed by the board to generate a common trigger causing all the enable channels to acquire an event simultaneously (default firmware). The trigger from one board can be provided out on a front panel digital output connector.

730 family supports multi-board synchronization making a multi-board system where all ADCs result to be synchronized to a common clock source, and ensuring Trigger Time Tag alignment. Once synchronized, all data will be aligned and coherent across multiple x730 boards.

Features

- 14-bit @ 500 MS/s
- Analog inputs on MCX coax. connectors
- VME64/VME64X (16/8 ch.), NIM (8 ch.) and Desktop (8 ch.) modules
- 0.5 and 2 Vpp input dynamic range with programmable DC offset adjustment
- Algorithms for Digital Pulse Processing (DPP)
- VME, USB and Optical Link communication interfaces
- Multi-board synchronization features
- Daisy chain capability
- Demo software tools, Control Software for default and DPP firmware, C and LabVIEW libraries

Firmware	Software	Features
		Digital Waveform Recording
		Charge Integration Pulse Shape Discrimination Constant Fraction Discriminator
		Pulse Height Analysis
		Digital Waveform Recording with Enhanced Zero Suppression
Coming soon		

Technical Specifications

GENERAL

Form Factor
1-unit wide, 6U VME64/VME64X
1-unit wide NIM
154x50x164 mm³ (WxHxD) Desktop

ANALOG INPUT

Channels
16/8 channels, single ended (VME)
8 channels, single ended (NIM, Desktop)

Impedance

50 Ω

Connector

MCX

Full Scale Range (FSR)

0.5 or 2 Vpp (default) software selectable

Bandwidth

250 MHz

Offset

Programmable DAC for DC offset adjustment. Range: ± 1 V @ 2 Vpp, ± 0.25 V @ 0.5 Vpp

DIGITAL CONVERSION

Resolution

14 bits

Sampling rate

500 MS/s simultaneously on each channel

ADC CLOCK GENERATION

Clock source: internal/external

On-Board PLL provides ADC sampling clock generation from an internal (50 MHz loc. oscillator) or external (front panel CLK-IN connector) reference

MEMORY

640 kS/ch or 5.12 MS/ch Multi-Event Buffer with independent read and write access divisible into $1 \div 1024$ buffers. Programmable event size and pre-post trigger

TRIGGER

Trigger source

Self-trigger: channel over/under threshold for either Common or Individual (DPP firmware only) trigger generation

External-trigger: Common by TRG-IN or Individual by LVDS connectors (DPP firmware only)

Software-trigger: Common by software command

Trigger propagation

TRG-OUT (VME) / GPO (NIM, Desktop) digital output

Trigger Time Stamp

Default Firmware: 31-bit counter, 16 ns resolution, 17 s range^(*); 48-bit extension by firmware
DPP-PHA/PSD: 31-bit counter, 2 ns resolution, 4 s range; 47-bit extension by firmware; 10-bit and 2 ps fine time stamp by digital CFD; 64-bit extension by software

SYNCHRONIZATION

Clock propagation

Daisy chain (VME only) through CLK-IN/CLK-OUT connectors

One-to-many clock distribution from an external clock source

Clock Cable delay compensation

Acquisition Synchronization

Sync Start/Stop through digital I/O (S-IN, TRG-IN or GPI input, TRG-OUT or GPO output)

External Trigger Time Stamp reset

LVDS I/O (VME only)

16 general purpose LVDS I/Os controlled by FPGA

Busy, Data Ready, Memory full, Individual Trig-Out and other functions can be programmed

An Input Pattern from the LVDS I/Os can be associated to each trigger as an event marker

ANALOG MONITOR (VME only)

12-bit/100 MHz DAC FPGA controlled output with four operating modes: Trigger Majority / Test Pulses / Memory Occupancy / Voltage Level

COMMUNICATION INTERFACE

Optical Link

CAEN CONET proprietary protocol, up to 80 MB/s transfer rate

Daisy chainable: it is possible to connect up to 8/32 ADC modules to a single Optical Link Controller (Mod. A2818/A3818)

USB (NIM and Desktop direct, VME via V1718 bridge)

USB 2.0 compliant

Transfer rate up to 30 MB/s

VME

VME 64X compliant

Data transfer mode: BLT32, MBLT64 (70 MB/s using CAEN Bridge), CBLT32/64, 2eVME, 2eSST (up to 200 MB/s)

POWER CONSUMPTIONS

Desktop: 2.8 A @ 12 V (Typ.)

NIM: 4.9 @ +6 V, 250 mA @ -6 V

VME: V1730	V1730B	V1730x
8.2 A @ +5 V	10.2 A @ +5 V	TBD
840 mA @ +12 V	840 mA @ +12 V	
-12 V not used	-12 V not used	

Ordering Options

Code	Description	Form Factor
WDT5730XAAAA	DT5730 - 8 Ch. 14 bit 500 MS/s Digitizer: 640kS/ch, CE30, SE	Desktop
WDT5730BXAAA	DT5730B - 8 Ch. 14 bit 500 MS/s Digitizer: 5.12MS/ch, CE30, SE	Desktop
WN6730XAAAA	N6730 - 8 Ch. 14 bit 500 MS/s Digitizer: 640kS/ch, CE30, SE	NIM
WN6730BXAAAA	N6730B - 8 Ch. 14 bit 500 MS/s Digitizer: 5.12MS/ch, CE30, SE	NIM
WV1730XAAAA	V1730 - 16 Ch. 14 bit 500 MS/s Digitizer: 640kS/ch, CE30, SE	6U-VME64
WV1730BXAAAA	V1730B - 16 Ch. 14 bit 500 MS/s Digitizer: 5.12MS/ch, CE30, SE	6U-VME64
WV1730CXAAAA	V1730C - 8 Ch. 14 bit 500 MS/s Digitizer: 640kS/ch, CE30, SE	6U-VME64
WV1730DXAAAA	V1730D - 8 Ch. 14 bit 500 MS/s Digitizer: 5.12MS/ch, CE30, SE	6U-VME64
WVX1730XAAAA	VX1730 - 16 Ch. 14 bit 500 MS/s Digitizer: 640kS/ch, CE30, SE	6U-VME64X
WVX1730BXAAA	VX1730B - 16 Ch. 14 bit 500 MS/s Digitizer: 5.12MS/ch, CE30, SE	6U-VME64X
WVX1730CXAAA	VX1730C - 8 Ch. 14 bit 500 MS/s Digitizer: 640kS/ch, CE30, SE	6U-VME64X
WVX1730DXAAA	VX1730D - 8 Ch. 14 bit 500 MS/s Digitizer: 5.12MS/ch, CE30, SE	6U-VME64X
WFDPPPTFAA30	DPP-PHA - Digital Pulse Processing for Pulse Height Analysis (x730)	ALL
WFDPPPNGAA30	DPP-PSD - Digital Pulse Processing for Pulse Shape Discrimination (x730)	ALL

Accessories

A2818

PCI CONET Controller



A3818

PCI Express CONET2 Controller



A654

MCX to LEMO Cable Adapter



A659

MCX to BNC Cable Adapter



A317

Clock Distribution Cable



A318

SE to Differential Clock Cable Adapter



AI2700

Optical Fiber Series



Cables for CONET Optical Link Networks

^(*) Trigger Logic and Trigger Time Stamp counter operate at 125 MHz (i.e. 8 ns or 4 ADC clock cycles), while the counter value is read at a frequency of 62.5 MHz (i.e. 16 ns).

APPLICATIONS

- Nuclear and Particle Physics
- Neutrino Physics
- Spectroscopic Imaging
- Homeland Security

FORM FACTOR



VME64 VME64X NIM DESKTOP

FEATURES

USB Digital I/O Optical Link

Very high channel density



740 Digitizer Family

64/32 Ch. 12-bit 62.5 MS/s Digitizer

Overview

The 740 is a family of 12-bit and 62.5 MS/s Flash ADC Waveform Digitizers with 2 Vpp (optionally 10 Vpp) of input dynamic range and DC offset adjustment. It is available in three form factors: VME (64 input channels), NIM (32 input channels) and Desktop (32 input channels). Such a high channel density, thanks to an octal ADC chip, implies that most channel settings are common to groups of 8 channels (one group per ADC chip).

Considering the sampling frequency and the bit number, these digitizers are well suited for mid-slow signals as the ones coming from inorganic scintillators coupled to PMTs, gaseous detectors and others. Sampling rate can be reduced thanks to the firmware decimation option.

The acquisition capabilities take advantage of the multi-buffer organization of the channel memory (divisible into a maximum of 1024 buffers). The data stream is continuously written in a circular memory buffer. When the trigger occurs, the digitizer writes further samples for the post trigger and freezes the buffer that can be read by one of the provided readout links. The acquisition can continue without any dead time in a new buffer. Two memory sizes are available according to the different versions of the x740 model: 192 kS/ch or 1.5 MS/ch.

The On-board FPGAs can run default firmware for waveform recording as well as Digital Pulse Processing algorithms (DPP) making the digitizer an enhanced system for Physics application. Special DPP-QDC firmware is supported by x740D digitizer models. In addition to the existing firmware selection, CAEN is willing to collaborate with customers for developing custom solutions.

A common acquisition trigger signal can be provided externally, via front panel digital input connector, or via software. Alternatively, in the









default firmware, each 8-channel group can generate a trigger request when at least one of the channels goes under/over a programmable threshold; the requests from the groups are processed by the board to generate a common trigger causing all the channels to acquire an event simultaneously. In the DPP firmware each channel can trigger the event acquisition independently on the others upon the pulse under/over threshold. The trigger from one board can be provided on a front panel digital output connector.

740 family supports multi-board synchronization making a multi-board system where all ADCs result to be synchronized to a common clock source, and ensuring Trigger Time Tag alignment. Once synchronized, all data will be aligned and coherent across multiple x740 boards.

Features

- 12-bit @ 62.5 MS/s
- Analog inputs on ERNI SMC connectors
- VME64/VME64X (64 ch.), NIM (32 ch.) and Desktop (32 ch.) modules
- 2 or 10 Vpp input dynamic range with programmable DC offset adj.
- Sampling rate decimation factor (software selectable)
- Algorithms for Digital Pulse Processing (DPP)
- VME, USB and Optical Link communication interfaces
- Multi-board synchronization features
- Daisy chain capability
- Demo software tools, Control Software for default and DPP firmware, C and LabVIEW libraries

(1) DPP-QDC firmware runs only on x740D digitizer models

Firmware	Software	Features
	 	Digital Waveform Recording
	 	Digital QDC Charge Integration (1)

Technical Specifications

GENERAL

Form Factor

1-unit wide, 6U VME64/VME64X
1-unit wide NIM
154x50x164 mm³ (WxHxD) Desktop

ANALOG INPUT

Channels

64 channels, single ended (VME); 32 channels, single ended (NIM)
32 channels, single ended (Desktop) or 16 channels by auxiliary on-board connectors

Impedance

50 Ω (2 Vpp), 1 k Ω (10 Vpp)

Connector

ERNI SMC Dual Row 68pin (VME, NIM and Desktop)

MCX auxiliary (Desktop)

Full Scale Range (FSR)

2 or 10 Vpp (by ordering code)

Bandwidth

30 MHz

Offset

Programmable DAC for DC offset adjustment per each 8-channel group

Range: ±1 V @ 2 Vpp, ±5 V @ 10 Vpp

DIGITAL CONVERSION

Resolution

12 bits

Sampling rate

62.5 MS/s simultaneously on each channel (65 MS/s using external clock)
Down to 62.5/128 MS/s by programmable decimation factor ($62.5/2^n$ MS/s; $n=0,\dots,7$)

ADC CLOCK GENERATION

Clock source: internal/external

On-Board PLL provides ADC sampling clock generation from an internal (50 MHz loc. oscillator) or external (front panel CLK-IN connector) reference

MEMORY

192 kS/ch or 1.5 MS/ch Multi-Event Buffer with independent read and write access divisible into $1 \div 1024$ buffers. Programmable event size and pre-post trigger

TRIGGER

Trigger sources

Self-trigger: channel over/under threshold for either Common or Individual (DPP firmware only) trigger generation

External-trigger: Common by TRG-IN or Individual by LVDS connectors (DPP firmware only)

Software-trigger: Common by software command

Trigger propagation

TRG-OUT (VME) / GPO (NIM and Desktop) digital output

Trigger Time Stamp

Default firmware: 31-bit counter, 16 ns resolution, 17 s range(*); 48-bit extension by firmware

DPP-QDC Firmware: 32-bit counter, 16 ns resolution, 68 s range; 48-bit extension by firmware; 64-bit extension by software

SYNCHRONIZATION

Clock propagation

Daisy chain (VME only) through CLK-IN/CLK-OUT connectors

One-to-many clock distribution from an external clock source

Clock Cable delay compensation

Acquisition Synchronization

Sync Start/Stop through digital I/O (S-IN, TRG-IN or GPI input, TRG-OUT or GPO output)

External Trigger Time Stamp reset

LVDS I/O (VME only)

16 general purpose LVDS I/Os controlled by FPGA

Busy, Data Ready, Memory full, Individual Trig-Out and other functions can be programmed An Input Pattern from the LVDS I/Os can be associated to each trigger as an event marker

ANALOG MONITOR (VME only)

12-bit/100 MHz DAC FPGA controlled output with four operating modes: Trigger Majority / Test Pulses / Memory Occupancy / Voltage Level

COMMUNICATION INTERFACE

Optical Link

CAEN CONET proprietary protocol, up to 80 MB/s transfer rate

Daisy chainable: it is possible to connect up to 8/32 ADC modules to a single Optical Link Controller (Mod. A2818/A3818)

USB (NIM and Desktop direct, VME via V1718 bridge)

USB 2.0 compliant

Transfer rate up to 30 MB/s

VME

Data transfer mode: BLT32, MBLT64 (70 MB/s using CAEN Bridge), CBLT32/64, 2eVME, 2eSST (up to 200 MB/s)

POWER CONSUMPTIONS

Desktop: 1.9 A @ 12 V (Typ.)

NIM: 3.9 A @ +6 V, 490 mA @ -6 V

VME: 5.6 A @ +5 V, 250 mA @ +12 V, -12 V not used

(*) Trigger Logic and Trigger Time Stamp counter operate at 125 MHz (i.e. 8 ns or 1/2 ADC clock cycles), while the counter value is read at a frequency of 62.5 MHz (i.e. 16 ns).

Ordering Options

Code	Description	Form Factor
WDT5740XAAAA	DT5740 - 32 Ch. 12 bit 62.5 MS/s Digitizer: 192kS/ch, EP3C16, SE	Desktop
WDT5740CXAAA	DT5740C - 10Vpp input 32 Ch. 12 bit 62.5MS/s Digitizer: 192kS/ch, EP3C16, SE	Desktop
WDT5740DXAAA	DT5740D - 32 Ch. 12 bit 62.5 MS/s Digitizer: 192kSch, EP3C40, SE	Desktop
WN6740DXAAAA	N6740D - 32 Ch. 12 bit 62.5 MS/s Digitizer: 192kS/ch, EP3C40, SE	NIM
WN6740XAAAAA	N6740 - 32 Ch. 12 bit 62.5 MS/s Digitizer: 192kS/ch, EP3C16, SE	NIM
WN6740CXAAAA	N6740C - 10Vpp input 32 Ch. 12 bit 62.5 MS/s Digitizer: 192kS/ch, EP3C16, SE	NIM
WV1740XAAAAA	V1740 - 64 Ch. 12 bit 62.5 MS/s Digitizer: 192kS/ch, EP3C16, SE	6U-VME64
WV1740AXAAAA	V1740A - 10Vpp input 64ch 12bit 62.5MS/s Digitizer: 1.5 MS/ch, EP3C16, SE	6U-VME64
WV1740BXAAAA	V1740B - 64 Ch. 12 bit 62.5 MS/s Digitizer: 1.5 MS/ch, EP3C16, SE	6U-VME64
WV1740CXAAAA	V1740C - 10Vpp input 64ch 12bit 62.5MS/s Digitizer: 192kS/ch, EP3C16, SE	6U-VME64
WV1740DXAAAA	V1740D - 64 Ch. 12 bit 62.5 MS/s Digitizer: 192kS/ch, EP3C40, SE	6U-VME64
WVX1740XAAAA	VX1740 - 64 Ch. 12 bit 62.5 MS/s Digitizer: 192kS/ch, EP3C16, SE	6U-VME64X
WVX1740AXAAA	VX1740A - 10Vpp input 64 Ch. 12 bit 62.5 MS/s Digitizer: 1.5 MS/ch, EP3C16, SE	6U-VME64X
WVX1740BXAAA	VX1740B - 64 Ch. 12 bit 62.5 MS/s Digitizer: 1.5 MS/ch, EP3C16, SE	6U-VME64X
WVX1740CXAAA	VX1740C - 10Vpp input 64 Ch. 12 bit 62.5 MS/s Digitizer: 192 KS/ch, EP3C16, SE	6U-VME64X
WVX1740DXAAA	VX1740D - 64 Ch. 12 bit 62.5 MS/s Digitizer: 192kSch, EP3C40, SE	6U-VME64X
WFWDDPPQDCAA	DPP-QDC-Digital Pulse Processing for Time Stamped Digital QDC (x740)	ALL

Accessories

A746D

32 Channel Adapter for LEMO connector



A746B

64 Channel Adapter for LEMO connector



A746B

64 Channel Adapter for LEMO connector



A2818

PCI CONET Controller



A3818

PCI Express CONET2 Controller



A654

MCX to LEMO Cable Adapter



A659

MCX to BNC Cable Adapter



A317

Clock Distribution Cable



A318

SE to Differential Clock Cable Adapter



A12700

Optical Fiber Series



Cables for CONET Optical Link Networks

APPLICATIONS

- Nuclear and Particle Physics
- Dark Matter and Astroparticle Physics
- Fast Neutron spectroscopy
- Fusion Plasma diagnostic, Homeland Security

FORM FACTOR



VME64 VME64X NIM DESKTOP

FEATURES

USB Digital I/O Optical Link

Well suited for fast signals



751 Digitizer Family

8-4/4-2 Ch. 10-bit 1/2 GS/s Digitizer

Overview

The 751 is a family of 10-bit and 1 GS/s Flash ADC Waveform Digitizers with 1 Vpp of input dynamic range (optionally 0.2 Vpp) and DC offset adjustment. It can work also at 2 GS/s when operating in Dual Edge Sampling (DES) mode, interleaving pairs of input channels.

It is available in three form factors: VME (8 input channels), NIM and Desktop (4 input channels). When in DES mode, half the number of channels is available.

Considering the sampling frequency and the bit number, These digitizers are well suited for fast signals as the ones coming from fast organic, inorganic and liquid scintillators coupled to PMTs or Silicon Photomultipliers, Diamond detectors and others.

The acquisition capabilities take advantage of the multi-buffer organization of the channel memory (divisible into a maximum of 1024 buffers). The data stream is continuously written in a circular memory buffer. When the trigger occurs, the digitizer writes further samples for the post trigger and freezes the buffer that can be read by one of the provided readout links. The acquisition can continue without any dead time in a new buffer. Two memory sizes are available according to the different versions of the x751 model: 1.8-3.6 MS/ch or 14.4-28.8 MS/ch.

The on-board FPGAs can run default firmware for waveform recording as well as Digital Pulse Processing algorithms (DPP) making the digitizer an enhanced system for Physics applications. In addition to the existing firmware selection, CAEN is willing to collaborate with customers for developing custom solutions.

A common acquisition trigger signal can be provided externally, via front panel digital input connector, or via software. Alternatively, each



channel can generate a trigger request when the input pulse goes under/over a programmable threshold; the trigger requests can be used either locally by the channel (independent triggering with DPP firmware) or processed by the board to generate a common trigger causing all the enable channels to acquire an event simultaneously (default firmware). The trigger from one board can be provided out on a front panel digital output connector.

751 family supports multi-board synchronization making a multi-board system where all ADCs result to be synchronized to a common clock source, and ensuring Trigger Time Tag alignment. Once synchronized, all data will be aligned and coherent across multiple x751 boards.

Features

- 10-bit @ 1-2 GS/s
- Analog inputs on MCX coax. connectors (single ended)
- VME64/VME64X (8-4 ch.), NIM (4-2 ch.) and Desktop (4-2 ch.) modules
- 0.2 or 1 Vpp input dynamic range with programmable DC offset adj.
- Algorithms for Digital Pulse Processing (DPP)
- VME, USB and Optical Link communication interfaces
- Multi-board synchronization features
- Daisy chain capability
- Demo software tools, Control Software for default and DPP firmware, C and LabVIEW libraries

Firmware	Software	Features
		Digital Waveform Recording
		Charge Integration Pulse Shape Discrimination Constant Fraction Discriminator
		Digital Waveform Recording with Enhanced Zero Suppression

Technical Specifications

GENERAL

Form Factor
1-unit wide, 6U VME64/VME64X
1-unit wide NIM
154x50x164 mm³ (WxHxD) Desktop

ANALOG INPUT

Channels
8-4 channels, single ended (VME)
4-2 channels, single ended (NIM, Desktop)

Impedance
50 Ω (1 and 0.2 Vpp)

Connector
MCX

Full Scale Range (FSR)
1 Vpp (0.2 Vpp by ordering code)

Bandwidth
500 MHz

Offset
Programmable DAC for DC offset adjustment. Range: ± 0.5 V @ 1 Vpp, ± 0.1 V @ 0.2 Vpp

DIGITAL CONVERSION

Resolution
10 bits

Sampling rate
250 to 1000 MS/s simultaneously on each channel (double in DES mode)

ADC CLOCK GENERATION

Clock source: internal/external
On-Board PLL provides ADC sampling clock generation from an internal (50 MHz loc. oscillator) or external (front panel CLK-IN connector) reference

MEMORY

1.835 MS/ch (3.6 MS/ch in DES mode) or 14.4 MS/ch (28.8 MS/ch in DES mode) Multi Event Buffer with independent read and write access divisible into $1 \div 1024$ buffers
Programmable event size and pre-post trigger

TRIGGER

Trigger source
Self-trigger: channel over/under threshold for either Common or Individual (DPP firmware only) trigger generation
External-trigger: Common by TRG-IN or Individual by LVDS connectors (DPP firmware only)
Software-trigger: Common by software command

Trigger propagation
TRG-OUT (VME) / GPO (NIM and Desktop) digital output

Trigger Time Stamp
Default Firmware, DPP-ZLE: 31-bit counter, 16 ns resolution, 17 s range(*); 48-bit extension by firmware

DPP-PSD Firmware: 32-bit counter, 1 ns resolution, 4 s range, expandable to 64-bit; 10-bit and 1 ps fine time stamp by digital CFD; 64-bit extension by software

SYNCHRONIZATION

Clock propagation
Daisy chain (VME only) through CLK-IN/CLK-OUT connectors
One-to-many clock distribution from an external clock source
Clock Cable delay compensation

Acquisition Synchronization
Sync Start/Stop through digital I/O (S-IN, TRG-IN or GPI input, TRG-OUT or GPO output)
External Trigger Time Stamp reset

LVDS I/O (VME only)

16 general purpose LVDS I/Os controlled by FPGA
Busy, Data Ready, Memory full, Individual Trig-Out and other functions can be programmed An Input Pattern from the LVDS I/Os can be associated to each trigger as an event marker

ANALOG MONITOR (VME only)

12-bit/100 MHz DAC FPGA controlled output with four operating modes: Trigger Majority / Test Pulses / Memory Occupancy / Voltage Level

COMMUNICATION INTERFACE

Optical Link
CAEN CONET proprietary protocol, up to 80 MB/s transfer rate
Daisy chainable: it is possible to connect up to 8/32 ADC modules to a single Optical Link Controller (Mod. A2818/A3818)

USB (NIM and Desktop direct, VME via V1718 bridge)

USB 2.0 compliant
Transfer rate up to 30 MB/s

VME
VME 64X compliant

Data transfer mode: BLT32, MBLT64 (70 MB/s using CAEN Bridge), CBLT32/64, 2eVME, 2eSST (up to 200 MB/s)

POWER CONSUMPTIONS

Desktop: 1.8 A @ 12 V (Typ.)
NIM: 3.9 A @ +6 V, 120 mA @ -6 V
VME: 6.5 A @ +5 V, 200 mA @ +12 V, 300 mA @ -12 V

(*) Trigger Logic and Trigger Time Stamp counter operate at 125 MHz (i.e. 8 ns or 1/2 ADC clock cycles), while the counter value is read at a frequency of 62.5 MHz (i.e. 16 ns).

Ordering Options

Code	Description	Form Factor
WDT5751XAAAA	DT5751 - 2/4 Ch. 10 bit 2/1 GS/s Digitizer: 3.6/1.8MS/ch, EP3C16, SE	Desktop
WN6751XAAAA	N6751 - 2/4 Ch. 10 bit 2/1 GS/s Digitizer: 3.6/1.8MS/ch, EP3C16, SE	NIM
WN6751CXAAAA	N6751C - 2/4 Ch. 10 bit 2/1 GS/s Digitizer: 28.8/14.4MS/ch, EP3C16, SE	NIM
WV1751XAAAA	V1751 - 4/8 Ch. 10 bit 2/1 GS/s Digitizer: 3.6/1.8MS/ch, EP3C16, SE	6U-VME64
WV1751CXAAAA	V1751C - 4/8 Ch. 10 bit 2/1 GS/s Digitizer: 28.8/14.4MS/ch, EP3C16, SE	6U-VME64
WVX1751XAAAA	VX1751 - 4/8 Ch. 10 bit 2/1 GS/s Digitizer: 3.6/1.8MS/ch, EP3C16, SE	6U-VME64X
WVX1751CXAAA	VX1751C - 4/8 Ch. 10 bit 2/1 GS/s Digitizer: 28.8/14.4MS/ch, EP3C16, SE	6U-VME64X
WPERS0175102	751 Customization - 200 mVpp Input Range, SE	ALL
WFDPPNGAA51	DPP-PSD - Digital Pulse Processing for Pulse Shape Discrimination (x751)	ALL
WFDPPZLAA51	DPP-ZLE - Digital Pulse Processing Zero Length Encoding for (x751)	ALL

Accessories

A2818
PCI CONET Controller



A3818
PCI Express CONET2 Controller



A654
MCX to LEMO Cable Adapter



A659
MCX to BNC Cable Adapter



A317
Clock Distribution Cable



A318
SE to Differential Clock Cable Adapter



A12700
Optical Fiber Series



Cables for CONET Optical Link Networks

APPLICATIONS

- High resolution Time of Flight
- Optical Physics
- Fast Neutron spectroscopy

FORM FACTOR

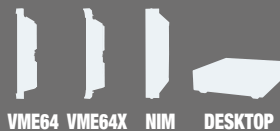

FEATURES

USB Digital I/O Optical Link

The fastest Flash ADC of the series

761 Digitizer Family

2/1 Ch. 10-bit 4 GS/s Digitizer

Overview

The 761 is a family of 10-bit and 4 GS/s Flash ADC Waveform Digitizers with 1 Vpp of input dynamic range and DC offset adjustment.

It is available in three form factors: VME (2 input channels), NIM (1 input channel) and Desktop (1 input channel).

Considering the sampling frequency and the bit number, these digitizers are well suited for very fast signals as the ones coming from PMTs or Silicon Photomultipliers, Diamond detectors and others.

The acquisition capabilities take advantage of the multi-buffer organization of the channel memory (divisible into a maximum of 1024 buffers). The data stream is continuously written in a circular memory buffer. When the trigger occurs, the digitizer writes further samples for the post trigger and freezes the buffer that can be read by one of the provided readout links. The acquisition can continue without any dead time in a new buffer. Two memory sizes are available according to the different versions of the x761 model: 7.2 MS/ch or 57.6 MS/ch.

The on-board FPGAs allow for real-time data processing. In addition to the existing default firmware for waveform recording, CAEN is willing to collaborate with customers for developing custom solutions.

A common acquisition trigger signal can be provided externally, via front panel digital input connector, or via software. Alternatively, each channel can generate a trigger request when the input pulse goes under/over a programmable threshold; the trigger requests are processed by the board to generate a common trigger causing all the enabled channels to acquire an event simultaneously. The trigger from one board can be provided out on a front panel digital output connector.

761 family supports multi-board synchronization making a multi-board system where all ADCs result to be synchronized to a common clock source, and ensuring Trigger Time Tag alignment. Once synchronized, all data will be aligned and coherent across multiple x761 boards.



Features

- 10-bit @ 4 GS/s
- Analog inputs on MCX coax. connectors (single ended)
- VME64/VME64X (2 ch.), NIM (1 ch.) and Desktop (1 ch.) modules
- 1 Vpp input dynamic range with programmable DC offset adj.
- VME, USB and Optical Link communication interfaces
- Multi-board synchronization features
- Daisy chain capability
- Demo software tools, C and LabVIEW libraries

Firmware	Software	Features
		Digital Waveform Recording

Technical Specifications

GENERAL

Form Factor

1-unit wide, 6U VME64/VME64X
1-unit wide NIM
154x50x164 mm³ (WxHxD) Desktop

ANALOG INPUT

Channels

2 channels, single ended (VME)
1 channel, single ended (NIM, Desktop)

Impedance

50 Ω

Connector

MCX

Full Scale Range (FSR)

1 V_{pp}

Bandwidth

1 GHz

Offset

Programmable DAC for DC offset adjustment. Range: ± 0.5 V

DIGITAL CONVERSION

Resolution

10 bits

Sampling rate

4 GS/s simultaneously on each channel

ADC CLOCK GENERATION

Clock source: internal/external

On-Board PLL provides ADC sampling clock generation from an internal (50 MHz loc. oscillator) or external (front panel CLK-IN connector) reference

MEMORY

7.2 MS/ch or 57.6 MS/ch Multi Event Buffer with independent read and write access divisible into 1 \div 1024 buffers

Programmable event size and pre-post trigger

TRIGGER

Trigger source

Self-trigger: channel over/under threshold for Common trigger generation

External-trigger: Common by TRG-IN connector

Software-trigger: Common by software command

Trigger propagation

TRG-OUT (VME) / GPO (NIM and Desktop) digital output

Trigger Time Stamp

31-bit counter, 16 ns resolution, 17 s range(*); 48-bit extension by firmware

SYNCHRONIZATION

Clock propagation

Daisy chain (VME only) through CLK-IN/CLK-OUT connectors

One-to-many clock distribution from an external clock source

Clock Cable delay compensation

Acquisition Synchronization

Sync Start/Stop through digital I/O (S-IN, TRG-IN or GPI input, TRG-OUT or GPO output)

External Trigger Time Stamp reset

LVDS I/O (VME only)

16 general purpose LVDS I/Os controlled by FPGA

Busy, Data Ready, Memory full, Individual Trig-Out and other functions can be programmed An Input Pattern from the LVDS I/Os can be associated to each trigger as an event marker

ANALOG MONITOR (VME only)

12-bit/100 MHz DAC FPGA controlled output with four operating modes: Trigger Majority / Test Pulses / Memory Occupancy / Voltage Level

COMMUNICATION INTEFRACE

Optical Link

CAEN CONET proprietary protocol, up to 80 MB/s transfer rate

Daisy chainable: it is possible to connect up to 8/32 ADC modules to a single Optical Link Controller (Mod. A2818/A3818)

USB (NIM and Desktop direct, VME via V1718 bridge)

USB 2.0 compliant

Transfer rate up to 30 MB/s

VME

VME 64X compliant

Data transfer mode: BLT32, MBLT64 (70 MB/s using CAEN Bridge), CBLT32/64, 2eVME, 2eSST (up to 200 MB/s)

POWER CONSUMPTIONS

Desktop: 1.8 A @ 12 V (Typ.)

NIM: 3.9 A @ +6 V, 120 mA @ -6 V

VME: 6.5 A @ +5 V, 200 mA @ +12 V, 300 mA @ -12 V

(* Trigger Logic and Trigger Time Stamp counter operate at 125 MHz (i.e. 8 ns or 32 ADC clock cycles), while the counter value is read at a frequency of 62.5 MHz (i.e. 16 ns).

Ordering Options

Code	Description	Form Factor
WDT5761XAAAA	DT5761 - 1 Ch.10 bit 4 GS/s Digitizer: 7.2MS/ch, EP3C16, SE	Desktop
WN6761XAAAA	N6761 - 1 Ch. 10 bit 4 GS/s Digitizer: 7.2MS/ch, EP3C16, SE	NIM
WV1761XAAAA	V1761 - 2 Ch.10 bit 4 GS/s Digitizer: 7.2MS/ch, EP3C16, SE	6U-VME64
WV1761CXAAAA	V1761C - 2 Ch. 10 bit 4 GS/s Digitizer: 57.6MS/ch, EP3C16, SE	6U-VME64
WVX1761XAAAA	VX1761 - 2 Ch.10 bit 4 GS/s Digitizer: 7.2MS/ch, EP3C16, SE	6U-VME64X
WVX1761CXAAA	VX1761C - 2 Ch. 10 bit 4 GS/s Digitizer: 57.6MS/ch, EP3C16, SE	6U-VME64X

Accessories

A2818

PCI CONET Controller



A3818

PCI Express CONET2 Controller



A654

MCX to LEMO Cable Adapter



A659

MCX to BNC Cable Adapter



A317

Clock Distribution Cable



A318

SE to Differential Clock Cable Adapter



AI2700

Optical Fiber Series



Cables for CONET Optical Link Networks

APPLICATIONS

- Nuclear and Particle Physics
- Astroparticle Physics
- Time of Flight
- Medical Imaging (PET)

FORM FACTOR



FEATURES

- USB
- Digital I/O
- Optical Link



Based on the DRS4 a Switched Capacitor Array

Very fast Switched Capacitor Digitizer with high channel density

742 Digitizer Family

32+2/16+1 Ch. 12-bit 5 GS/s Digitizer

Overview

The 742 is a family of 12-bit and 5 GS/s Switched Capacitor Waveform Digitizers with 1 Vpp of input dynamic range and DC offset adjustment, based on the DRS4 chip (Paul Scherrer Institute design).

It is available in three form factors: VME (32+2 input channels), NIM (16+1 input channels) and Desktop (16+1 input channels). Additional analog inputs, each one managing 16 channels (two adjacent 8-channel groups), serve as fast local trigger.

Considering the sampling frequency and the bit number, these digitizers are well suited for very fast signals as the ones coming from fast scintillators coupled to PMTs, Silicon Photomultipliers, APD, Diamond detectors and others.

The analog input signals are continuously sampled inside the DRS4 chip in a circular memory buffer (1024 cells) at the default sampling frequency of 5 GS/s (200 ps of sampling period); 2.5 or 1 GS/s frequencies can also be selected. As a trigger signal arrives, all analog memory buffers are frozen and subsequently digitized with a resolution of 12 bits into a digital memory buffer with independent read and write access. Two memory sizes are available according to the different version of the x742 model: 128 or 1024 events with 1024 samples per event.

During analog to digital conversion process, the x742 cannot handle other triggers, thus generating a Dead Time.

A common acquisition trigger signal can be provided externally via front panel digital input connector or via software, but it can also be generated internally thanks to channel self-trigger capability (only after the A/D conversion, with a trigger latency of 250 ns). The trigger from one board can be provided out on a front panel digital output connector.

Additional analog inputs (TR0 for NIM/Desktop, TR0 and TR1 for VME), can be used as low-latency external trigger signals. These special inputs can be also sampled into the DRS4s analog memory buffers for applications where high resolution timing and time analysis with a common reference signal (like a trigger or system clock) is required.

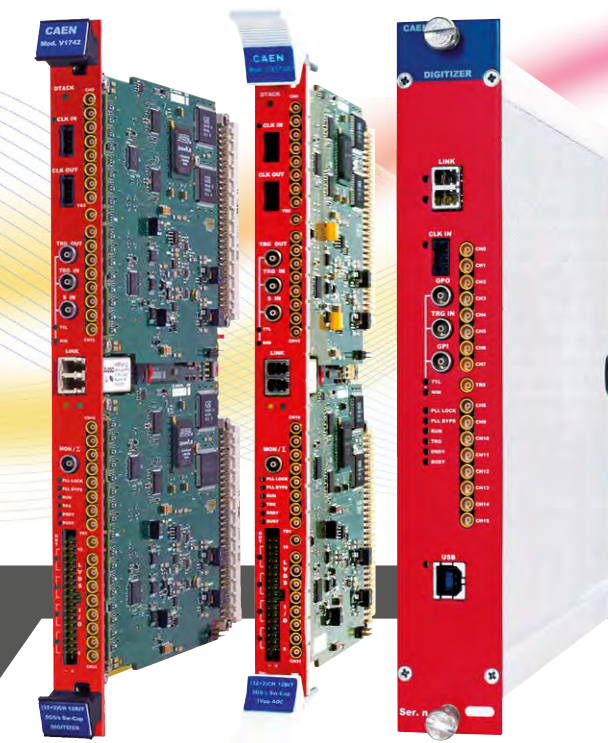

742 family supports multi-board synchronization making a multi-board system where all ADCs result to be synchronized to a common clock source, and ensuring Trigger Time Tag alignment. Once synchronized, all data will be aligned and coherent across multiple x742 boards.

Features

- 12-bit @ 5 GS/s, 1024 samples per event
- 5, 2.5, 1 GS/s software selectable sampling frequencies
- Analog inputs on MCX coaxial connectors
- VME64/VME64X (32+2 ch.), NIM (16+1 ch.) and Desktop (16+1 ch.) modules
- 1 Vpp input dynamic range with programmable DC offset adj.
- VME, USB and Optical Link communication interfaces
- Multi-board synchronization features
- Daisy chain capability
- Demo software tools, C and LabVIEW libraries

x742 is based on the DRS4 a Switched Capacitor Array. This technology relies on a set of capacitors that continuously sample the analog input signals. As soon as the trigger is issued, capacitors are decoupled from the input signals with a time interval from each other that is the sampling period. The trigger therefore freezes the currently stored signal in the sampling capacitance cells. Subsequently the cells are multiplexed into the 12 bit ADC.



Firmware	Software	Features
		Digital Waveform Recording

Technical Specifications

GENERAL

Form Factor

1-unit wide, 6U VME64/VME64X

1-unit wide NIM

154x50x164 mm³ (WxHxD) Desktop

ANALOG INPUT

Channels

32+2 channels, single ended (VME)

16+1 channels, single ended (NIM, Desktop)

Impedance

50 Ω

Connector

MCX

Full Scale Range (FSR)

1 V_{pp}

Bandwidth

500 MHz

Offset

Programmable DAC for DC offset adjustment per channel or 8-channel group. Range: ±1 V

TR0 TR1 Analog Inputs

Special inputs (MCX, 50 Ω) for fast local trigger and high resolution timing reference

NIM/LVTTL signals also supported

DIGITAL CONVERSION

Switched Capacitor array

Domino Ring Sampler chip (DRS4) serving 8+1 channels

1024 storage cells per channel (200 ns minimum recorded time per event)

Resolution

12 bits

Sampling rate

5 (default) - 2.5 - 1 GS/s software selectable, simultaneously on each channel

Dead Time for Event A/D Conversion

110 μs analog inputs only; 181 μs analog inputs + TR0, TR1 inputs

CLOCK GENERATION

Synchronization clock source: internal/external

On-Board PLL provides generation of main board clocks from an internal (50 MHz loc. oscillator) or external (front panel CLK-IN connector) reference

MEMORY

128 events/ch or 1024 events/ch (1024 samples per event) Multi-Event Buffer

TRIGGER

Trigger source

Self-trigger: channel over/under threshold by digital discriminator on all channels (after A/D conversion; involves a 250-ns latency)

Fast local trigger: by analog discriminator on TR0 and TR1 special inputs (each TRn signal triggers 16 channels)

External-trigger: Common by TRG-IN connector

Software-trigger: Common by software command

Trigger propagation

TRG-OUT (VME) / GPO (NIM and Desktop) digital output

Trigger Time Stamp

30-bit counter, 8.5 ns resolution, 9 s range

LVDS I/O (VME only)

16 general purpose LVDS I/Os controlled by FPGA

Busy, Data Ready, Memory full, Individual Trig-Out and other functions can be programmed An Input Pattern from the LVDS I/Os can be associated to each trigger as an event marker

SYNCHRONIZATION

Clock propagation

Daisy chain (VME only) through CLK-IN/CLK-OUT connectors

One-to-many clock distribution from an external clock source

Clock Cable delay compensation

Acquisition Synchronization

Sync Start/Stop through digital I/O (S-IN, TRG-IN or GPI input, TRG-OUT or GPO output)

External Trigger Time Stamp reset

COMMUNICATION INTERFACE

Optical Link

CAEN CONET proprietary protocol, up to 80 MB/s transfer rate

Daisy chainable: it is possible to connect up to 8/32 ADC modules to a single Optical Link Controller (Mod. A2818/A3818)

USB (NIM & Desktop direct, VME via V1718 bridge)

USB 2.0 compliant

Transfer rate up to 30 MB/s

VME

VME 64X compliant

Data transfer mode: BLT32, MBLT64 (70 MB/s using CAEN Bridge), CBLT32/64, 2eVME, 2eSST (up to 200 MB/s)

POWER CONSUMPTIONS

Desktop: 1.7 A @ 12 V (Typ.)

NIM: 3.9 A @ +6 V, 90 mA @ -6 V

VME: 5.5 A @ +5 V, 200 mA @ +12 V, 300 mA @ -12 V

Ordering Options

Code	Description	Form Factor
WDT5742XAAAA	DT5742 - 16+1 Ch. 12 bit 5 GS/s Switched-Capacitor Digitizer: 128 events/ch (1kS/event), EP3C16, SE	Desktop
WDT5742BXAAA	DT5742B - 16+1 Ch. 12 bit 5 GS/s Switched-Capacitor Digitizer: 1024 events/ch (1kS/event), EP3C16, SE	Desktop
WN6742XAAAAA	N6742 - 16+1 Ch. 12 bit 5 GS/s Switched-Capacitor Digitizer: 128 events/ch (1kS/event), EP3C16, SE	NIM
WN6742BXAAAA	N6742B - 16+1 Ch. 12 bit 5 GS/s Switched-Capacitor Digitizer: 1024 events/ch (1kS/event), EP3C16, SE	NIM
WV1742XAAAAA	V1742 - 32+2 Ch. 12 bit 5 GS/s Switched-Capacitor Digitizer: 128 events/ch (1kS/event), EP3C16, SE	6U-VME64
WV1742BXAAAA	V1742B - 32+2 Ch. 12 bit 5 GS/s Switched-Capacitor Digitizer: 1024 events/ch (1kS/event), EP3C16, SE	6U-VME64
WVX1742XAAAA	VX1742 - 32+2 Ch. 12 bit 5 GS/s Switched-Capacitor Digitizer: 128 events/ch (1kS/event), EP3C16, SE	6U-VME64X
WVX1742BXAAA	VX1742B - 32+2 Ch. 12 bit 5 GS/s Switched-Capacitor Digitizer: 1024 events/ch (1kS/event), EP3C16, SE	6U-VME64X

Accessories

A2818

PCI CONET Controller



A3818

PCI Express CONET2 Controller



A654

MCX to LEMO Cable Adapter



A659

MCX to BNC Cable Adapter



A317

Clock Distribution Cable



A318

SE to Differential Clock Cable Adapter



AI2700

Optical Fiber Series



Cables for CONET Optical Link Networks

APPLICATIONS

- Nuclear and Particle Physics
- Astroparticle Physics
- Time of Flight
- Medical Imaging (PET)

FORM FACTOR



VME64 VME64X NIM DESKTOP

FEATURES

USB Digital I/O Optical Link



Based on the
SAMLONG,
a Switched
Capacitor Array

Fast Switched Capacitor Digitizer with self trigger and charge integration

743 Digitizer Family

16/8 Ch. 12-bit 3.2 GS/s Digitizer



Overview

The 743 is a family of 12-bit and 3.2 GS/s Switched Capacitor Waveform Digitizers with 2.5 Vpp of input dynamic range and DC offset adjustment, issued from the collaboration with CEA/IRFU & CNRS/IN2P3/LAL and based on the SAMLONG chip.

It is available in three form factors: VME (16 input channels), NIM (8 input channels) and Desktop (8 input channels).

Considering the sampling frequency and the number of bits, these digitizers are well suited for very fast signals as the ones coming from fast scintillators coupled to PMTs, Silicon Photomultipliers, APD, Diamond detectors and others.

The analog input signals are continuously sampled inside the SAMLONG chip in a circular memory buffer (1024 cells) at the default sampling frequency of 3.2 GS/s (312.5 ps of sampling period); 1.6, 0.8 or 0.4 GS/s frequencies can also be selected. As a trigger signal arrives, all analog memory buffers are frozen and subsequently digitized with a resolution of 12 bits into a digital memory buffer with independent read and write access. Up to 7 full events per channel can be stored where 1 event is made of 1024 samples.

During analog to digital conversion process, the x743 digitizer cannot handle other triggers, thus generating a Dead Time.

A common acquisition trigger signal can be provided externally via front panel digital input connector or via software. Alternatively each channel is equipped with a discriminator, with programmable threshold, generating trigger requests. The requests from the enabled channels are processed by the board to generate a common trigger causing the event to be stored simultaneously (for all enabled channels). These requests are also used by counters to continuously calculate the individual channel hit rates, also during the Dead Time. The trigger from one board can be provided on a front panel digital output connector.



Each channel is equipped with an individual fixed amplitude pulser for test and reflectometry applications. An on-board charge mode option can be enabled for charge calculation and fast histogramming.

743 family supports multi-board synchronization making a multi-board system where all ADCs result to be synchronized to a common clock source, and ensuring Trigger Time Tag alignment. Once synchronized, all data will be aligned and coherent across multiple x743 boards.

Features

- 12-bit @ 3.2 GS/s, 1024 samples per event
- 3.2, 1.6, 0.8, 0.4 GS/s software selectable sampling frequencies
- Analog inputs on MCX coaxial connectors
- VME64/VME64X (16 ch.), NIM (8 ch.) and Desktop (8 ch.) modules
- 2.5 Vpp input dynamic range with programmable DC offset adjustment
- One discriminator per channel with programmable threshold
- Adjustable post-trigger delay (up to 1.25 μ s @ 3.2 GS/s)
- One embedded pulser per channel for test and reflectometry applications
- On-board charge calculation for fast histogramming
- VME, USB and Optical Link communication interfaces
- Multi-board synchronization features
- Daisy chain capability
- Oscilloscope software tool, C and LabVIEW libraries

Firmware	Software	Features
		Digital Waveform Recorder Charge Integration Constant Fraction Discrimination

x743 is based on the SAMLONG, a Switched Capacitor Array. This technology relies on a set of capacitors that continuously sample the analog input signals at a fixed time interval which corresponds to the sampling period. When the trigger is issued, capacitors are decoupled from the input signals after a programmable delay. The trigger therefore freezes the currently stored signal in the sampling capacitance cells. Subsequently the cells are multiplexed into the 12-bit ADC.



x743 features an embedded Charge Mode, where the pulse integration window is defined by the user. This feature allows to perform on-line processing on detector signal directly digitized.

Technical Specifications

GENERAL

Form Factor

1-unit wide, 6U VME64/VME64X

1-unit wide NIM

154x50x164 mm³ (WxHxD) Desktop

ANALOG INPUT

Channels

16 channels, single ended (VME)

8 channels, single ended (NIM, Desktop)

Impedance

50 Ω

Connector

MCX

Full Scale Range (FSR)

2.5 Vpp

Bandwidth

500 MHz

Offset

Programmable DAC for DC offset adjustment.

Range: ±1.25 V

DIGITAL CONVERSION

Switched Capacitor array

SAMLONG fast analog memory chip serving 2 channels

1024 storage cells per channel (320 ns minimum recorded time per event)

Resolution

12 bits

Sampling rate

3.2 (default) - 1.6 - 0.8 - 0.4 GS/s software selectable, simultaneously on each channel

Dead Time for Event A/D conversion

125 μs (max. @1024 samples)

CLOCK GENERATION

Synchronization clock source: internal/external

On-Board PLL provides generation of main board clocks from an internal (50 MHz loc. oscillator) or external (front panel CLK-IN connector) reference

MEMORY

7 events/ch (1024 samples per event) Multi-Event Buffer

TRIGGER

Trigger source

Self-trigger: channel over/under threshold (based on individual discriminator with DAC adjusted threshold) for Common trigger generation

External-trigger: Common by TRG-IN connector

Software-trigger: Common by software command

Trigger propagation

TRG-OUT (VME) / GPO (NIM and Desktop) digital output

Trigger Time Stamp

40-bit counter, 5 ns resolution, 90 minutes range (@ 3.2 GS/s)

LVDS I/O (VME only)

16 general purpose LVDS I/Os controlled by FPGA

Busy, Data Ready, Memory full, Individual Trig-Out and other functions can be programmed An Input Pattern from the LVDS I/Os can be associated to each trigger as an event marker

SYNCHRONIZATION

Clock propagation

Daisy chain (VME only) through CLK-IN/CLK-OUT connectors

One-to-many clock distribution from an external clock source Clock Cable delay compensation

Acquisition Synchronization

Sync Start/Stop through digital I/O (S-IN, TRG-IN or GPI input, TRG-OUT or GPO output)

External Trigger Time Stamp reset

COMMUNICATION INTEFRACE

Optical Link

CAEN CONET proprietary protocol, up to 80 MB/s transfer rate

Daisy chainable: it is possible to connect up to 8/32 ADC modules to a single Optical Link Controller (Mod. A2818/A3818)

USB (NIM and Desktop direct, VME via V1718 bridge)

USB 2.0 compliant

Transfer rate up to 30 MB/s

VME

VME 64X compliant

Data transfer mode: BLT32, MBLT64 (70 MB/s using CAEN Bridge), CBLT32/64, 2eVME, 2eSST (up to 200 MB/s)

POWER CONSUMPTIONS

Desktop: 1.5 A @ 12 V (Typ.)

NIM: 2.9 A @ +6 V, 500 mA @ -6 V

VME: 4 A @ +5 V, 625 mA @ +12 V, -12 V not used

Ordering Options

Code	Description	Form Factor
WDT5743XAAAA	DT5743 - 8 Ch. 12 bit 3.2GS/s Switched-Capacitor Digitizer: 7 events/ch (1kS/event), EP3C16, SE	Desktop
WN6743XAAAAA	N6743 - 8 Ch. 12 bit 3.2GS/s Switched-Capacitor Digitizer: 7 events/ch (1kS/event), EP3C16, SE	NIM
WV1743XAAAAA	V1743 - 16 Ch. 12 bit 3.2GS/s Switched-Capacitor Digitizer: 7 events/ch (1kS/event), EP3C16, SE	6U-VME64
WVX1743XAAAA	VX1743 - 16 Ch. 12 bit 3.2GS/s Switched-Capacitor Digitizer: 7 events/ch (1kS/event), EP3C16, SE	6U-VME64X

Accessories

A2818

PCI CONET Controller



A3818

PCI Express CONET2 Controller



A654

MCX to LEMO Cable Adapter



A659

MCX to BNC Cable Adapter



A317

Clock Distribution Cable



A318

SE to Differential Clock Cable Adapter



A12700

Optical Fiber Series



Cables for CONET Optical Link Networks



Acquisition Modes

Firmware and Software Selection

Thanks to their flexibility, CAEN Digitizers can be operated as pure waveform recorders or can run special algorithms to process the digitized pulses and extract a set of significant information like energy, pulse shape and precise timing. Each acquisition mode makes use of a specific firmware and software to tailor the digitizer capabilities to the user's needs.



Hardware



Firmware

Waveform Recording Firmware



- Time windowed waveform recording
- Dead-timeless acquisition
- Multi-buffer memories
- Multi-board synchronization
- High bandwidth data readout

Digital Pulse Processing (DPP) Firmware

Dynamic Acquisition Window	Zero Length Encoding	Pulse Height Analysis
Charge to Digital Conversion	Gated Charge Integration and Pulse Shape Discrimination	



Software

Waveform Recording Software

SCOPE CAEN	Signal Inspection and Waveform Recording Software
WAVE DUMP CAEN	Open Source Acquisition Software for Developers
CAEN WAVECATCHER	Advanced Software Tool for 743 Digitizers



DPP Software

COMPASS CAEN	Multiparametric DAQ Software for Physics Applications	MC² CAEN	User Friendly Software for DPP-PHA Management
PSD CAEN	Graphical Interface for DPP-PSD Management	QDC CAEN	Demo Software for DPP-QDC Management
ZLE+ CAEN	Demo Software for DPP-ZLEplus Management	DAW CAEN	Demo Software for DPP-DAW Management

Digitizer Family



- 720
- 724
- 725
- 730
- 740
- 751

Supported Firmware

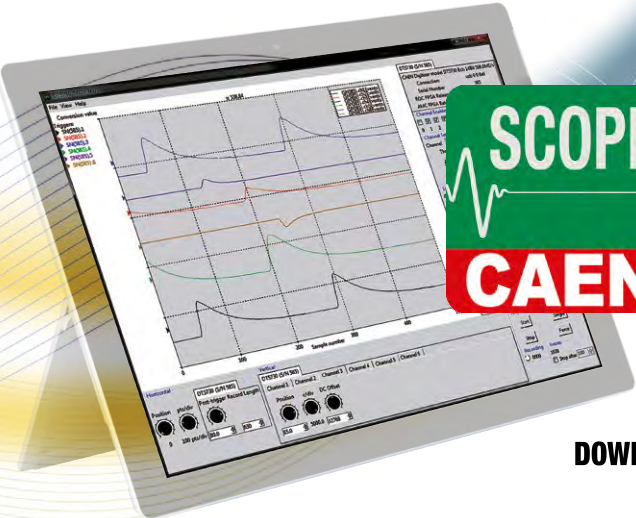
FREE DOWNLOAD  



SCOPE
CAEN

FREE DOWNLOAD   

Waveform Recording

CAENScope
Signal Inspection and Waveform Recording Software

Overview



CAENScope is a user friendly software interface to specifically control CAEN digitizer running “Default Firmware” (waveform recording). CAEN Scope allows the user to easily connect to a single board, retrieve the hardware information, manage the acquisition and data recording. In a single program frame, different parameters can be set for the channels, the trigger (e.g. external, software or channel trigger) and the traces (e.g. vertical and horizontal digital settings, and hardware settings as well). Up to 12 traces can be simultaneously plotted. A wave recording session can be programmed even by number of events and then saved to files in a Binary (SQLite db) or Text (XML) format. It is possible to load a recorded session and have it on the display with the recording date and the trace from each enabled channel, scrolling it event by event. The user can also export and import the software settings at his convenience.

Features

- User friendly single frame GUI with intuitive controls
- Compatible with CAEN Waveform Digitizers
- Extended plot and record capability up to 12 simultaneous traces
- High configuration flexibility:
 - individual channel enable/disable
 - individual channel trigger threshold and DC offset adjustment
 - common trigger among channels
 - external trigger enable/disable
 - auto trigger
- Multi format (ASCII, binary) data saving
- Import/Export of recorded waveform and software settings
- Compliant with Windows and Linux platforms

Applications

- Signal inspection and waveform recording
- Research and development of prototypes
- Data collection for offline statistical analysis
- Beam monitoring
- Sensors readout and detectors’ performances
- Lidar

Features	Firmware	Software	Digitizer Family	Max Sampling Rate (MS/s)	Resolution (bits)	Channels
Digital Waveform Recorder			720	250	12	8/4/2
			724	100	14	8/4/2
			725	250	14	16/8
			730	500	14	16/8
			740	62.5	12	64/32
			751	1000-2000	10	8-4/4-2



 **FREE
DOWNLOAD**

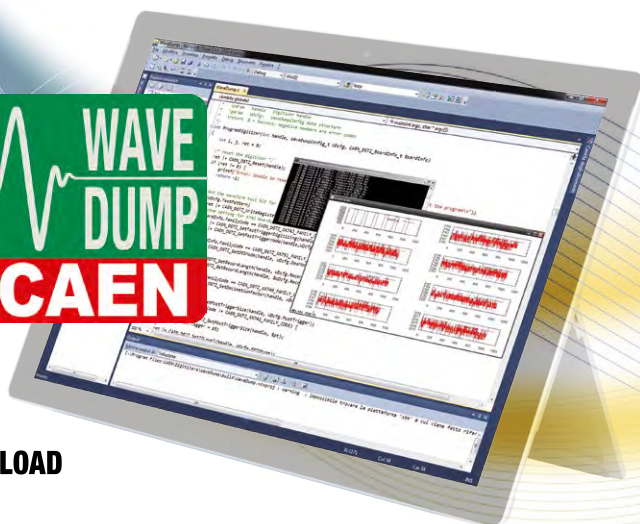

Digitizer Family

720 724
725 730
740 742
751 761



Supported Firmware



 **FREE
DOWNLOAD**

WaveDump Open Source Acquisition Software for Developers

Waveform Recording

Features

- Basic console for waveforms acquisition
- Compliant with CAEN digitizers
- Multichannel waveform plot
- Advanced mode configuration:
 - common board settings
 - individual settings for threshold and DC offset adjustment
 - 725-730-751 ADC calibration
- Advanced mathematical functions: amplitude spectra and FFT
- Configuration of 742 boards and DRS4 chip corrections
- Multi format (ASCII, binary) data saving
- Source files and Visual Studio project open source for developers



Applications

- Signal inspection and waveform recording
- Research and development of prototypes
- Data collection for offline statistical analysis
- Beam monitoring
- Sensors readout and detectors' performances
- Lidar

Overview

WaveDump is a basic console application supporting digitizers running default firmware. WaveDump allows the user to program a single board (according to a text configuration file containing a list of parameters and instructions), to start/stop the acquisition. It is then possible to read the data, display the readout and trigger rate. Moreover, it is also possible to apply some post-processing (e.g. FFT and amplitude histogram), save data into a file and also plot the waveforms using Gnuplot third-party graphical utility.

WaveDump is a very helpful example of C code demonstrating the use of libraries and methods for an efficient readout and data analysis. Expert users can start with this demo to write their own acquisition software to exploit the full potentialities of the digitizers. Source files and the VS project are available for free download.

Features	Firmware	Software	Digitizer Family	Max Sampling Rate (MS/s)	Resolution (bits)	Channels
Digital Waveform Recorder			720	250	12	8/4/2
			724	100	14	8/4/2
			725	250	14	16/8
			730	500	14	16/8
			740	62.5	12	64/32
			742	5000	12	32+2/16+1
			751	1000-2000	10	8-4/4-2
			761	4000	10	2/1

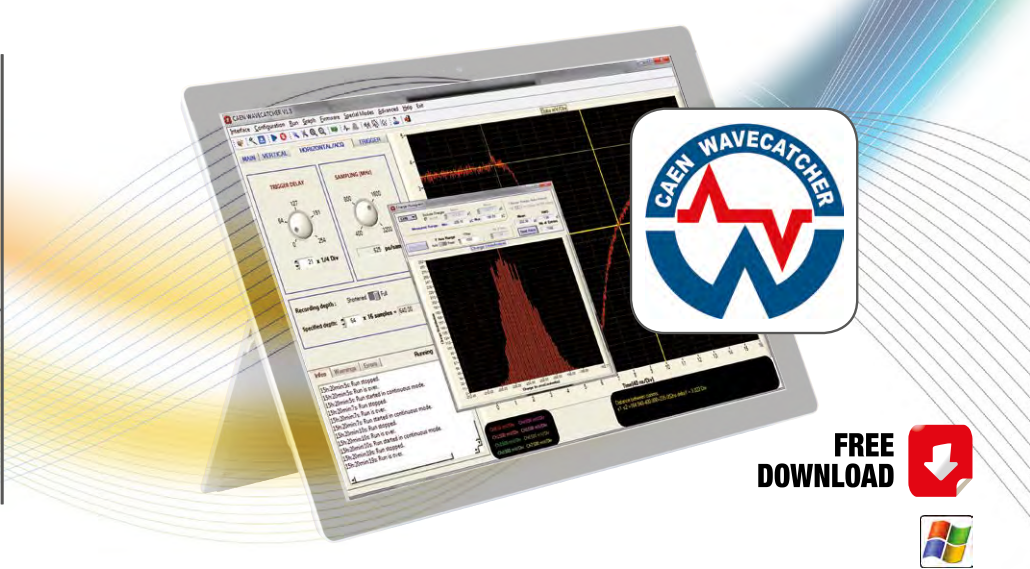
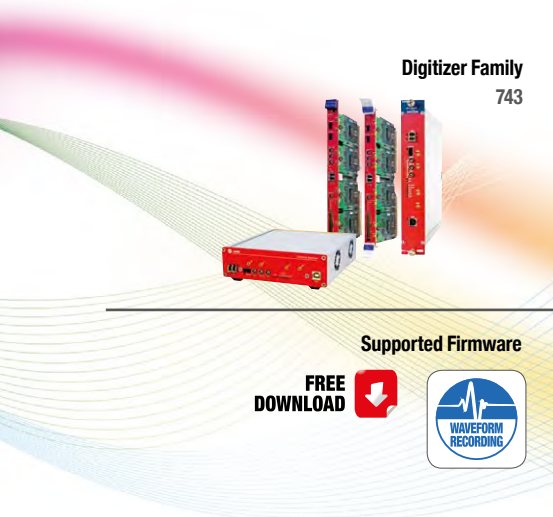

Waveform Recording

WaveCatcher Advanced Software Tool for 743 Digitizers

Overview

The WaveCatcher software and the default firmware for 743 family is a complete oscilloscope-like tool made by CNRS/IN2P3/LAL, which is able to control a single board belonging to the CAEN 743 Digitizer series.

A graphical user friendly interface is available to take benefit of all the functions of the hardware: sampling frequency, different trigger modes, waveforms and charge data acquisition, channel pulses, etc.

The system also features different tools for on-line measurements and histograms plotting: graphical cursors, noise level, raw hit rates, charge amplitude and time measurements, time distance histograms between channels (fixed threshold and digital CFD methods), charge histograms, FFT, etc.



All acquired data and computed measurements can be saved to files for further off-line analysis.

Features

- Software by CNRS/IN2P3/LAL to control x743 digitizers
- Single-board communication and data acquisition management
- Friendly Graphical User Interface for board configuration and on-line measurements setting
- Waveforms, charge and time histograms advanced plotting
- Advanced menu for Rate, Noise and Time measurements
- Saving and recalling options for configuration parameters and data
- Data saving (waveforms and/or measurements) in ASCII and Binary file formats for storage or off-line analysis
- Compliant with Windows OS and Linux (Coming Soon)

Applications

- Signal inspection and waveform recording
- Research and development
- Precise Timing for Time of Flight measurements
- Lidar

Features	Firmware	Software	Digitizer Family	Max Sampling Rate (MS/s)	Resolution (bits)	Channels
Digital Waveform Recorder Charge Integration Constant Fraction Discrimination			743	3200	12	16/8



**FREE
DOWNLOAD**

Digitizer Family

 720 724
 725 730
 740 751

Supported Firmware

NEW

CoMPASS

Multiparametric DAQ Software for Physics Applications

Digital Pulse Processing

Features

- Software for simultaneous DPP acquisition, including Pulse Height Analysis (PHA)⁽²⁾, Pulse Shape Discrimination (PSD), Charge Integration (CI)⁽¹⁾, and the new digital QDC⁽³⁾
- Multi-board management
- Synchronization of multiple boards even from different families
- Correlation between different channels
- Simultaneous plot of waveform, energy, time, PSD, and TOF spectra
- Energy calibration
- Digital Constant Fraction Discrimination for fine time stamp interpolation (pico second intrinsic resolution)
- Selectable filters on energy, PSD, and Correlation
- Advanced data saving options:
 - Data from board is recorded for the whole acquisition run
 - Time ordered recording of channels acquired data (list mode)
 - Spectra saving
- Data can be retrieved offline to make additional filters and analysis
- ROOT format data saving (Coming Soon)
- Add-on for ROOT integration (Coming Soon)









Overview

CAEN Multi-Parameter Spectroscopy Software (CoMPASS) is the new software from CAEN able to implement a Multi-parametric DAQ for Physics Applications, where the detectors can be connected directly to the digitizers inputs and the software acquires energy, timing, and PSD spectra.

CoMPASS can manage multiple boards, even in synchronized mode, and the event correlation between different channels (in hardware and/or software), apply energy and PSD cuts, calculate and show the statistics (trigger rates, data throughput, etc...), save output data files (raw data, lists, waveforms, spectra) and use the saved files to run off-line with different processing parameters.

Applications

- Nuclear spectroscopy
- Clover detectors
- HPGe, Silicon Drift Detectors
- Neutron physics with scintillation detectors
- Multiple boards synchronization
- Homeland security
- Precise Timing for Time of Flight measurements

Features	Firmware	Software	Digitizer Family	Max Sampling Rate (MS/s)	Resolution (bits)	Channels
Charge Integration Pulse Shape Discrimination			720 ⁽¹⁾	250	12	8/4/2
Charge Integration Pulse Shape Discrimination Constant Fraction Discriminator			725 730 751	250 500 1000-2000	14 14 10	16/8 16/8 8-4/4-2
Pulse Height Analysis			724 ⁽²⁾ 725 730	100 250 500	14 14 14	8/4/2 16/8 16/8
Digital QDC Charge Integration			740 ⁽³⁾	62.5	12	64/32



(1) DPP-CI is no longer supported. To perform Charge Integration please refer to the DPP-PSD
 (3) CoMPASS support of DPP-QDC: Coming Soon

(2) DPP-PHA firmware is no longer supported for 724 models with C4 AMC FPGA option





Digitizer Family
724
725
730

Supported Firmware

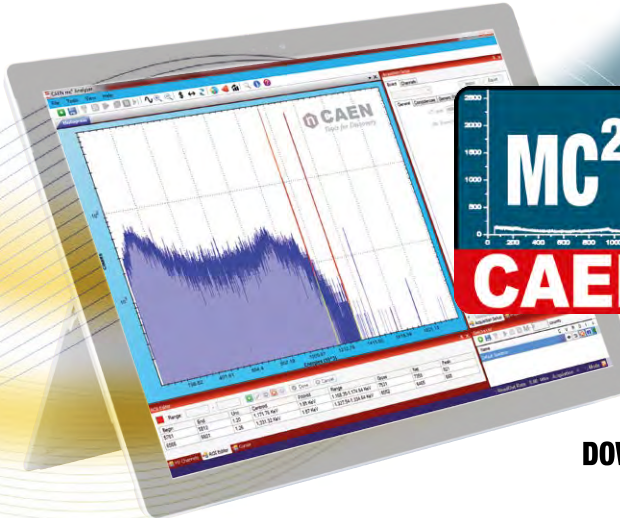
FREE TRIAL VERSION  



MC² CAEN

FREE DOWNLOAD  

Digital Pulse Processing **MC²Analyzer**
User Friendly Software for Digital Pulse Height Analysis

Overview

MC²Analyzer is a software specifically designed to manage CAEN Digital MCA (780/781 family, DT5770, and gamma stream) as well as CAEN digitizers running DPP-PHA (Digital Pulse Processing for the Pulse Height Analysis) firmware, like 724, 725 and 730 families.

The DPP-PHA firmware implements a digital trapezoidal filter on the input pulse, which replaces the traditional analog chain of shaping amplifier and peak sensing ADC. The MCA is therefore directly connected to the charge sensitive preamplifier, with no need of additional devices. The PHA algorithm is able to perform online baseline restoration, ballistic effect corrections, and manage the pile-up for the live time information. PHA and time-stamped list acquisition modes are available.

MC²Analyzer software allows the user to program the relevant DPP-PHA parameters, to manage the HV channels configuration (x780 and gamma stream only), to collect the spectra and perform mathematical analysis, like energy calibration, peak search, background subtraction, peak fitting, etc.

The software is designed with multi-channel and multi-board capabilities: it can handle several boards and manage the data acquisition from each of them at the same time.



Ordering Option



Code	Description
WFDPPPTFAA25	DPP-PHA - Digital Pulse Processing for Pulse Height Analysis (x725)
WFDPPPTFAA30	DPP-PHA - Digital Pulse Processing for Pulse Height Analysis (x730)
WFDPPPTFAAAA	DPP-PHA - Digital Pulse Processing for Pulse Height Analysis (x724)

Features

- Designed for:
 - 724, 725 and 730 Digitizer families
 - 770/780/781 Digital MCA families and gamma stream
- Trapezoidal filter replacing shaping amplifier and peak sensing ADC
- Online baseline restoration and ballistic effect correction
- Online pile-up correction for live-time measurement
- PHA and time-stamped list mode available
- Full setting of all the relevant DPP-PHA parameters and power supplies for DT5780 and gamma stream controlled by the MC²Analyzer software
- Complete simultaneous control of different boards
- Advanced mathematical analysis on collected spectra (peak search, background subtraction, peak fitting, etc.)
- Provides Energy, Time Stamp lists and histograms in ASCII and ANSI N42.42 format (energy spectra for 770 only)

Applications

- Nuclear spectroscopy
- HPGe, silicon drift, silicon strip detectors
- Slow scintillation detectors (i.e. NaI(Tl))
- Anti-compton shielding
- Homeland security
- Environmental survey
- Ion beam analysis
- Nuclear medicine

Features	Firmware	Software	Digitizer Family	Max Sampling Rate (MS/s)	Resolution (bits)	Channels
Pulse Height Analysis			724 ⁽¹⁾	100	14	8/4/2
			725	250	14	16/8
			730	500	14	16/8

(1) DPP-PHA firmware is no longer supported for 724 models with C4 AMC FPGA option

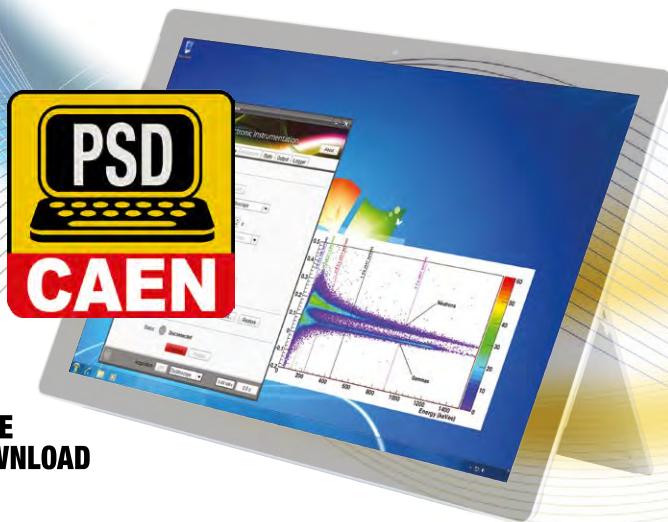

 **FREE
DOWNLOAD**



Digitizer Family

720
725
730
751



Supported Firmware



NEW

DPP-PSD

Digital Charge Integration and Pulse Shape Analysis

Digital Pulse Processing

Features

- Digital solution equivalent to Dual Gate QDC + Discriminator + Gate Generator
- Double charge integration for Pulse Shape Discrimination
- Single gate integration for Energy spectra calculation
- Self Gating (no discriminator) with digital noise filtering
- No delay line is needed to fit the position of the pulse inside the gate
- Programmable width and position of the two gates
- Automatic Baseline subtraction (pedestal)
- Digital Constant Fraction Discrimination for fine time stamp interpolation (pico second intrinsic resolution)
- Dead-timeless acquisition (no conversion time)
- On-line coincidences/anti-coincidence acquisition mode among channels
- Extremely high dynamic range
- Provides also timing information (pulse time stamps)
- Free downloadable firmware trial version
- Demo software to handle digitizer families running DPP-PSD firmware

Applications

- Spectroscopy with scintillation organic/inorganic detectors
- SiPM readout systems
- Neutron physics with liquid scintillation detectors
- Acquisition from phoswich detectors
- Time dependent spectroscopy
- Precise timing for Time of Flight measurements
- Homeland security
- Neutron imaging
- PET
- Tagged neutron for inspection systems





Overview

A digitizer running the DPP-PSD firmware becomes a multichannel data acquisition system for nuclear physics or other applications requiring radiation detectors. The digitizer accepts signals directly from the detector and implements a digital replacement of Dual Gate QDC, Discriminator and Gate Generator. All these functions are performed inside the board FPGA without any use of external cables, nor additional boards or delay lines. The acquisition is therefore performed by a single compact system which replaces the traditional analog boards. It is also possible to operate with multi-board systems: the front panel clock, the trigger and the general purpose LVDS I/Os connectors (VME only) make possible the synchronization of several boards.

The acquisition can be controlled by the DPP-PSD Control Software, a demo program that allows the user to understand the principle of operation of the DPP-PSD algorithm, program the digitizer and control the acquisition and data saving.

Ordering Option

Code	Description
WFWDPPNGAA20	DPP-PSD - Digital Pulse Processing for Pulse Shape Discrimination (x720)
WFWDPPNGAA25	DPP-PSD - Digital Pulse Processing for Pulse Shape Discrimination (x725)
WFWDPPNGAA30	DPP-PSD - Digital Pulse Processing for Pulse Shape Discrimination (x730)
WFWDPPNGAA51	DPP-PSD - Digital Pulse Processing for Pulse Shape Discrimination (x751)

Features	Firmware	Software	Digitizer Family	Max Sampling Rate (MS/s)	Resolution (bits)	Channels
Charge Integration Pulse Shape Discrimination			720	250	12	8/4/2
Charge Integration Pulse Shape Discrimination			725	250	14	16/8
Constant Fraction Discriminator			730	500	14	16/8
			751	1000-2000	10	8-4/4-2

Digitizer Family 740

Supported Firmware

FREE TRIAL VERSION

QDC CAEN

FREE DOWNLOAD

DPP-QDC

NEW

Digital Pulse Processing

Digital Charge to Digital Converter for 740 Digitizers

NEW

Overview

Tired of your old QDC? Try the new digital QDC algorithm for 740 digitizer series. Digital QDC is specifically supported by x740D models mounting EP3C40 Altera FPGA. 740D digitizer series running DPP-QDC firmware become multi-channel data acquisition systems for nuclear physics or other applications requiring radiation detection. The digitizers accept signals directly from the detector and implement a digital replacement of Single Gate QDC, Discriminator and Gate Generator.

The algorithm is able to self-trigger up to 32/64 channels independently, according to the board form factor. Furthermore, the trigger filter of each channel can be programmed independently to allow for a fine tuning of the threshold. The integration gate itself can be programmed independently to get the best resolution from different detector systems.

The new digital QDC is able to self gate on the input pulse with no need of additional delay lines, nor external discriminator.

It is particularly suitable for segmented detector configuration, where multiple channels need to be acquire simultaneously.

CAEN provides open source demo software for a first approach to DPP-QDC algorithm principles and basic control of the digitizer.

Ordering Option

Code	Description
WFWDDPPQDAAA	DPP-QDC- Digital Pulse Processing for Time Stamped Digital QDC (x740)

Features

- Digital solution equivalent to Single Gate QDC + Discriminator + Gate Generator
- **Runs only on x740D models**
- Single gate integration for Energy spectra calculation
- Self-Gating (no discriminator) with digital noise filtering
- No delay line is needed to fit the position of the pulse inside the gate
- Independent 32 (Desktop, NIM) - 64 (VME) channel self-trigger
- Trigger adjustment for single channel
- Programmable gate width and position for single channel
- Automatic Baseline subtraction (pedestal)
- Dead-timeless acquisition (no conversion time)
- Provides also timing information (pulse time stamps)
- Free downloadable firmware trial version
- Demo software to handle 740 digitizer family running DPP-QDC firmware

Applications

- Spectroscopy with scintillation detectors, as NaI(Tl), LaBr₃(Ce), CeBr₃
- Suitable for applications with detector arrays
- Homeland security
- Environmental survey
- Compton camera

Features	Firmware	Software	Digitizer Family	Max Sampling Rate (MS/s)	Resolution (bits)	Channels
Digital QDC Charge Integration			740	62.5	12	64/32



 **FREE
DOWNLOAD**



Digitizer Family

725
730
751



Supported Firmware



DPP-ZLEplus

Advanced Zero Length Encoding

Digital Pulse Processing

Features

- Input signal baseline calculation channel by channel
- Acquisition window generated by an external trigger
- Enhanced Zero Suppression of input signals within the acquisition window
- Upper and Lower Threshold referred to the baseline or to an absolute value
- Programmable Look Back and Look Ahead windows
- Provides also timing information (trigger time stamps)
- Demo software to handle 751 digitizer family running DPP-ZLEplus firmware
- Data plotting using Gnuplot graphical engine
- Source files and Visual Studio project provided for developers

Applications

- Neutrino experiments
- Large number of detectors driven by an external trigger
- Drift chambers, TPC, Cherenkov detectors
- Application requiring an effective data reduction

Overview



The Zero Length Encoding (DPP-ZLEplus) firmware has been developed for the 751 digitizer family (725-730 Coming Soon). It allows the user to transfer the digitized waveforms in compressed mode, performing an enhanced Zero Suppression algorithm on the input signals.

DPP-ZLE continuously calculates the baseline of the input signals and, whenever an external trigger occurs, it searches for the significant input pulses within a user-defined acquisition window. An input pulse is considered significant if it either exceeds an Upper Threshold or falls below a Lower Threshold referred either to the calculated baseline or absolute values.

CAEN provides open source demo software for a first approach to DPP-ZLEplus algorithm principles and basic control of the digitizer.

Ordering Option

Code	Description
WFWDPPZLAA51	DPP-ZLE - Digital Pulse Processing Zero Length Encoding for (x751)

Features	Firmware	Software	Digitizer Family	Max Sampling Rate (MS/s)	Resolution (bits)	Channels
Digital Waveform Recorder with Enhanced Zero Suppression			725 ⁽¹⁾	250	14	16/8
			730 ⁽¹⁾	500	14	16/8
			751	1000-2000	10	8-4/4-2

(1) DPP-ZLE for x725 and x730: Coming Soon

Digitizer Family
724

Supported Firmware

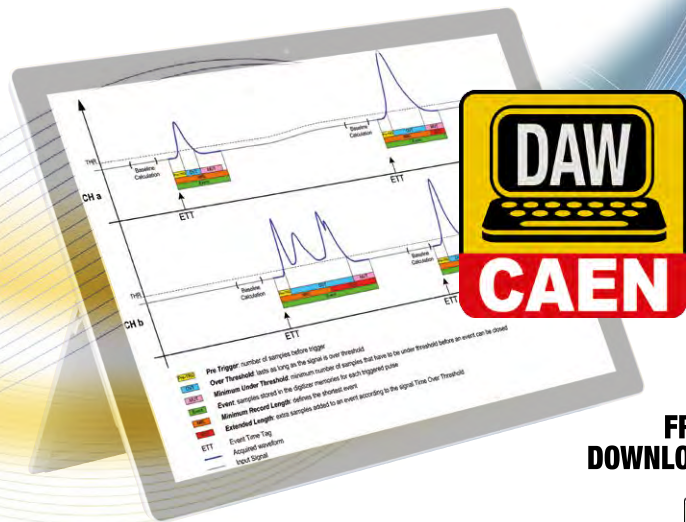
FREE TRIAL
VERSIONFREE
DOWNLOAD

Digital Pulse Processing

DPP-DAW - Channel Independent Zero
Suppression with Dynamic Acquisition Window

NEW

Overview

The Dynamic Acquisition Window (DPP-DAW) firmware has been developed to improve the zero suppression capabilities of the CAEN 724 digitizer family and allow for trigger-less acquisition systems.

By running DPP-DAW firmware, each 724 digitizer channel is able to self-trigger and acquire data independently from the others.

DPP-DAW can dynamically adjust the record length of every triggered event according to its Time Over Threshold to fit the actual duration of the input pulses. This prevents that a pulse larger than the expected gets chopped because of a too short acquisition window.

DPP-DAW is able to continuously evaluate the signal baseline and refer a trigger threshold to its value. Therefore, the threshold can follow the baseline drift of the input signal without changing the trigger conditions of the data acquisition system.

The user can set a minimum record length, a pre-trigger and a minimum not to lose those samples of interest before and after the Time Over Threshold. This allows for a full reconstruction of the digitized pulses.

DPP-DAW can accept an external veto to inhibit the data acquisition. A programmable input delay is available to compensate for the latency due to the veto generation if managed by an external logic unit.

It is possible to store not only the overthreshold part of the significant pulses, but also the samples before and after the threshold crossing points by means of programmable Look Back and Look Ahead windows.

CAEN provides open source demo software for a first approach to DPP-DAW algorithm principles and basic control of the digitizer.

Features

- Independent channel self-trigger
- Automatic adjustment of the acquisition window length to match the actual input pulse duration
- User defined minimum record length and pre-trigger for a complete event reconstruction
- Continuous signal baseline calculation for baseline drift compensation
- Programmable input delay to compensate for veto generation latency
- Channel Trigger Time Tag for event correlation
- Demo software to handle 724 digitizer family running DPP-DAW firmware

Applications

- Neutrino experiments
- Large number of detectors
- Drift chambers, TPC, Cherenkov detectors
- Application requiring an effective data reduction

Ordering Option

Code	Description
WFWPPDAWXA	DPP-DAW - Digital Pulse Processing with Dynamic Acquisition Window (x724)

Features	Firmware	Software	Digitizer Family	Max Sampling Rate (MS/s)	Resolution (bits)	Channels
Digital Waveform Recorder with Zero Suppression for trigger-less acquisition systems			724	100	14	8/4/2

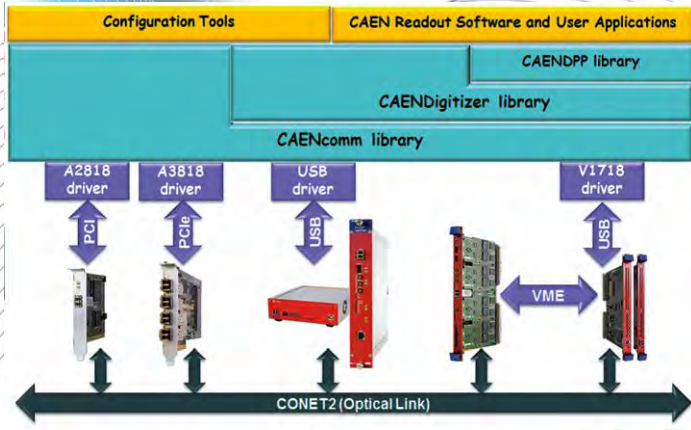

Software Tools

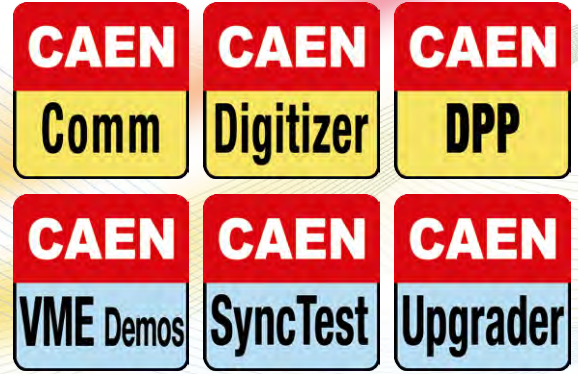

Drivers, Libraries and Configuration Tools

CAEN makes available a family of software tools, compliant to Windows and Linux platforms (32-64 bit), to integrate the hardware into the host PC system, to provide the developer with a middle layer for custom programming, to let the user completely and easily configure and retrieve information from a large number of CAEN boards including digitizers:

Drivers

- Depending on the physical communication channel:
 - USB: USB2.0 compliant
 - Optical Link: proprietary CONET protocol managed by A2818 PCI / A3818 PCIe Controllers
 - VMEbus: accessed by V1718 / V2718 Bridges

Libraries

C and LabVIEW middleware, including demos and examples for user's development.

Configuration Tools

Friendly software applications for the firmware upgrade or to direct access the board registers for a low level full configuration and control.

Type	Library / Tool name	Firmware type		Programming language	Third-party required software	Supported communication channels	Supported boards
		Digital Pulse Processing Firmware	Waveform recording default firmware				
Library	CAEN Comm	*	*	C, LabVIEW (Windows only)	NI LabVIEW Development System	USB, CONET, VMEbus	VME, NIM and Desktop digitizers, Digital MCAs and DT5790, V65xx power supply boards, V1x90x TDCs, Vx495 general purpose VME board and SY2791 TCP readout system
	CAEN Digitizer	*	*	C, LabVIEW (Windows only)	NI LabVIEW Development System	USB, CONET, VMEbus	VME, NIM and Desktop digitizers ^(a) , Digital MCAs and Digital Pulse Analyzer DT5790
	CAEN DPP	*		C		USB, CONET, VMEbus	VME, NIM and Desktop digitizers running DPP-PHA firmware, Digital MCAs
Configuration Tools	CAEN Upgrader	*	*	C, Java	Java Runtime Environment	USB, CONET, VMEbus	VME, NIM and Desktop Digitizers, Digital MCAs and DT5790, V1x90 TDCs, Vx495, V1718/V2718 VME Bridges, V65xx HV Power Supplies, DT55xx HV Power Supplies, A2818/A3818 PCI/PCIe Controllers, SY2791
	CAEN SyncTest		*	C	Gnuplot (Linux only)	USB, CONET, VMEbus	VME digitizers V1720/V1724/V1740/V1751
	CAEN VME Demos	*	*	C/C++, LabVIEW (Windows only)	Microsoft.NET framework, LabVIEW Run-Time Engine	USB, CONET, VMEbus	VME, NIM and Desktop digitizers, V1718/V2718 VME Bridges

(a) The LabVIEW library doesn't support 743 digitizer family and DPP-ZLEplus firmware



Libraries



CAENComm

Interface Library for CAEN Data Acquisition Modules

The purpose of the CAENComm library is to implement a common interface to the higher software layers, masking the details of the physical channel and its protocol, thus making the libraries and applications that rely on the CAENComm independent from the physical layer.

CAENComm is based on CAENVMELib, a library developed specifically for USB-VME bridge (Mod. V1718) and PCI-VME

(Mod. V2718), which implements the basic functions for accessing the VME bus (besides other specific functions for these bridge). For this reason, it is necessary that the CAENVMELib is already installed on your PC before installing the CAENComm; however, the CAENVMELib is completely transparent to the user.

The library pack includes a ready-to-use demo application, Java and LabVIEW version, including source files as reference for user development.



CAENDigitizer

Library of Functions for CAEN Digitizers High Level Management

CAENDigitizer contains the functions to program CAEN boards like Digitizers, Digital MCAs and Digital Pulse Analyzers, to manage the acquisition, execute the readout, unpack the data, send triggers, etc. This library is designed specifically to support both default and DPP firmware.

CAENDigitizer library relies on the CAENComm and

CAENVMELib libraries, allowing to implement a common interface to the higher software layers, masking the details of the physical channel and its protocol. Libraries and applications that rely on the CAENDigitizer become this way independent from the physical layer.

The Library is provided with examples and demo applications, C and LabVIEW version, including source files and sub-VIs as reference for user development.



CAENDPP

High Level Library for CAEN Boards Running DPP Firmware

CAENDPP is a high level library designed to completely control exclusively CAEN digitizers running DPP-PHA firmware and Digital MCAs.

The library allows the user to manage all the relevant board settings, DPP parameters configuration, data acquisition storage. Configuration of synchronized start/stop acquisition is supported in multi-board hardware setup, as well as the single board can be configured for coincidences or anticoincidences

among channels. Histograms are built at the library level and managed through specific library functions; other advanced histogram functions are provided (e.g. histogram recovery). Lists of data can be automatically saved to output files. HV management is also handled by the library, if supported by the board.

CAENDPP is provided with examples and Demo applications, including source files, as reference for user development.





Configuration Tools

CAENUpgrader

FREE DOWNLOAD 



Firmware Upgrade Tool for Front-end Boards Bridges & VME Power Supply

CAENUpgrader is a software tool with a Java Graphical User Interface (for Windows and Linux OS) to easily upgrade the firmware on a large selection of CAEN boards, such as digitizers and MCAs, bridges and controllers, VME power supply boards. It reunites all the functions included in the



cvUpgrade, CAENBridgeUpgrade and PLLConfig CAEN programs, also allowing to configure the PLL settings of VME digitizers (i.e. set the ADC sampling frequency, enable the clock output, etc.), to get the hardware and firmware information and load the license to unlock the pay firmware (e.g. DPP firmware), to control the firmware boot for the NIM and Desktop digitizers.

CAEN VME Demos

FREE DOWNLOAD 



Demo Applications for CAEN Bridges Control

CAEN VME Demos are simple programs developed in C/C++ source code and LabVIEW. Versions featuring friendly graphical interfaces are provided for Windows machines.



represent a starting point for the development of user-specific applications for CAEN Bridges (V1718/VX1718/V2718/VX2718/A2818/A3818) control.

The demos allow for a full board configuration at low level by direct access (read/write) to the registers. Moreover, they

CAEN SyncTest

FREE DOWNLOAD 



Demo Software for CAEN Digitizers Synchronization

CAEN SyncTest is a simple Demo software to demonstrate multi-board synchronization with CAEN VME digitizers running the default firmware. It includes the most relevant commands to adjust the configuration parameters of the boards and read



the acquired event data. It represents an example for setting synchronization and trigger distribution, and is provided as an archive of ANSI C source and header files.

SyncTest can be adapted to different synchronization setup and to different VME Digitizer families.

The NIM-Nuclear Instrumentation Module standard is a very popular form factor widely used in experimental Particle and Nuclear Physics setups. Defined the first time by the U.S. Atomic Energy Commission's report TID-20893 in 1968-1969 is still nowadays widely used in Universities and Research Centers around the world mainly because of its simplicity. CAEN offers a wide selection of NIM instrumentation for test setups and data acquisition.



- | | |
|---------------------------------|------------------------|
| ADCs (Peak Sensing) | Digitizers |
| Analog Pulse Processors | Discriminators |
| Amplifiers (Fast) | Fan In-Fan Out Units |
| Amplifiers (Spectroscopy) | Multichannel Analyzers |
| Attenuators | Scalers |
| Coincidence/Logic/Trigger Units | Timing Units |
| | Translators |

ADCs (Peak Sensing) > Multichannel Analyzers

N957

8k Multichannel Analyzer



Features

- Single input Multichannel Analyzer
- Fully computer controlled MCA
- 8k ADC, fast conversion time with linearization enhancement circuit
- List mode acquisition
- Suitable for HPGe, NaI(Tl), CdTe and other detector types
- USB 2.0 communication interface
- Libraries, Demos (C and LabVIEW) and Software tools for Windows and Linux

Overview

The N957 is an 8k Multichannel Analyzer (MCA) with a USB port, housed in a 1-unit wide NIM module. The MCA performs the function of collecting the input signals and producing an output, in the form of the converted values of the input signal's peaks.

The input pulses can be the ones produced by a standard spectroscopy amplifier's output. They can be Gaussian, semi-Gaussian or square waves, unipolar (positive) or bipolar, in a range from 0 to 10 V, with a rise time greater than 0.1 μ s.

The trigger can be either "on signal" (Auto Gate mode) or "external" (External Gate mode). In the first case a discriminator, with a settable threshold, enables the conversion. In the second case, an external gate is fed to the module via a front panel GATE connector. The input channel has a peak amplitude stretcher, whose output is digitised by a 13-bit ADC featuring a sliding scale technique, to improve the differential non-linearity.

The converted values are stored into a 64 kSamples buffer memory. The unit hosts an USB 2.0 port, which allows a simple control and data-acquisition via PC.

Libraries for Windows and Linux are available.

Firmware upgrade can be performed via USB.

Code	Description
WN957XAAAAA	N957 - 8K Multichannel Analyzer

Analog Pulse Processors

N914

8 Fold Photomultiplier Pulse Processor



Features

- Designed to process signals generated by Photomultipliers
- 8-channel charge preamplifier and integrator
- Dual sensitivity (-0.83 mV/pC and -8.3 mV/pC)
- Built-in discriminator delivers:
 - Majority output
 - Digital signal for arrival times detection
- Sum outputs available

Overview

The N914 is an 8-channel Charge Preamplifier and Integrator, housed in a 1-unit wide NIM module.

It is designed to process signals generated by Photomultipliers. The module is provided with LEMO 00 connectors for both input and output signals, except for the T# output which is available through a 16-pin flat cable connector.

The Photomultiplier signal at the input is buffered and processed in several ways:

- The OL# output provides the signal processed by a gateless charge preamplifier and integrator
- The OH# output provides the signal processed by a gateless charge preamplifier and integrator, followed by a 10x gain stage
- The OLSUM output provides the analog sum of the OL# outputs
- The OHSUM output provides the analog sum of the OH# outputs
- The ASUM output provides the analog sum of the CH# inputs
- The MALU output provides a step function (Majority) with a height proportional to the number of channels simultaneously over a threshold, settable either individually or globally.
- The T_OUT# output provides a discriminator output converted into a digital signal, that can be provided to a TDC input for arrival times recording.

Code	Description
WN914WAAAAA	N914 - 8 fold Photomultiplier Pulse Processor

Amplifiers (Fast)

N978

4 Channel Variable Gain Fast Amplifier



Features

- x10 adjustable gain (x1 steps)
- Input bandwidth up to 250 MHz
- 50 Ω input impedance
- ± 2 V output dynamics
- 50 Ω loads driven
- Cascadeable channels
- Rise/fall time smaller than 1.5 ns
- I/O delay smaller than 3 ns

Overview

The N978 is a 4-channel Fast Rise Time Amplifier, housed in a 1-unit wide NIM module. Each channel features a voltage gain that varies in the range $0 \div 10$.

Channels are non-inverting and bipolar: they amplify both positive and negative signals. Input bandwidth is 250 MHz for signals up to 50 mVpp and decreases for larger ones (up to 100 MHz @ 300 mVpp). Gain setting can be performed independently for each channel via four rotary knobs. Channels can be cascaded in order to obtain larger gain values.

Each channel is provided with three LEMO 00 connectors, one for the input and two bridged for the output. The board features a ± 2 V output dynamics. Four screw-trimmers (one per channel) allow the offset calibration which operates over a ± 30 mV range.

Code	Description
WN978XAAAAA	N978 - 4 Channel Variable Gain Fast Amplifier

Amplifiers (Fast)

N979

16 Channel Fast Amplifier

**Features**

- x10 fixed gain (Optional in x2 ÷ x9 range)
- Input bandwidth up to 250 MHz
- 50 Ω input impedance
- ±2 V output dynamics
- 50 Ω loads driven
- Cascadeable channels
- Rise/fall time smaller than 1.5 ns
- I/O delay smaller than 3 ns

Overview

The N979 is a 16 channel Fast Rise Time Amplifier housed in a 1-unit wide NIM module. Each channel features a fixed voltage gain of 10; fixed gain values in the x2 ÷ x9 range (gain step = 1) are available on request.

Channels are bipolar, non-inverting. Channels can be cascaded in order to obtain larger gain values. Input bandwidth is 250 MHz for signals up to 50 mVpp and decreases for larger ones (up to 130 MHz @ 300 mVpp).

Each channel is provided with three LEMO 00 connectors, one for the input and two bridged for the output. The board features a ±2 V output dynamics. 16 screw-trimmers (one per channel) allow the offset calibration which operates over a ±30 mV range. The features include an input overvoltage protection.

Code	Description
WN979XAAAAA	N978 - 4 Channel Variable Gain Fast Amplifier
WPERS0097902	N979 Customization - Total Gain = x2
WPERS0097903	N979 Customization - Total Gain = x3
WPERS0097904	N979 Customization - Total Gain = x4
WPERS0097905	N979 Customization - Total Gain = x5
WPERS0097906	N979 Customization - Total Gain = x6
WPERS0097907	N979 Customization - Total Gain = x7
WPERS0097908	N979 Customization - Total Gain = x8
WPERS0097909	N979 Customization - Total Gain = x9

N979B

16 Channel Mixed Gain Fast Amplifier

**Features**

- 4 x 4 ch. with different Fixed Gain: x2, x4, x8, x10
- Input bandwidth up to 250 MHz
- 50 Ω input impedance
- ±2 V output dynamics
- 50 Ω loads driven
- Cascadeable channels
- Rise/fall time smaller than 1.5 ns
- I/O delay smaller than 3 ns

Overview

The N979B is a 16 channel fast rise time amplifier housed in a 1-unit NIM module. N979B channels are divided into 4 groups with different fixed gain: x2, x4, x8, x10.

Channels are bipolar, non-inverting. Channels can be cascaded in order to obtain larger gain values. Input bandwidth is 250 MHz for signals up to 50 mVpp and decreases for larger ones (up to 130 MHz @ 300 mVpp).

Each channel is provided with three LEMO 00 connectors, one for the input and two bridged for the output. The board features a ±2 V output dynamics. 16 screw-trimmers (one per channel) allow the offset calibration which operates over a ±30 mV range. The features include an input overvoltage protection.

Code	Description
WN979XBAAAA	N979B - 16 Channel Mixed Gain Fast Amplifier

Amplifiers (Spectroscopy)

N968

Spectroscopy Amplifier

**Features**

- Gain Range continuously variable from 1 to 3000
- Integral non-linearity < ± 0.025% for 2 μs shaping time
- Unipolar output noise < 4.0 μV rms for gain=100 and < 3.5 μV rms for gain=1000 (@ 3μs shaping time)
- Bipolar zero cross-over walk < ± 3 ns (@ 50:1 dynamic range, 2 μs shaping time)
- LED indicator for high precision pole-zero cancellation without using oscilloscope
- Active filter networks with wide range of shaping times
- Gated baseline restorer with automatic controls of threshold and restoring rate
- Pile-up rejector and live-time corrector

Overview

The N968 is a single channel Spectroscopy Amplifier, housed in a 1-unit wide NIM module. It accepts the typical outputs generated from either optical feedback or resistor feedback preamplifiers connected with nuclear particle detectors. The output is quasi Gaussian with 0 to +10 V output dynamics. A front panel switch allows to select between positive and negative input signals. Gain setting can be performed continuously in the 10 ÷ 1500 range, product of Coarse, Fine and Superfine Gain. Two internal jumpers allow to set a x0.1 attenuation and a further x2 amplification, thus extending the gain range to 1 ÷ 3000. The shaping time values are 0.5, 1, 2, 3, 6, 10 μs.

The Pole Zero cancellation is performed via a front panel screw-trimmer. The module features also a Bipolar output (to be used for timing purposes), an advanced Gated Baseline Restorer circuit (with manual or automatic threshold setting) and a Pile Up Rejector which allows to reject piled up events.

Code	Description
WN968XAAAAA	N968 - Spectroscopy Amplifier

Amplifiers (Spectroscopy)

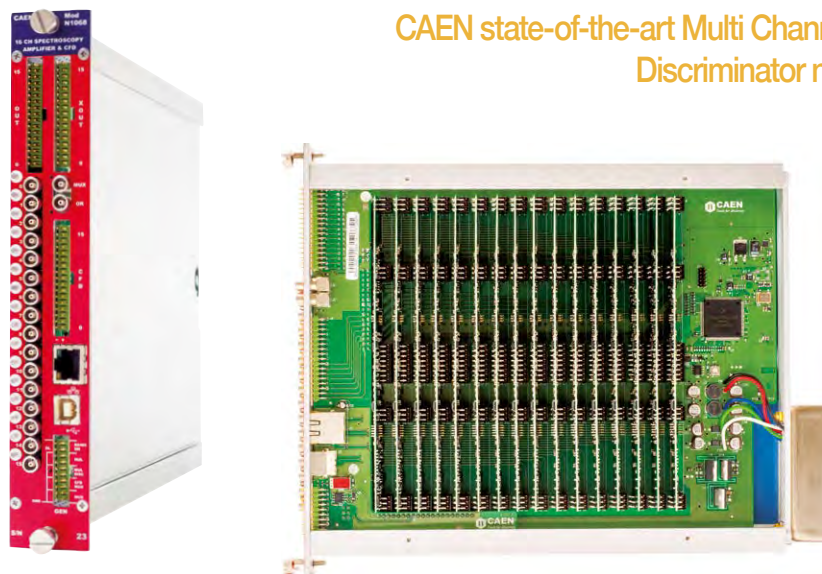
NEW**N1068****16 ch Programmable Spectroscopy Amplifier with Time Filter, CFD and Pile-Up Rejection**

CAEN state-of-the-art Multi Channel Spectroscopy Amplifier & Constant Fraction Discriminator now merged in a single NIM programmable unit.



N1068 Control Software - Channel Setting

Overview

The N1068 is a 16 channel Programmable Spectroscopy Amplifier with Time Filter, CFD and pile-up rejection implemented in a single width NIM module. This module is designed to be used with Silicon, Germanium, and many other detectors types connected to charge sensitive preamplifiers. Also adapted for fast unipolar input signal like PMT and all fast charge detectors. Available dedicated version for germanium detectors: N1068GE (Coming Soon).

The first part of the Amplifier circuits is the polarity selector circuit which select the positive or negative input polarity. Follow two different sections which provide the Energy and Timing information.

The Energy section is composed by a Spectroscopy amplifier with CR-RC5 shaping type and four different time constants (0.5, 1, 2, 4 μ s, extended up to 16 μ s for N1068GE), pole-zero compensation, a 8-step coarse gain (2, 4, 8, 16, 32, 64, 128, 256), a 7-bit fine gain (from 1 to 2) and a DC restorer circuit.

The Timing section is composed by a Timing filter with a differential stage followed by an integration stage both with two time constants. An amplifier stage provides 2 gain value. This timing signal is sent to a Constant Fraction Discriminator section. The CFD has an auto walk compensation and the delay time is selectable individually for each channel by 5 step jumper. The width of CFD OUT is individually programmable from 40 to 1000 ns

A delay on the ECL CFD output are also available. It can be individually Enabled and programmed in a range of 200 ns to 800 ns with 12-bit resolution. The trigger stage foresees a Programmable Multiplicity Trigger and Multiplicity Chaining with a Sum Output available as well.

Pile-up rejection is configurable individually for each channel. When enabled each time a pile-up event occurs, the Energy output is set to the saturation value.

The USB 2.0, Ethernet and RS485 interfaces allow to handle most functional parameters such as Shaping Time, Coarse and Fine Gain, Input Polarity, CFD Thresholds, Pole-Zero Adjustment etc. The board is available in both Single Ended (50 Ω impedance) and Differential (110 Ω impedance) versions.

Features

- 16 channels in a one unit wide NIM module
- Differential and Single ended versions available
- Pile-up rejection
- Programmable input polarity
- ± 4 V input dynamics on 50 and 110 Ω
- Active baseline restorer
- CFD with 5 step delay individually selectable
- Timing filter amplifiers with programmable differentiation and integration time
- CFD, Energy or Timing filter multiplexed output
- Programmable delay on ECL CFD output
- Programmable timing filter amplifiers
- Multiplicity trigger with programmable threshold
- Programmable 4 shaping time per channel
- Programmable fast unipolar input mode for PMT and all fast charge detectors
- Coarse gain and 7 bit fine gain for energy amplifier
- Low Noise
- Programmable pole-zero adjustment
- Fully programmable via USB, Ethernet and RS485
- OR output and Multiplicity output
- Low Power

Code	Description
WN1068SXAAAA	N1068S - 16 ch Programmable Spectroscopy Amplifier and 16 ch CFD Single Ended Inputs
WN1068DXAAAA	N1068D - 16 ch Programmable Spectroscopy Amplifier and 16 ch CFD Differential Inputs
WN1068GEXAAA	N1068GE- 16 ch Programmable Spectroscopy Amplifier and 16 ch CFD for Germanium Detectors

NEW**NEW**

COMING SOON

COMING
SOON

N1168

16 ch Fast Scintillator Programmable Signal Processor and 16 ch CFD

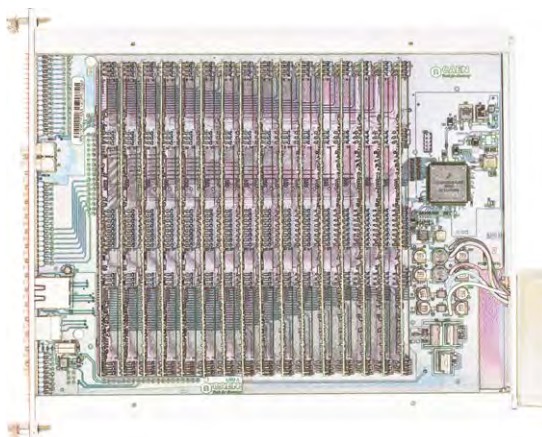
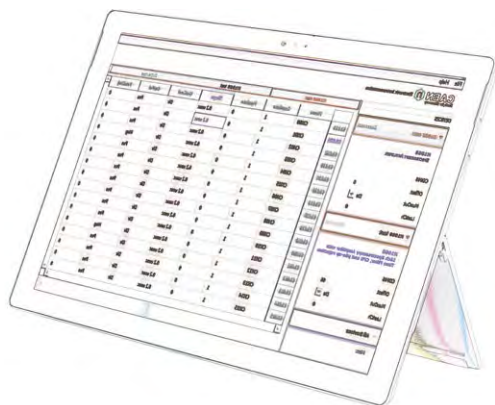

Features

- 16 channels in a one unit wide NIM module
- Fast Slow signal discrimination
- Fast Scintillator application
- Positive or negative inputs hardware selectable on each channel
- Completely programmable via USB, RS485 and Ethernet
- Programmable shaping time per channel
- 4 step coarse gain and 8 bit fine gain for energy amplifier
- 2 gain values for timing amplifier
- 16 energy Gaussian outputs with DC restore
- 16 fast pick Gaussian outputs with DC restore
- 16 channel CFD
- Multiplexed Fast, Slow and CFD output
- Multiplicity output
- OR output
- Multiplicity trigger output
- Pile-up rejector

Overview

The N1168 module is suitable for several type of scintillator detectors particularly where different decay time of the scintillation light are present. This module allows to obtain the full handling of the detector signal giving the total energy, amplitude of the fast component and the time information.

The analysis of the two dimensional spectrum (fast versus total) allows an excellent gamma-neutron separation for liquid scintillators or CLYC detectors, gamma-charged particle separation for BaF₂ detectors and to disentangle the gamma interaction in the different parts of a phoswich detector.

For scintillator detectors with a single light component, the fast output can be used as a second total energy output meeting the requirements of dual energy range experimental setups, avoiding the split of the signal on two shaping amplifiers.

The module is very simple to use and overcome the inconveniences of the standard approach with two gates and QDC setup.

A gate-free fast stretcher circuit captures the leading edge peak value of the signal, that is subsequently Gaussian shaped to allow simple acquisition by a peak-sensing ADC.

The total energy circuit basically consists of an integrator, followed by a Gaussian shaper amplifier.

The time information is given by a Constant Fraction Discriminator with selectable delay line and an automatically walk compensation circuit.

The very low noise level of the module match the requirements of the new class of high energy resolution scintillators (LaBr₃) over a large dynamics energy range applications and also in a very low discrimination level.

(Designed in collaboration with INFN Milano).

Amplifiers (Spectroscopy)

N1568A

16 Ch Programmable Spectroscopy
Amplifier & Dual 16 Ch CFD (30%; 80%)



Accessories

N1568ADAT
USB RS485 Adapter Board



Features

- Positive or negative inputs accepted on each channel
- ± 4 V input dynamics on 50 Ω
- Gain: 0.8 - 182
- 2 bit coarse gain and 192 step fine gain for energy amplifier
- 2 bit coarse gain for timing amplifier
- Programmable (2 bit) shaping time per channel (0.5 \div 4 μ s)
- 8 bit pole zero adjustment
- 16 energy Gaussian outputs (programmable polarity)
- Dual 16 channel CFD (30% constant fraction) ECL output
- 16 channel CFD (80% constant fraction) ECL output
- Libraries, Demos (C and LabVIEW) and Software tools for Windows and Linux

Overview

The N1568A is a 16-channel Spectroscopy Amplifier and dual 16-channel Constant Fraction Discriminator (30% and 80% constant fraction), housed in a 1-unit wide NIM module.

This module is designed to be used with silicon detectors connected to charge preamplifiers, where the measurement of charges collection time allows to obtain the identification in Z of the particles caught by the detector. The rise time is measured via two constant fraction discriminators (30% and 80% of rise time respectively).

Each channel is composed by two sections: Energy section (A) and Timing section (B). The input signal is sent to both sections simultaneously. Section A processes the input signal with a differential circuit, followed by the gain stages (coarse: 2-bit; fine: 192 step), and finally by the shaping. Section B processes the signal with a low noise differential stage (500 ns) followed by a 2-bit programmable linear gain stage; the signal is then fed to two low walk and high resolution Constant Fraction Discriminator sections (30% and 80% constant fraction respectively).

The discriminators share an 8-bit common threshold; the discriminators delay is adjustable via PCB jumpers (6 steps from 15 to 150 ns).

Code	Description
WN1568AXAAAA	N1568A - 16 Ch. Programmable
WN1568ADATXX	N1568 - USB-RS485 Adapter

N568E - N568ELC - N568EB

16 Channel Programmable Spectroscopy
Amplifier



Features

- 16 channels
- Positive or negative inputs accepted on each channel
- Wide gain range: 0.15 to 480 per channel
- Programmable shaping time per channel
- Programmable pole-zero cancellation per channel
- 16 normal or inverted outputs (further 10x amplification outputs also available)
- 16 fast amplifier outputs for timing purposes
- Energy and timing multiplexed outputs
- Completely programmable via USB and Ethernet
- Input noise smaller than 15 μ V RMS @ Gain=100 (N568E)
- Supported by N568E Control Software

Overview

The N568E is a 16 channel spectroscopy amplifier implemented in a single-width NIM module. The following versions are available:

- N568ELC: Shaping time: 0.2, 1, 3, 6 μ s; Equivalent input noise < 25 μ V RMS
- N568E: Shaping time: 0.2, 1, 3, 6 μ s; Equivalent input noise < 15 μ V RMS
- N568EB: Shaping time: 0.1, 0.2, 1, 3 μ s; Equivalent input noise < 15 μ V RMS

For each channel the amplification gain, the output polarity, the shaping time and the pole-zero cancellation, are remotely programmable, either via USB or Ethernet; the RS485 port allows to connect up to 32 daisy chained modules. The gain ranges from 0.15 to 480.

The working parameter values are automatically stored in a non-volatile memory. A semi-Gaussian output is provided either with the programmed gain (OUT) or with a further 10x amplification (XOUT), either direct or inverted. A Common Offset can be programmed via software and allows to shift the baseline of the output. A FOUT output provides a fast amplification for timing purposes (fixed gain factor of 20). A MUX OUT allows to monitor both the OUT and the FOUT outputs of a single channel.

The N568E is supported by freely downloadable N568E Control Software, available for both Windows and Linux OS.

Code	Description
WN568EXAAAA	N568E - 16 Channel Ethernet Prog. Spectroscopy Amplifier (0.2, 1, 3, 6 μ s - 50 Ω)
WN568ELCXAAA	N568ELC - 16 Channel Low Cost Ethernet Prog. Spectroscopy Amplifier (0.2, 1, 3, 6 μ s - 50 Ω)
WN568EXBBAAA	N568EB - 16 Channel Progr. Spectroscopy Amplifier (0.1, 0.2, 1, 3 μ s - 50 Ω)

Attenuators

N858

Dual Attenuator



Features

- Attenuation adjustable from 0 to 44.5 dB
- Input bandwidth larger than 300 MHz
- 100 mW maximum input power
- No power supply required

Overview

The N858 is a dual Attenuator, housed in a 1-unit wide NIM module. Its function is performed by resistive cells, so the module does not require any power supply. Attenuation ranges from 0 to 44.5 dB for each section (0.5 dB steps).

Each section is provided with two LEMO 00 connectors, one for the input (50 Ω impedance) and one for the output, and seven toggle switches for the attenuation settings.

Code	Description
WN858XAAAAA	N858 - Dual Attenuator (0 to 44.5 dB)

Coincidence/Logic/Trigger Units

N113

Dual OR 12 In - 2 Out



Features

- 2 independent OR sections, 12 inputs each
- 1 GATE signal per section
- Cascadeable sections
- Less than 10 ns input/output delay

Overview

The N113 is a dual OR with 12 inputs and 2 outputs per section, housed in a 1-unit wide NIM Module. Via 4 internal jumpers, the module can be converted to a single OR with 24 inputs, with either an independent or a common gate control.

All input/output signals are std. NIM. The outputs can be "gated" via two front panel GATE inputs with their relevant switches.

Code	Description
WN113XAAAAA	N113 - Dual OR 12 In-2 Out

N405

Triple 4-Fold Logic Unit/Majority with VETO



Features

- Three independent sections with 4 standard NIM inputs each
- AND, OR, MAJORITY function selectable for each section
- One auxiliary LIN output per section (width equal to logic function occurrence time)
- NIM shaped outputs with fan-out of 2
- One complementary NIM shaped output per section
- One VETO input per section
- Front panel trimmer for output width adjustment on each section

Overview

The N405 is a triple Logic Unit/Majority, housed in a 1-unit wide NIM module. Its functions are selectable via internal jumpers and external lever switches.

Each section accepts up to 4 input signals and a VETO input and provides 4 outputs (2 normal and 1 complementary, shaped, plus 1 LIN). The LIN output has a duration equal to the occurrence time of the logic function, programmed via the front panel lever switches. The shaped output widths can be set via front panel trimmers in the range from 6 ns to 800 ns.

LOGIC UNIT MODE

Each input signal can be enabled or disabled by means of a front panel lever switch. Each section can be programmed to perform either the AND or the OR functions via front panel switch. When only one input signal is enabled, the section acts as a logic FAN-OUT independently from the selected mode.

MAJORITY MODE

The front panel enable/disable lever switches are used to set the majority level. The AND/OR lever switch must be set in the AND position.

Code	Description
WN405XAAAAA	N405 - Triple 4-Fold Logic Unit/Majority with Veto

Coincidence/Logic/Trigger Units

N455

Quad Coincidence Logic Unit

**Features**

- 4 independent sections
- Two inputs per section
- 130 MHz max. input frequency
- 6 ns double pulse resolution
- 10 ns I/O delay
- Switch selectable AND/OR logical function
- Adjustable output FWHM (4 to 650 ns)
- Overlap output
- Common VETO

Overview

The N455 is a quad Coincidence Logic Unit, housed in a 1-unit wide NIM module.

Each of the 4 sections performs the logic function (AND, OR) selected via the relevant front panel switch.

Each section has 3 normal and 1 complementary NIM shaped outputs with adjustable width via front panel trimmer and an additional overlap output (OVP OUT) whose width is equal to the occurrence time of the logic function.

The OVP OUT allows to obtain an output signal with the minimum input/output delay. A common VETO input signal is available to disable all the output signals.

(ISN-GRENOBLE design)

Code	Description
WN455XAAAAA	N455 - Quad Coincidence Logic Unit

Discriminators

NEW **N605 - 4 Channel 200 MHz**
Constant Fraction Discriminator

Redesigning a classic: the new Constant Fraction Discriminator for fast high performance detectors



N605 rear view

Features

- Four independent Constant Fraction Discriminators for fast detectors with sub-ns rise time
- Independently adjustable discriminators parameters (T, W, Z)
- Double pulse resolving time down to 5 ns
- Fine threshold adjustment from -20 to -1000 mV
- Fine walk correction with zero-crossing adjustment
- Exceptional low walk jitter < 50 ps
- Adjustable output signal width
- CFD monitor output
- Common veto input and individual gates for coincidence or anticoincidence options

Applications

- Fast Scintillators
- PMTs
- Silicon Detectors
- MCP

Overview

The N605 houses four independent 20% Constant Fraction Discriminators (CFD) in 1-unit wide NIM.

The module is intended for high resolution time measurements, where fast signals with rise time as low as 0.8 ns are involved.

Those may involve the use of radiation detectors made of fast scintillators, PMT, microchannel plates and fast semiconductor detectors.

The module guarantees exceptional low walk jitter, lower than 50 ps, for signals spreading over a wide range of amplitude, from -5 V to -50 mV.

The unit is provided with independent threshold discriminators to reject signal baseline noise. Front panel test point and trimmer permits the precise measurement of the threshold, in the range from -20 mV down to -1 V. Each channel can be adjusted for the zero crossing level of the discriminator to minimize the time walk. Moreover the N605 has a CFD signal monitor output connector on the front panel to facilitate the correct adjustment of the working parameters.

Each channel has a fan-out of 3 timing output signals provided with NIM standard. The outputs can be selected to operate both in blocking and updating mode: the first is intended to minimize multiple triggering when slow scintillators are used, while the second is intended to reduce dead time in event of high rate condition. The board is provided with fast VETO input and individual GATE inputs to operate coincidence or anticoincidence logic conditions with the timing signal.

Code	Description
WN605XAAAAA	N605 - 4 Channel 200 MHz Constant Fraction Discriminator

NEW

Discriminators

N840 - N841

8/16 Channel Leading Edge Discriminators

**Features**

- Individually programmable thresholds
- Selectable Updating/Non Updating mode
- Programmable output width
- TEST and VETO inputs
- OR and CURRENT SUM outputs
- 4 digit LED display

Overview

The N840 (N841) is an 8 (16) channel Leading Edge Discriminator, housed in a 1-unit wide NIM module. The module accepts 8 (16) negative inputs and produces 2x8 (2x16) NIM outputs (NIM outputs are provided with a fan-out of 2) and 8 (16) /NIM outputs (complementary) on 24 (48) front panel LEMO 00 connectors.

The pulse forming stage of the discriminator produces an output with adjustable width in a range from 5 ns to 40 ns. Each channel can operate either in Updating or Non-Updating mode according to on-board jumpers position. The discriminator thresholds are individually programmable in a range from -1 mV to -255 mV (1 mV step) via an 8-bit DAC. The minimum detectable signal is -5 mV. The back panel houses VETO and TEST inputs, an OR and a CURRENT SUM output, which provides a current proportional to the input multiplicity, i.e. to the number of channels over threshold, at a rate of -1.0 mA per hit (-50 mV per hit into a 50 Ω load) ±20%.

Settings can be performed via front panel switches and checked via a 4-digit LED display.

Code	Description
WN840XAAAAAA	N840 - 8 Channel Leading Edge Discriminator 50 Ω Negative
WN841XAAAAAA	N841 - 16 Channel Leading Edge Discriminator 50 Ω Negative

N842 - N843

8/16 Channel Constant Fraction Discriminators

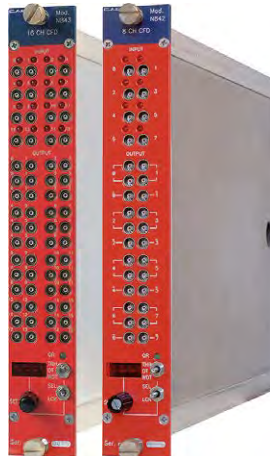
**Features**

- Individually programmable thresholds
- Programmable output width
- Programmable dead time
- TEST and VETO inputs
- OR and CURRENT SUM outputs
- 4-digit LED display

Overview

The N842 (N843) is an 8 (16) channel Constant Fraction Discriminator, housed in a 1-unit wide NIM module. It accepts 8 (16) negative inputs and produces 2x8 (2x16) NIM outputs (provided with a fan-out of 2) and 8 (16) complementary NIM outputs on 24 (48) front panel LEMO 00 connectors.

The constant fraction delay is defined by a delay line network of 20 ns with 5 taps. The timing stage of the discriminator produces an output with adjustable width (range: 16.5 ÷ 273 ns). Moreover, in order to protect against multiple pulsing, it is possible to program a dead time where the module is inhibited from retriggering. The maximum time walk is ±400 ps (for input signals in the range -0.05 ÷ -5 V with 25 ns rise time). The constant fraction value is 20%. The individual thresholds are programmable in a range from -1 to -255 mV (1 mV step) via an 8-bit DAC. The module can operate also with small (< 10 mV) input signals, (in this case the Constant Fraction operation is not performed, i.e. the time walk is higher). The channels' threshold, output width and dead time can be programmed via two lever switches and one rotary switch placed on the front panel. The back panel houses VETO and TEST inputs, an OR and a CURRENT SUM output, which provides a current proportional to the input multiplicity, i.e. to the number of channels over threshold, at a rate of -1.0 mA per hit (-50 mV per hit into a 50 Ω load) ±20%.

Settings can be performed via front panel switches and checked via a 4-digit LED display.

Code	Description
WN842XAAAAAA	N842 - 8 Channel Constant Frac. Discriminator (Delay 20 ns; F = 20%)
WN843XAAAAAA	N843 - 16 Channel Constant Frac. Discriminator (Delay 20 ns; F = 20%)

N844 - N845

8/16 Channel Low Threshold Discriminators

**Features**

- Individually programmable thresholds
- Programmable output width
- TEST and VETO inputs
- OR and CURRENT SUM outputs
- 4-digit LED display
- High sensitivity on small signals

Overview

The N844 (N845) is an 8 (16) channel Low Threshold Leading Edge Discriminator, housed in a 1-unit wide NIM module. The module accepts 8 (16) inputs and produces 2x8 (2x16) NIM outputs (NIM outputs are provided with a fan-out of 2) + 8 (16) /NIM outputs (complementary) on 24 (48) front panel LEMO 00 connectors.

The pulse forming stage of the discriminator produces an output with adjustable width in a range from 6 to 95 ns. The channels operate in updating mode. The discriminator thresholds are individually programmable in a range from -1 mV to -255 mV (1 mV step) via an 8-bit DAC. The minimum detectable signal is -3 mV. A positive input version (Model N844P), with the thresholds programmable in the 1 mV to 255 mV range, is also available. The back panel houses VETO and TEST inputs, a logical OR output (the relevant OR LED lights up if at least one channel is over threshold) and a CURRENT SUM output, which provides a current proportional to the input multiplicity, i.e. to the number of channels over threshold, at a rate of -1.0 mA per hit (-50 mV per hit into a 50 Ω load) ±20%.

Settings can be performed via front panel switches and checked via a 4-digit LED display.

Code	Description
WN844XAAAAAA	N844 - 8 Channel Low Threshold Discriminator 50 Ω Negative Inputs
WN844PXAAAAA	N844P - 8 Channel Low Threshold Discriminator 50 Ω Positive Inputs
WN845XAAAAAA	N845 - 16 Channel Low Threshold Discriminator 50 Ω Negative Inputs
WN844POLEXCH	N844 Polarity Exchange

Fan In-Fan Out Units

N454

4 - 8 Logic Fan In-Fan Out

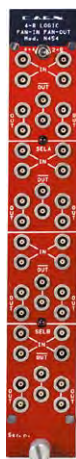

Features

- 4 independent sections with 4 inputs each
- OR output with fan out of four per section
- Possibility of cascading channels to form a dual 8-fold Fan In-Fan Out
- Input/output delay less than 7 ns
- 100 MHz max. input frequency

Overview

The N454 is a quad Logic Fan In-Fan Out, housed in a 1-unit wide NIM module. Each section accepts 4 input NIM signals and performs the logic OR of the inputs. The result of the function is provided as 4 normal and 2 complementary NIM signals via 6 front panel connectors.

The unit can be programmed, via a front panel switch, to operate either as 4 OR sections (4 inputs/4 outputs) or 2 OR sections (8 inputs/8 outputs).

(ISN-GRENOBLE design)

Code	Description
WN454XAAAAA	N454 - 4-8 Logic Fan In-Fan Out

N625

Quad Linear Fan In-Fan Out



Features

- Four independent sections
- Bipolar inputs
- Four 4 Input + 4 Output Fan In-Fan Out sections
- 1 Discriminator Channel featured
- Inverting or non-inverting mode, independently selectable on each section
- 100 MHz bandwidth

Overview

The N625 is a quad Linear Fan In-Fan Out, housed in a 1-unit wide NIM module. Each Fan In-Fan Out section has 4 Inputs and 4 Outputs and provides, on all its output connectors, either the sum of the signals fed to the inputs or its inverted complementary. Fan In-Fan Out inputs are bipolar, while the output can be either inverting or non-inverting (jumper selectable independently for each section). Both input and output signals are DC coupled. Maximum allowed input amplitude is ± 1.6 V. Moreover each Fan In-Fan Out section features a screwdriver trimmer which allows the DC offset adjustment. The module houses also a Discriminator channel, which has one DC coupled input (polarity selectable by jumper). The discriminator threshold is adjustable via screwdriver and monitorable via test point; the output is NIM standard, its width is also adjustable via screwdriver. Front panel LEDs allow to monitor all the mode and gain (i.e. output polarity) adjustments performed via internal jumpers.

Code	Description
WN625XAAAAA	N625 - Quad Linear Fan In-Fan Out

Scalers

N1145

Quad Scaler and Preset Counter / Timer



Features

- Four 8-digit up-counters with 250 MHz max. counting rate
- One 7-digit down-counter with 80 MHz max. counting rate
- NIM and TTL inputs
- One LED display per section
- Up to three sections can be cascaded for 24-digit counting
- Frequency and frequencies ratio measurements
- Individual GATE and RESET per counter
- Manual or pulse triggered RESET

Overview

The N1145 is a quad Scaler and Preset Counter, housed in a 2-units wide NIM module.

The module features four independent 8-digit up-counters, plus a fifth 7-digit down-counter that can be used either as a preset counter or timer.

The counters can have different operating modes and can be variously interconnected, thus allows to use the module as a flexible and powerful tool for several applications involving time, frequency and ratio measurements. All counters accept either TTL or NIM inputs. All control and output signals are standard NIM. The maximum input frequency is 250 MHz and the minimum pulse width is 2 ns for the up-counters, and respectively 80 MHz and 3 ns for the down-counter. All input and output connectors and all control switches are located on the front panel. All input and output connectors are LEMO 00 type.

Code	Description
WN1145XAAAAA	N1145 - Quad Scaler and Preset Counter-Timer

Timing Units

Translators

N93B

Dual Timer

**Features**

- Manual or pulse triggered START (NIM or ECL input)
- Monostable (retriggerable) or bistable operation
- NIM and ECL output pulses from 50 ns to 10 s
- Manual or pulse triggered RESET
- (NIM and ECL) END-MARKER output pulse
- VETO input

Overview

The N93B is a dual Timer, housed in a 1-unit wide NIM module.

Each timer section is a triggered pulse generator which provides NIM and ECL pulses (width from 50 ns to 10 s) when triggered. The output pulses are available both in normal and complementary mode.

Timers can be re-triggered with the END MARKER signal.

The coarse adjustment of the output width can be performed via a 10-position rotary switch, while the fine adjustment can be performed via a precision potentiometer.

The START trigger can be provided either via an external signal or manually via a front panel switch.

N108A

Dual Delay

**Features**

- Delay from 0 to 63.5 ns (+ 1.6 ns offset) per section
- No power supply required
- 0.5 ns steps
- ± 100 ps accuracy on 0.5 to 8 ns delay lines, ± 200 ps on higher lines
- VSWR < 1.15

Overview

The N108A is a dual Delay, housed in a 1-unit wide NIM module. Delay values range from 0 to 63.5 ns (+ 1.6 ns offset) per section, adjustable in 0.5 ns steps. The delay lines consist of calibrated coaxial cables for high accuracy delay and do not require power supply.

N89

NIM - TTL - NIM Adapter

**Features**

- 8 NIM to TTL, 8 TTL to NIM translator channels
- Less than 10 ns Input/Output delay
- 60 MHz max operating frequency
- No duty-cycle limitations

Overview

The N89 is a dual NIM to TTL and TTL to NIM Adapter, housed in a 1-unit wide NIM module. Each section consists of 4 NIM to TTL converters and 4 TTL to NIM converters. All inputs are DC coupled. On each section, a front panel switch allows the output signals to be either normal or complementary. The unit is capable of driving remote 50 Ω loads with minimum signal degradation. Fast rise and fall times (2 ns) ensure reliable performance at minimum pulse width (10 ns) and maximum frequency (60 MHz)

Code	Description
WN93BXAAAAA	N93B - Dual Timer (from CERN type 2255)

Code	Description
WN108AXAAAA	N108A - Dual Delay Unit (1.6 to 65.1 ns)

Code	Description
WN89XXAAAAA	N89 - NIM-TTL-NIM Adapter

Translators

N638

16 Channel NIM-ECL/ECL-NIM Translator and Fan Out



Features

- 16 independent NIM to ECL/NIM and ECL to NIM/ECL channels
- NIM fan-out of 2
- 300 MHz maximum operating frequency
- 2 COMMON IN input with a Fan Out of 16 NIM and 8 ECL
- I/O delay from 1.5 to 3.5 ns, depending on input type

Overview

The N638 is a 16 channel NIM to ECL and ECL to NIM Translator, housed in a 1-unit wide NIM module.

Each of the 16 channels accepts either a NIM or an ECL signal and provides two NIM and one ECL outputs.

The NIM and ECL inputs for each channel are OR-ed prior to Fan Out. The maximum operating frequency is 300 MHz.

Two couples of front panel input bridged connectors accept two COMMON IN NIM signals; each common signal allows the use of the module as a Fan Out of 16 NIM and 8 ECL signals.

Code	Description
WN638XAAAAAA	N638 - 16 Channel NIM-ECL/ECL-NIM Translator and Fan Out

Digitizers



CAEN Digitizers are also available in NIM form factor: for complete information see the Digitizers section.

MCA



CAEN Digital Multichannel Analyzers are also available in NIM form factor: for complete information see the Digital Spectroscopy section.



The Versa Module Eurocard bus is one of the trademarks of CAEN instrumentation catalog. Widely used both in the industry and in the research communities it offers the combination of several qualities such as reliability, robustness and flexibility.

CAEN VME products represent a benchmark both in test and measurements applications and in small and big data acquisition installations.

In the following pages you will find the huge selection of functions that the CAEN modules offer.



ADCs (Peak Sensing)	Fan In-Fan Out Units
Amplifiers (Fast)	I/O Registers
Attenuators	QDCs
Coincidence/Logic/Trigger Units	Scalers
Controllers	TDCs
Digitizers	Timing Units
Discriminators	Translators

ADCs (Peak Sensing)

V1785

8 Channel Dual Range Multievent Peak Sensing ADC

**Features**

- Two simultaneous input ranges: 0 ÷ 4 V / 0 ÷ 500 mV
- 12-bit resolution with 15-bit dynamics
- 125 µV LSB on low range, 1mV LSB on high range
- 2.8 µs / 8 ch conversion time
- 600 ns fast clear time
- Zero and overflow suppression for each channel
- ±0.1% Integral Non Linearity
- ±1.5% Differential Non Linearity
- 32-event buffer memory
- MBLT and CBLT data transfer
- Multicast commands
- Live insertion

Overview

The V1785 is an 8 channel Peak Sensing Analog-to-Digital Converter, housed in a 1-unit wide VME 6U module. Each channel is able to detect and convert the peak value of the positive analog signals (with > 50 ns rise time) provided to the relevant connectors. Accepted input voltage range is 0 ÷ 4 V. Each channel is processed by two gain stages (x1 and x8) operating in parallel, followed by the ADC stage. A dual input range is featured: 0 ÷ 4 V (1 mV LSB) and 0 ÷ 500 mV (125 µV LSB); this allows to avoid saturation with larger input signals while increasing resolution with smaller ones. The ADCs use a sliding scale technique in order to reduce the differential non-linearity.

Programmable zero suppression, multievent buffer memory, trigger counter and test features complete the flexibility of the unit.

The device supports MBLT and CBLT readout modes.

The board features also live insertion, allowing the User to insert (or remove) the board into (or from) the crate without switching the latter off.

Code	Description
WV1785XNCAAA	V1785NC - 8 Ch. Dual Range Multievent PeakSensing ADC

V785 - V785N

32/16 Channel Multievent Peak Sensing ADC

**Features**

- 0 ÷ 4 V input range
- Full 12-bit resolution
- 5.7 µs / 32 ch and 2.8 µs / 16 ch conversion times
- 600 ns fast clear time
- Zero and overflow suppression for each channel
- ±0.1% integral non linearity

Overview

The V785 (V785N) is a 32 (16) channel Peak Sensing Analog-to-Digital Converter, housed in a 1-unit wide VME 6U module. Each channel is able to detect and convert the peak value of the positive analog signals (with > 50 ns rise time) provided to the relevant input connectors (header type for V785, LEMO 00 for V785N). Accepted input voltage range is 0 ÷ 4 V (0 ÷ 8 V for Mod. V785AG, see Ordering Information here below).

The outputs of the peak detecting sections are multiplexed and subsequently converted by two fast 12-bit ADCs (V785: 5.7 µs for all channels, V785N: 2.8 µs for all channels). The integral non linearity is ±0.1% of full scale range (FSR), measured from 2% to 97% of FSR; the differential non linearity is ±1.5% of FSR, measured from 3% to 100% of FSR. The ADCs use a sliding scale technique to reduce the differential non-linearity.

Programmable zero suppression, multievent buffer memory, trigger counter and test features complete the flexibility of the unit.

The device supports MBLT and CBLT readout

Code	Description
WV785XACAAAA	V785AC - 32 Channel Peak Sensing ADC (4V, No 12V DCDC, live ins)
WV785XAGAAAA	V785AG - 32 Channel Peak Sensing ADC (8V, No 12V DCDC, live ins)
WV785XNCAAAA	V785NC - 16 Channel Peak Sensing ADC (4V, No 12V DCDC, live ins)
WA385XAAAAAA	A385 - 16 Channel Cable Adapter (Flat to LEMO) for V785, 50cm ±10% cables

Accessories

A385
16 Channel Flat-to-LEMO
Cable Adapter



- ±1.5% differential non linearity
- 32 event buffer memory
- MBLT and CBLT data transfer
- Multicast commands
- Live insertion

modes.

A 16 channel flat cable to LEMO input adapter (Mod. A385, see Accessories section) is available for the V785 (each V785 requires two A385 adapters for all 32 channels). The boards support a live insertion feature, allowing the User to insert (or remove) the board into (or from) the crate without switching the latter off.

Amplifiers (Fast)

Attenuators

V974

4 Channel Variable Gain Fast Amplifier

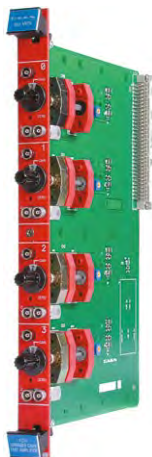
**Features**

- Input bandwidth up to 170 MHz
- x10 adjustable gain with x1 steps
- 50 Ω input impedance
- ± 2 V output dynamics
- Drives 50 Ω loads
- Cascadeable channels
- Rise/fall time <3 ns with a 25 mV unipolar input amplitude

Overview

The V974 is a 4 channel Variable Gain Fast Rise Time Amplifier, housed in a 1-unit wide VME 6U module. The voltage gain for each channel is adjustable, via four rotary switches, from 1 to 10 in x1 steps.

Channels are non-inverting and bipolar: they amplify both positive and negative signals. Input bandwidth is 170 MHz for signals up to 50 mVpp and decreases for larger ones (up to 100 MHz @ 400 mVpp). Channels can be cascaded in order to obtain larger gain values.

Each channel is provided with three LEMO 00 connectors, one for the input and two bridged for the output. The board features a ± 2 V output dynamics. 4 screw-trimmers (one per channel) allow the offset calibration which operates over a ± 25 mV range. The outputs feature a short circuit protection.

The module does not require a VME interface, as it uses only the power lines of the VME crate.

Code	Description
WV974XBAAAA	V974B - 4 Channel Variable Gain Fast Amplifier

V975

8 Channel Fast Amplifier

**Features**

- Input bandwidth up to 250 MHz
- x10 fixed gain
- 50 Ω input impedance
- ± 2 V output dynamics
- Drives 50 Ω loads
- Cascadeable channels
- Rise/fall time <1.5 ns with a 25 mV unipolar input amplitude
- I/O delay <3 ns

Overview

The V975 is an 8 channel Fast Rise Time Amplifier, housed in a 1-unit wide VME 6U module. Each channel has a fixed voltage gain of 10.

Channels are bipolar, non-inverting and can be cascaded in order to obtain larger gain values. Input bandwidth is 250 MHz for signals up to 50 mVpp and decreases for larger ones (up to 110 MHz @ 400 mVpp).

Each channel is provided with three LEMO 00 connectors, one for the input and two bridged for the output. The board features a ± 2 V output dynamics. Screw-trimmers (one per channel) allow the offset calibration which operates over a ± 25 mV range. The outputs feature a short circuit protection.

The module does not require a VME interface, as it uses only the power lines of the VME crate.

Code	Description
WV975XBAAAA	V975B - 8 Channel Fixed Gain Fast Amplifier

V859

Dual Attenuator

**Features**

- Attenuation adjustable from 0 to 44.5 dB
- Cascadeable sections
- Input bandwidth larger than 300 MHz
- 100 mW maximum input power
- No power supply required

Overview

The V859 is a dual Attenuator, housed in a 1-unit VME module. Its function is performed by resistive cells, so the module does not require any power supply. Attenuation ranges from 0 to 44.5 dB for each section (0.5 dB steps). The two sections can be cascaded in order to obtain a single section featuring a 0 ÷ 89 dB (0.5 dB step) attenuation.

Each section is provided with two LEMO 00 connectors, one for the input (50 Ω impedance) and one for the output, and seven toggle switches for attenuation setting. An additional switch allows to cascade the two sections.

Code	Description
WV859XAAAAA	V859 - Dual Attenuator (0 to 44.5 dB)

Coincidence/Logic/Trigger Units

NEW**V2495**
Programmable Logic Unit**Accessories**

A395A



A395B



A395C



A395D



A395E

A967
32 Channel Cable Adapter**Software****Firmware****Overview**

The V2495 is a general purpose programmable FPGA and I/O unit housed in a 1-unit wide VME 6U module. The board is a suitable solution for the implementation of digital functions such as Coincidence, Trigger Logic, Gate and Delay generator, Input/Output Register and more.

The architecture of the V2495 is based on the User FPGA (Altera Cyclone V GX C4, 50K Logic Elements) which is directly interfaced to the front panel I/Os (up to 162 inputs and up to 130 outputs) and to an internal local bus.

The V2495 can be controlled and programmed "on the fly" via the VME Bus or directly through the USB connector on the front panel. A Software tool is provided for free to easily upload the custom Firmware on the User FPGA.

The V2495 is also completed by 32 internal delay lines that can be used to generate programmable gate and delay signals. The channel interface can be freely expanded by adding up to three independent piggyback boards (there are 3 expansion slots interfaced to the User FPGA), choosing between the five available types:

- A395A 32 LVDS/ECL/PECL input channels
- A395B 32 LVDS output channels
- A395C 32 ECL output channels
- A395D 8 NIM/TTL input/output channels
- A395E 8 Analog output 16-bit channels

Therefore, the V2495 can achieve a maximum number of 194 I/O channels.

Features

- User customizable FPGA Unit
- LVDS/ECL/PECL inputs (differential)
- 64 inputs, expandable to 162 (with 32 outputs)
- 32 outputs, expandable to 130 (with 64 inputs)
- 32 independent programmable Gate and Delay Generators
- USB 2.0 Connection
- Libraries (C and LabVIEW) and Software tools for Windows and Linux
- Available in Desktop version DT5495 (coming soon)

A set of free Firmware demos, complete of full source codes, is available to help the user Firmware development. In addition, the unit can be used as a 128 channels Scaler thanks to a specific CAEN Firmware (FW495SC).

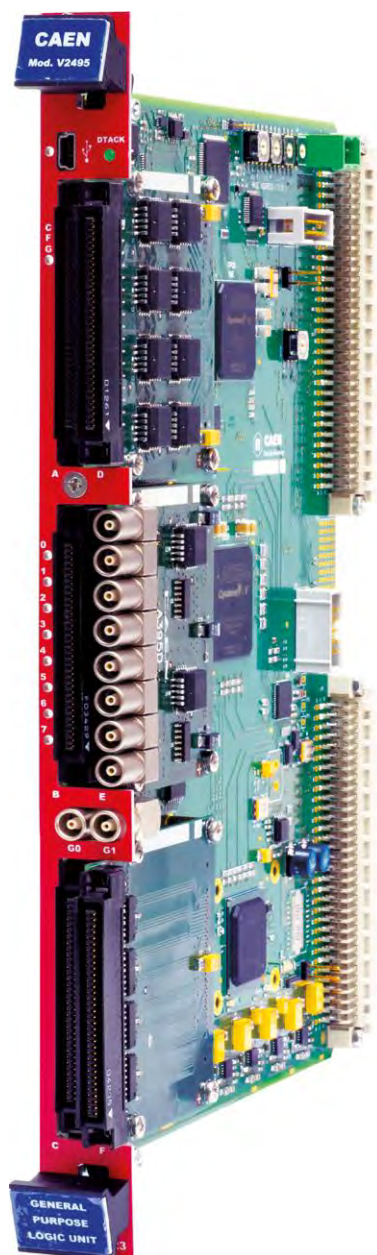

Code	Description	NEW
WV2495XAAAAA	V2495 - VME Programmable Logic Unit	
WA395XAAAAAA	A395A - 32 LVDS/ECL/PECL input channels interface for Vx495 & DT5495	
WA395XBAAAAA	A395B - 32 LVDS output channels interface for Vx495 & DT5495	
WA395XCAAAAA	A395C - 32 ECL output channels interface for Vx495 & DT5495	
WA395XDAAAAA	A395D - 8 NIM/TTL input/output channels interface for Vx495 & DT5495	
WA395XEAAAAA	A395E - 8 channel 16Bit $\pm 5V$ DAC for Vx495 & DT5495	
WA967XAAAAAA	A967 - 32 Channel Cable Adapter (1x32 to 2x16) for V767, V862, V1190, VX1190, Vx495, DT5495	
WFW2495SCXAA	FW2495SC - 128 Channels Latching Scaler for V2495 and DT5495	

Coincidence/Logic/Trigger Units

A395A - A395B - A395C - A395D - A395E

Piggyback boards for Vx495 and DT5495

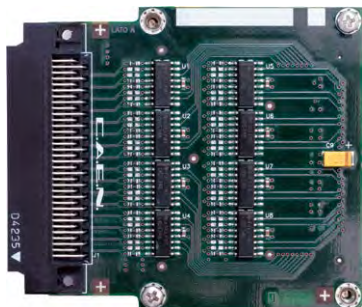

A395A 32 LVDS/ECL/PECL input channels

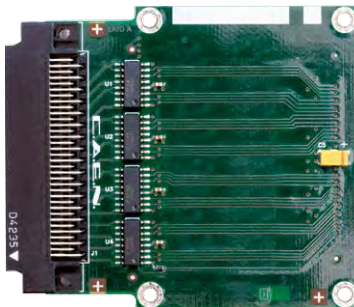

A395B 32 LVDS output channels

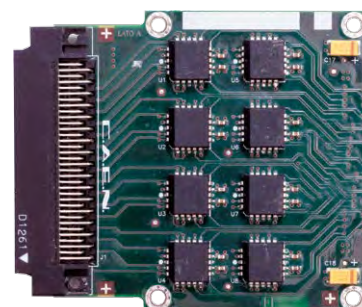

A395C - 32 ECL output channels



A395D 8 NIM/TTL input/output channels

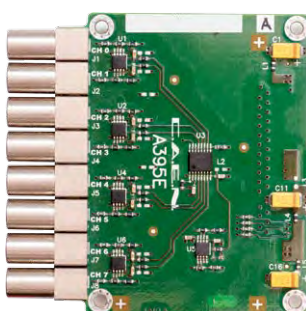

A395E 8 - Analog output 16-bit channels

Piggyback Boards	A395A	A395B	A395C	A395D	A395E
No. of channels	32	32	32	8	8
Channel type	Digital Input	Digital Output	Digital Output	Digital I/O selectable	Analog Output
Description	Differential LVDS/ECL/PECL	Differential LVDS	Differential ECL	NIM/TTL	16-bit resolution Output range: $\pm 5\text{ V}$ @10 k Ω RL $\pm 4\text{ V}$ @200 Ω RL
Note	single ended TTL optional	LVDS 100 Ω RI	ECL	NIM/TTL selectable 50 Ω Rt	DAC board equipped with V1495 Firmware and VHDL source for custom development
Bandwidth	200 MHz	250 MHz	300 MHz	250 MHz	-
Front panel connector	3M P50E-068-P1-SR1 type (34+34) pins	3M P50E-068-P1-SR1 type, (34+34) pins	3M P50E-068-P1-SR1 type, (34+34) pins	LEMO 00	LEMO 00



CAEN Digitizers are also available in VME form factor: for complete information see the Digitizers section.

Scaler Firmware

FW495SC

128 Ch Multievent Latching Scaler

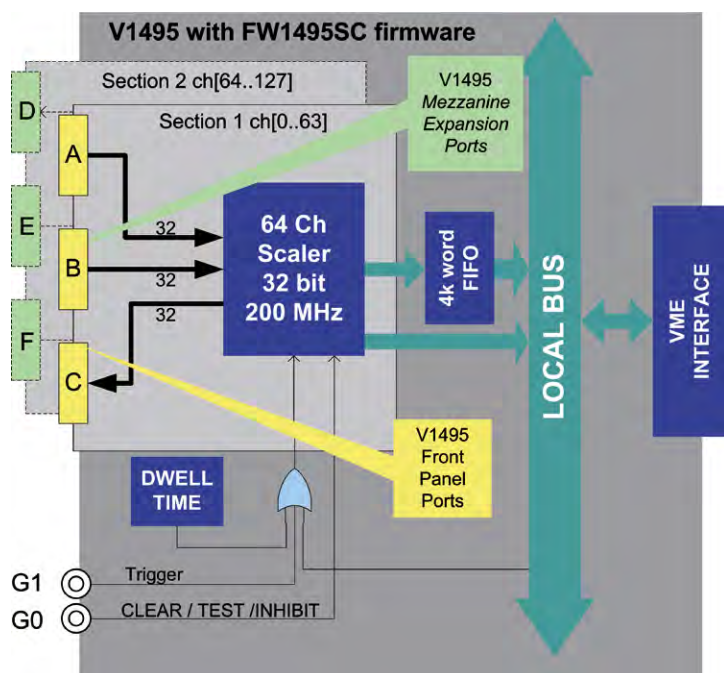
FREE TRIAL
VERSION

Features

- Up to 128 Channel Latching Scaler
- 32-bit channel depth
- Multichannel scaler operation with programmable dwell time from 1 μ s to ~ 1 hour
- 4 k x 32-bit multievent buffer memory
- Trigger time tag
- VME Block Transfer support
- Free Trial version download
- Available version for V1495, V2495 and DT5495

Overview

The FW495SC is a FPGA firmware for CAEN Vx495 and DT5495 models that allows to use these devices as Multievent latching scalers housing up to 128 independent counting channels (this maximum number of channels is achieved if the Vx1495 is expanded with two A395A boards). Each channel has 32-bit counting depth and accepts LVDS/ECL/PECL inputs; the maximum input frequency on V1495 is 250 MHz (if A395D Mezzanine is used), 200 MHz for Motherboard and other Mezzanines.

The board has a FIFO memory that stores the values of the counter, latched "On the fly" at the trigger arrival, while the counting goes on. The Trigger signal can be provided by an external NIM/TTL signal or by a VME request. It is also possible to generate a periodical

Trigger signal by means of an internal programmable timer. The counters can be also read out "On the fly" real time via VME. A programmable General Input signal (NIM / TTL) can be programmed as CLEAR, TEST or VETO (in common for all channels).

Free downloadable FW495SC Trial version.

- The User can download the Trial Version for evaluation.
- The Trial version has a DAQ time frame limitation: every 30 min the user has to restart (Power off/power on) the board.
- To get full functionality the user should purchase a License and register it.
- The procedure is automatic and can be completed on our web site.

Code	Description	
FWF2495SCXAA	FW2495SC - 128 Channels Latching Scaler for V2495 and DT5495	COMING SOON
FWF1495SCXAA	FW1495SC - 128 Channels Latching Scaler for V1495	

Coincidence/Logic/Trigger Units

V976

Quad 4 Fold AND/OR/MAJ, NIM-TTL TTL-NIM Translator, Fan-In Fan-Out



Features

- Four independent sections with four channels each
- TTL and NIM inputs automatically detected
- NIM/TTL selectable output level
- AND, OR, Majority function with selectable number of inputs
- Logic Fan-In / Fan-Out
- Direct or inverted output

Overview

The V976 is a quad Logic Unit/Majority, Level Translator and Fan-In/Fan-Out, housed in a 1-unit wide VME 6U module.

Each section features 4 inputs and 4 outputs on LEMO 00 connectors and can operate as an AND/OR gate or as a 4 channel level translator (NIM to TTL / TTL to NIM). It is possible to use two or four sections together to obtain an 8 or 16 input Majority.

The logic functions can be selected via front-panel and internal switches. Some extra functions, such as a 1 to 12 Fan-Out, can be performed by cascading properly the module's sections.

The module accepts NIM and TTL inputs, while the outputs can be programmed to provide either NIM or TTL levels, either direct or inverted.

The module does not require a VME interface, as it uses only the power lines of the VME crate.

Code	Description
WV976XBAAAA	V976B - Quad 4 Fold AND/OR/MAJ, NIM-TTL TTL-NIM Level Translator and Fan-In Fan-Out

V1718 - VX1718

VME/VME64X VME-USB 2.0 Bridge

Software**Overview**

The V1718 (VX1718) is a VME to USB 2.0 Bridge, housed in a 1-unit wide VME (VME64X) 6U module.

The unit acts as a VME Master module and can be operated from the USB port of a standard PC. It can perform all the cycles foreseen by the VME64 (except those intended for 3U boards). The board can operate as VME System Controller (normally when plugged in the slot 1), acting as a Bus Arbiter in Multi-Master systems.

The VME bus activity can be monitored in detail, both locally (through an LED display) and remotely. The front panel includes also 5 TTL/NIM programmable outputs on LEMO 00 connectors (default assignment is: DS0/1, AS, DTACK, BERR and LOCATION MONITOR) and two programmable TTL/NIM inputs (on LEMO 00 connectors). The I/Os can be programmed via USB in order to implement functions such as Timer, Counter, Pulse Generator, I/O Register, etc.

The PC interface is USB 2.0 compliant, USB data transfer takes place through the High Speed Bulk Transaction protocol; the sustained data rate on the USB is up to 30 MByte/s in MBLT Read cycles. Thanks to the 128 KByte memory buffer, the activity on the VME bus is not slowed down by the transfer rate on the USB port.

The Module is provided with drivers which support the use with the most common PC platforms (Windows Vista, 7/8, Linux). Libraries and useful example programs in C/C++, .NET and LabVIEW are also provided (CAEN VMEDemos software). Firmware upgrade can be performed via USB using CAENUpgrader Tool .

Features

- No boot required, ready at power ON
- Up to 30 MByte/s sustained data transfer rate
- VME Master (arbiter or requester)
- VME Slave (register and test RAM access)
- Cycles: R/W, RMW, BLT, MBLT, IACK, ADO, ADOH
- Addressing: A16, A24, A32, CR/ CSR, LCK
- Data width: D8, D16, D32, D64
- System Controller capabilities
- Interrupt handler
- Front panel Dataway Display (available also from PC and VME)
- 5 outputs and 2 inputs, NIM or TTL, fully programmable
- Libraries, Demos (C and LabVIEW) and Software tools for Windows and Linux
- 2 models available:
 - V1718 (1-unit wide 6U VME)
 - VX1718 (1-unit wide 6U VME64X)

Code	Description
WV1718XAAAA	V1718 - VME-USB 2.0 Bridge
WVX1718XAAAA	VX1718 - VME-USB 2.0 Bridge

Controllers

V2718 - VX2718

VME/VME64X VME-PCI Optical Link Bridge



Accessories

A2818
PCI CONET Controller



A3818
PCI Express CONET2 Controller



AI2700
Optical Fiber Series



Cables for CONET Optical Link Networks

Software



Features

- No boot required, ready at power ON
- PC control through A2818/A3818 Optical Controllers
- CONET1 OR CONET2 CAEN Proprietary Optical link Compatible
- PCI 32-bit/33 Mhz with A2818
- PCIe x8 with A3818
- Daisy chain capability
- Up to 80 MByte/s sustained data transfer rate
- VME Master (arbiter or requester)
- VME Slave (register and test RAM access)
- Cycles: RW, RMW, BLT, MBLT, IACK, ADO, ADOH
- Addressing: A16, A24, A32, CR/CSR, LCK
- Data width: D8, D16, D32, D64
- System Controller capabilities
- Interrupt handler
- Front panel Dataway Display (available also from PC and VME)
- 5 outputs and 2 inputs, NIM or TTL, fully programmable
- Libraries, Demos (C and LabVIEW) and Software tools for Windows and Linux
- 2 models available:
 - V2718 (1-unit wide 6U VME)
 - VX2718 (1-unit wide 6U VME64X)

Overview

The V2718 (VX2718) is a VME to PCI Optical Link Bridge, housed in a 1-unit wide VME (VME64X) 6U module.

The unit acts as a VME Master module and can be controlled by a standard PC equipped with PCI or PCIe CAEN Controller cards (Models A2818 and A3818). The connection between the bridge and the A2818 takes place through an optical fiber cable (AI2700 - Optical Fiber Series). Multi crate sessions can be easily performed, since up to eight daisy chained bridges (via optical fiber cables) can be controlled by a single A2818/A3818, thus building a CONET (Chainable Optical Network).

The device can perform all the cycles foreseen by the VME64 (except those intended for 3U boards). The board can operate as VME System Controller (normally when plugged in the slot 1) acting as a Bus Arbiter in Multi-Master systems. The VME bus activity can be monitored in detail, both locally (through a LED display) and remotely.

The front panel includes also 5 TTL/NIM programmable outputs on LEMO 00 connectors (default assignment is: DS0/1, AS, DTACK, BERR and LOCATION MONITOR) and two programmable TTL/NIM inputs (on LEMO 00 connectors). The I/Os can be programmed via PCI/PCIe in order to implement functions such as Timer, Counter, Pulse generator, I/O register, etc.

The sustained data transfer rate is up to 80 MByte/s. Thanks to the 128 KByte memory buffer, the activity on the VME bus is not slowed down by the transfer rate on the CONET when several bridges units share the same network.

A2818 and A3818 are provided with drivers for Windows Vista/7/8, Linux. Libraries and useful example programs in C/C++, .NET and LabVIEW are also provided. Firmware upgrade can be performed via PCI/PCIe using CAENUpgrader Tool.

Code	Description
WA2818XAAAA	A2818 - PCI Optical Link Controller
WK2718XAAAA	V2718KIT - VME-PCI Bridge (V2718) + PCI Optical Link (A2818) + Optical Fibre 5m duplex (AY2705)
WV2718XAAAA	V2718 - VME-PCI Bridge
WKX2718XAAAA	VX2718KIT - VME-PCI Bridge (VX2718) + PCI Optical Link (A2818) + Optical Fibre 5m duplex (AY2705)
WVX2718XAAAA	VX2718 - VME-PCI Bridge
WA3818XAAAA	A3818 - PCIe 1 Optical Link Controller
WA3818BXAAAA	A3818 - PCIe 2 Optical Link Controller
WA3818CXAAAA	A3818 - PCIe 4 Optical Link Controller
WK2718XBAAAA	V2718KITB - VME-PCI Bridge (V2718) + PCIe Optical Link (A3818A) + Optical Fibre 5m duplex (AY2705)

Discriminators

V812

16 Channel Constant Fraction Discriminator

Accessories

A954
16 Channel to 2x8 Channel
Cable Adapter

**Features**

- Thresholds individually programmable via VME
- Constant fraction for precise discrimination timing
- ECL outputs with fan-out of two
- Programmable output width
- Global VETO and TEST inputs
- Mask register for individual channel enable/disable
- OR, CURRENT SUM and MAJORITY outputs

Overview

The V812 is a 16 channel Constant Fraction Discriminator, housed in a 1-unit wide VME 6U module. The module accepts 16 negative inputs and generates ECL pulses when the input signals exceed a given threshold.

Constant fraction technique allows to precisely determine the timing of the discrimination. The pulse forming stage of the discriminator produces an output pulse with adjustable width (via VME) in a range from 15 ns to 250 ns. Moreover, in order to protect against multiple pulsing, it is possible to program via VME a dead time, from 150 ns to 2 μ s, during which the discriminator is inhibited from retriggering.

The discriminator thresholds can be individually programmed via VME in a range from -1 mV to -255 mV (1 mV step) through an 8-bit DAC. Each channel can be turned on or off via VME by using a mask register.

A CURRENT SUM output provides a current proportional to the input multiplicity, i.e. to the number of channels over threshold, at a rate of -1.0 mA per hit (-50 mV per hit into a 50 Ω load). A MAJORITY output provides a NIM signal if the number of input channels over threshold exceeds the Majority programmed value.

Several V812 boards can be connected in a daisy chain via the CURRENT SUM output: in this case, by switching the majority logic to "External", it is possible to obtain a MAJORITY signal when the number of active channels in the chained modules exceeds a global Majority level. The logic OR of discriminator outputs is available on a front panel NIM signal.

Code	Description
WV812XBAAAA	V812B - 16 Channel Constant Fraction Discriminator
WA954XAAAAA	A954 - 16 Channel to 2x8 Channel Cable Adapter

V814

16 Channel Low Threshold Discriminator

Accessories

A954
16 Channel to 2x8 Channel
Cable Adapter

**Features**

- Thresholds individually programmable via VME
- ECL outputs with fan-out of two
- Non updating operation
- Programmable output width
- Mask register for individual channel enable/disable
- Global VETO and TEST inputs
- OR, CURRENT SUM and MAJORITY outputs
- High sensitivity with small signals
- Negative or Positive input version available

Overview

The V814 is a 16 channel Low Threshold Discriminator, housed in a 1-unit wide VME 6U module. The board accepts 16 negative (positive on request) inputs and produces 16 differential ECL outputs with a fan-out of two on four front panel fat cable connectors. Maximum input frequency is 60 MHz.

The pulse forming stage of the discriminator produces an output pulse whose width is adjustable in a range from 6 to 95 ns via VME. The discriminator thresholds are individually settable in a range from -1 mV to -255 mV (1 mV step), via VME through an 8-bit DAC; a positive input version (Model V814P), with the thresholds settable in the 1 mV to 255 mV range, is also available. Each channel can be turned on or off via VME by using a mask register.

A Current Sum output generates a current proportional to the input multiplicity, i.e. to the number of channels over threshold, at a rate of -1.0 mA per hit (-50 mV per hit into a 50 Ω load). A MAJORITY output connector provides a NIM signal if the number of input channels over threshold exceeds the MAJORITY programmed value.

Several V814 boards can be connected in a daisy chain via the Current Sum output: in this case, by switching the majority logic to External, it is possible to obtain a Majority signal when the number of active channels in the chained modules exceeds a global Majority level. The logic OR of discriminator outputs is available on a front panel NIM signal.

Code	Description
WV814XBAAAA	V814B - 16 Channel Low Threshold Discriminator
WV814XPBAAA	V814PB - 16 Channel Low Threshold Discriminator Positive Inputs
WA954XAAAAA	A954 - 16 Channel to 2x8 Channel Cable Adapter

Discriminators

V895

16 Channel Leading Edge Discriminator



Accessories

A954
16 Channel to 2x8 Channel
Cable Adapter



Features

- Thresholds individually programmable via VME
- ECL outputs with fan-out of two
- Selectable Updating/Non Updating mode
- Programmable output width
- Global VETO and TEST inputs
- Mask register for individual channel enable/disable
- OR, CURRENT SUM and MAJORITY outputs

Overview

The V895 is a 16 channel Leading Edge Discriminator, housed in a 1-unit wide VME 6U module. The board accepts 16 negative (positive on request) inputs and produces 16 differential ECL outputs with a fan-out of two on four front panel fat cable connectors.

Maximum input frequency is 140 MHz. The pulse forming stage of the discriminator produces an output pulse whose width is adjustable in a range from 5 to 40 ns via VME. Each channel can operate either in Updating or Non-Updating mode according to on-board jumpers position.

The discriminator thresholds are individually settable in a range from -1 mV to -255 mV (1 mV step), via VME through an 8-bit DAC. The minimum detectable signal is -5 mV. Each channel can be turned on or off via VME by using a mask register.

A Current Sum output generates a current proportional to the input multiplicity, i.e. to the number of channels over threshold, at a rate of -1.0 mA per hit (-50 mV per hit into a 50 Ω load).

A MAJORITY output connector provides a NIM signal if the number of input channels over threshold exceeds the MAJORITY programmed value. Several V895 boards can be connected in a daisy chain via the Current Sum output: in this case, by switching the majority logic to External, it is possible to obtain a Majority signal when the number of active channels in the chained modules exceeds a global Majority level. The logic OR of discriminator outputs is available on a front panel NIM signal.

Code	Description
WV895XBAAAA	V895B - 16 Channel Leading Edge Discriminator
WA954XAAAAA	A954 - 16 Channel to 2x8 Channel Cable Adapter

Fan In-Fan Out Units

V925

Quad Linear Fan In-Fan Out



Features

- Four independent sections
- Bipolar inputs
- Three 4 In / 4 Out and one 3 In / 3 Out sections
- One Discriminator channel
- Inverting or non-inverting mode independently selectable on each section
- 120 MHz bandwidth

Overview

The V925 is a Quad Linear Fan In-Fan Out, housed in a 1-unit wide VME 6U module. The board features three 4 In/ 4 Out and one 3 In/ 3 Out sections; one Discriminator channel is also featured. Each Fan In-Fan Out section produces, on all its output connectors, the sum of the signals fed to the inputs, which can also be inverted. Fan In/Fan Out inputs are bipolar, while the output can be either inverting or non inverting (jumper selectable independently for each section). Both input and output signals are DC coupled.

Maximum input amplitude is ± 1.6 V. Moreover each Fan In-Fan Out section features a screwdriver trimmer which allows the DC offset adjustment. The discriminator channel has one DC coupled input (trigger slope leading/trailing is jumper selectable), the threshold is screwdriver adjustable and monitorable via test point; the output is NIM standard, its width is screwdriver adjustable. Front panel LEDs allow to monitor all the mode, gain and polarity adjustments performed via internal jumpers.

Code	Description
WV925XAAAAA	V925 - Quad Linear Fan In-Fan Out

I/O Registers

V977

16 Channel I/O Register (Status A)

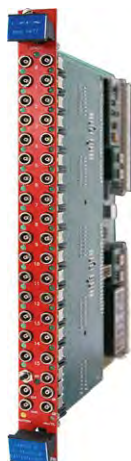
**Features**

- NIM and TTL inputs/outputs
- Individual channel enabling/disabling
- Software Input/Output generation
- Fully programmable RORA Interrupter
- Pushbutton TEST signal
- Status A capabilities
- Live insertion

Overview

The V977 is a 16 channel Input/Output Register, housed in a 1-unit wide VME 6U module. The board can operate either as a 16 channel general purpose I/O Register or as Multihit Pattern Unit; the operating mode is selected via VME and is signalled via front panel LEDs.

The module has 16 Inputs/Outputs; an on-board switch allows to select between NIM and TTL output signals, while NIM and TTL input signals are both accepted; 2 LEDs signal the I/O status for each channel. The module features an additional channel (TEST CHANNEL), which allows to send a test pulse via a front panel pushbutton.

Input channels can be individually/globally masked via VME or globally via a front panel GATE input. The channel status can be cleared either via VME or via the front panel common CLEAR input.

The channels global OR and /OR outputs are available as front panel signals and can be eventually masked. GATE and CLEAR signals can be either NIM or TTL; OR and /OR can be set at NIM or TTL level in the same way of the output channels. Live insertion is also supported.

Code	Description
WV977XBAAAA	V977B - 16 Channel I/O Register (Status A)

QDCs

V792 - V792N

32/16 Channel Multievent QDC

Accessories

A392
16 Channel LEMO
Adapters



A992
16 Channel Impedance
Adapter

**Features**

- 0 ÷ 400 pC input range
- Full 12-bit resolution
- 100 fC LSB
- 5.7 μ s / 32 ch and 2.8 μ s / 16 ch conversion times
- 600 ns fast clear time
- Zero and overflow suppression for each channel
- \pm 0.1% integral non linearity
- \pm 1.5% differential non linearity
- 32 event buffer memory
- MBLT and CBLT data transfer
- Multicast commands
- Live insertion
- Libraries (C and LabVIEW) and Software tools for Windows and Linux

Overview

The V792 (V792N) is a 32 (16) channel Multievent QDC, housed in a 1-unit wide VME 6U module. The board features 32 (16) Charge-to-Digital Conversion (Integrating ADC) channels. The inputs of the board are 50 Ω terminated and can only accept negative current pulses. For each channel, the input charge is fed via flat cable header (LEMO 00 connectors for V792N) and converted to a voltage level by a QAC (Charge to Amplitude Conversion) section. Input range is 0 ÷ 400 pC. The outputs of the QAC sections are multiplexed and subsequently converted by two fast 12-bit ADCs. The integral non linearity is \pm 0.1% of Full Scale Range (FSR) measured from 5% to 95% of FSR. The ADCs use a sliding scale technique to improve the differential non-linearity.

The device supports MBLT and CBLT readout modes. Live insertion is also supported. A 16 ch. decoupling board (A992, see Accessories section) is available for the V792 to avoid ground loops and signal reflections when long flat cable (110 Ω) connections to the 50 Ω inputs are used (one V792 requires two A992 boards). A 16 channel flat cable to LEMO input adapter (A392, see Accessories section) is also available for the V792 (one V792 requires two A392 boards).

Code	Description
WV792XACAAAA	V792AC - 32 Channel Multievent QDC (No 12V DCDC, live ins)
WV792XNCAAAA	V792NC - 16 Channel Multievent QDC (No 12V DCDC, live ins)
WA385XAAAAAA	A385 - 16 Channel Cable Adapter (Flat to LEMO) for V785, 50cm \pm 10% cables
WA392XAAAAAA	A392 - 16 Channel Cable Adapter (Flat to LEMO) for V792, 50cm \pm 10% cables
WA385XMAAAAA	A385M - 16 Channel Cable Adapter (Flat to LEMO) for V785, 1m \pm 10% cables
WA392XMAAAAA	A392M - 16 Channel Cable Adapter (Flat to LEMO) for V792, 1m \pm 10% cables
WA992XAAAAAA	A992 - 16 Channel Impedance Adapter for V792

QDCs

V862

32 Channel Multievent Individual Gate QDC

**Accessories**

A967
32 Channel Cable Adapter

**Features**

- Individual Gate input per channel
- 0 ÷ 400 pC input range
- Full 12-bit resolution
- 100 fC LSB
- 5.7 μ s / 32 ch conversion time
- 600 ns fast clear time
- Zero and overflow suppression for each channel
- $\pm 0.1\%$ integral non linearity
- $\pm 1.5\%$ differential non linearity
- 32 event buffer memory
- MBLT and CBLT data transfer
- Multicast commands
- Live insertion
- Libraries (C and LabVIEW) and Software tools for Windows and Linux

Overview

The V862 is a 32 channel Multievent QDC, housed in a 1-unit wide VME 6U module. The board features 32 Charge-to-Digital Conversion (Integrating ADC) channels. The inputs of the board are 50 Ω terminated and can only accept negative current pulses. Each channel has an independent gate input (GATE I) logically ANDed with a COMMON GATE input; the input charge on the i-th channel is converted to a voltage level by a QAC (Charge to Amplitude Conversion) section when both the GATE I and COMMON GATE signals are active. Input range is 0 ÷ 400 pC. The integral non linearity is $\pm 0.1\%$ of full scale range (FSR), measured from 2% to 97% of FSR; the differential non linearity is $\pm 1.5\%$ of FSR, measured from 3% to 100% of FSR. The ADCs use a sliding scale technique to reduce the differential non-linearity.

The outputs of the QAC sections are multiplexed and subsequently converted by two fast 12-bit ADCs (5.7 μ s for 32 channels). The V862 offers a 32 event buffer memory; programmable zero suppression and trigger counter complete the features of the unit. The device supports MBLT and CBLT readout modes. Live insertion is also supported.

Code	Description
WV862XACAAAA	V862AC - 32 Channel Multievent QDC With Individual Gate (live insertion)
WA967XAAAAAA	A967 - 32 Channel Cable Adapter (1x32 to 2x16) for V767, V862, V1190, VX1190, Vx495, DT5495

V965 - V965A

16/8 Channel Dual Range Multievent QDC

**Features**

- Two simultaneous ranges: 0 ÷ 900 pC / 0 ÷ 100 pC
- 12-bit resolution with 15-bit dynamics
- 25 fC LSB on low range, 200 fC LSB on high range
- 2.8 μ s / 8 ch conversion time
- 600 ns fast clear time
- Zero and overflow suppression for each channel
- $\pm 0.1\%$ Integral non linearity
- $\pm 1.5\%$ Differential non linearity
- 32 event buffer memory
- MBLT and CBLT data transfer
- Multicast commands
- Live insertion
- Libraries, Demos (C and LabVIEW) and Software tools for Windows and Linux

Overview

The V965 (V965A) is a 16 (8) channel Dual Range Multievent QDC, housed in a 1-unit wide VME 6U module. The board features 16 (8) Charge-to-Digital Conversion Integrating ADC channels. The inputs of the board are 50 Ω terminated and can only accept negative current pulses.

For each channel, the input charge is converted to a voltage level by a QAC (Charge to Amplitude Conversion) section. Each QAC output is then converted by two ADCs in parallel; one ADC is preceded by a x1 gain stage, the other by a 9x gain stage. A dual input range is then featured: 0 ÷ 900 pC (200 fC LSB) and 0 ÷ 100 pC (25 fC LSB); this allows to avoid saturation with big charge pulses while increasing resolution with small ones.

The outputs of the QAC sections are multiplexed and subsequently converted by two fast 12-bit ADCs. The ADCs use a sliding scale technique to improve the differential non-linearity. Programmable zero suppression, multi-event buffer memory, trigger counter and test features complete the flexibility of the unit.

The device supports MBLT and CBLT readout modes. Live insertion is also supported.

Code	Description
WV965XBAAAAA	V965 - 16 Channel Dual Range Multievent QDC (No 12V DCDC, live ins)
WV965AXBAAAA	V965A - 8 Channel Dual Range Multievent QDC (No 12V DCDC, live ins)

Scalers

V830

32 Channel Latching Scaler

Accessories

A954
16 Channel to 2x8 Channel
Cable Adapter



Features

- Available with either ECL or LVDS inputs
- 250 MHz counting frequency
- 32-bit channel depth
- Multichannel scaler operation with programmable dwell time from 1.2 μ s to 1700 s
- MBLT and CBLT data transfer
- Multicast commands
- 32k x 32-bit multievent buffer memory
- Live insertion

Overview

The V830AC is a 32 channel Multievent Latching Scaler, housed in a 1-unit wide VME 6U module.

Each channel has 32 bits counting depth and accepts ECL inputs (LVDS on V830LC, see ordering options); the maximum input frequency is 250 MHz. The counters' values can be read on the fly via VME without interfering on data acquisition process.

The V830 is equipped with a 32k x 32-bit multievent buffer memory which may be used to store and readout accumulated data during subsequent counting.

The Trigger signal can be provided by an external NIM/ECL signal or by a VME request. It is also possible to generate a periodical Trigger signal by means of an internal programmable timer.

The module features VETO and CLEAR ECL inputs and a TEST NIM input (in common for all channels).

The device supports MBLT and CBLT readout modes. Live insertion is also supported.

Code	Description
WV830XACAAA	V830AC - 32 Channel 32 Bit Scaler 250 MHz (With FIFO) ECL inputs
WV830LXCAAAA	V830LC - 32 Channel 32 Bit Scaler 250 MHz (With FIFO) LVDS inputs
WA954XAAAAA	A954 - 16 Channel to 2x8 Channel Cable Adapter

TDCs

V1190-2eSST Family

128/64 Channel Multihit TDC (100/200/800 ps)

Accessories

A967
32 Channel Cable Adapter



Software

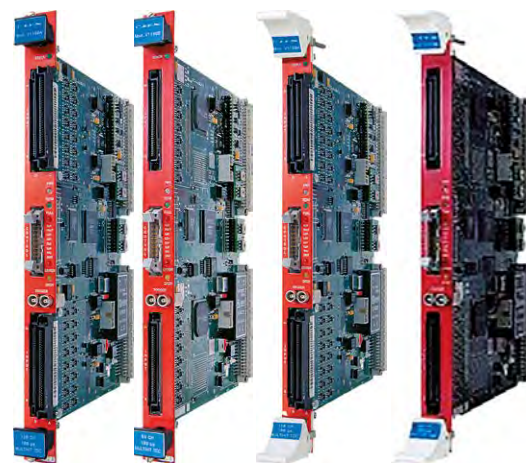

Features

- 3 programmable ranges: 100 ps LSB (19-bit resolution), 200 ps LSB (19-bit) and 800 ps LSB (17-bit)
- 4 models available:
 - V1190A-2eSST: 128 ch. (6U VME)
 - VX1190A-2eSST: 128 ch. (6U VME64X)
 - V1190B-2eSST: 64 ch. (6U VME)
 - VX1190B-2eSST: 64 ch. (6U VME64X)
- ECL/LVDS inputs automatically detected
- 5 ns Double Hit Resolution
- Leading and Trailing Edge detection
- Trigger Matching and Continuous Storage acquisition modes
- 32k x 32-bit output buffer
- MBLT, CBLT and 2eSST data transfer
- Multicast commands
- Live insertion
- Libraries, Demos (C and LabVIEW) and Software tools for Windows and Linux

Overview

The boards of V1190-2eSST TDC family house 64/128 independent Multi-Hit/Multi-Event Time to Digital Conversion channels. The units feature High Performance Time to Digital Converter chips developed by CERN. LSB can be set at 100 ps (19-bit resolution, 52 μ s FSR), 200 ps (19-bit, 104 μ s FSR) or 800 ps (17-bit, 104 μ s FSR).

The V1190-2eSST is available in 4 different versions:

- V1190A-2eSST: 128 channels (1-unit wide 6U VME)
- VX1190A-2eSST: 128 channels (1-unit wide 6U VME64X)
- V1190B-2eSST: 64 channels (1-unit wide 6U VME)
- VX1190B-2eSST: 64 channels (1-unit wide 6U VME64X)

The channels can be enabled for the detection of hits rising/falling edges or for their width measurement (both the edges' timing, and the hit width can be measured with the selected resolution). For each channel there is a digital adjustment for the zeroing of any offsets. The data acquisition can be programmed in "Events" ("Trigger Matching Mode", with a programmable time window) or in "Continuous Storage Mode". Both ECL and LVDS input signals are supported.

The board houses a 32k x 32-bit deep Output Buffer, that can be readout via VME in a completely independent way from the acquisition itself.

The device supports MBLT, CBLT and 2eSST readout modes. Live insertion is also supported.

Code	Description
WA967XAAAAA	A967 - 32 Channel Cable Adapter (1x32 to 2x16) for V767, V862, V1190, VX1190, Vx495, DT5495
WVX1190AEXAE	VX1190A - 2eSST 128 Ch. Multievent Multihit TDC 100-200-800 psec ECL/LVDS
WVX1190BEXAE	VX1190B - 2eSST 64 Ch. Multievent Multihit TDC 100-200-800 psec ECL/LVDS
WV1190AEXAAE	V1190A - 2eSST 128 Ch. Multievent Multihit TDC 100-200-800 psec ECL/LVDS
WV1190BEXAAE	V1190B - 2eSST 64 Ch. Multievent Multihit TDC 100-200-800 psec ECL/LVDS

V1290-2eSST Family

32/16 Channel Multihit TDC

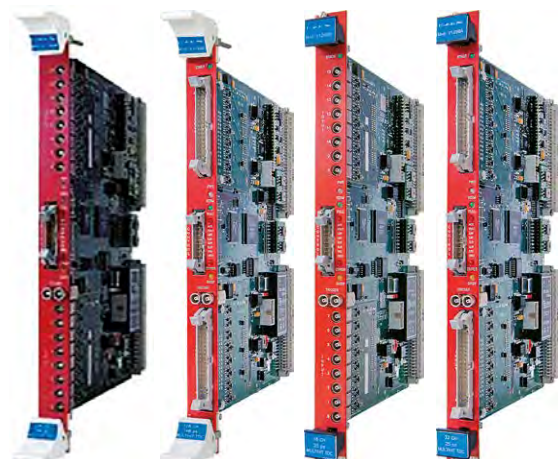

Overview

The boards of V1290-2eSST TDC family house 16/32 independent Multi-Hit/Multi-Event Time to Digital Conversion channels. The unit features High Performance Time to Digital Converter chips developed by CERN. LSB is 25 ps (21-bit resolution, 52 μ s FSR). The module accepts both ECL and LVDS inputs (NIM inputs on V1290N e VX1290N).

The V1290-2eSST is available in 4 different versions:

- V1290A-2eSST: 32 channels (1-unit wide 6U VME)
- VX1290A-2eSST: 32 channels (1-unit wide 6U VME64X)
- V1290N-2eSST: 16 channels (1-unit wide 6U VME)
- VX1290N-2eSST: 16 channels (1-unit wide 6U VME64X)

The channels can be enabled for the detection of hits rising/falling edges. For each channel there is a digital adjustment for the zeroing of any offsets. The data acquisition can be programmed in "Events" ("Trigger Matching Mode", with a programmable time window) or in "Continuous Storage Mode".

The board houses a 32k x 32-bit deep Output Buffer, that can be readout via VME in a completely independent way from the acquisition itself.

The device supports MBLT, CBLT and 2eSST readout modes. Live insertion is also supported.

Software



Accessories

A954
16 Channel to 2x8 Channel
Cable Adapter



Features

- 4 models available:
 - V1290A-2eSST: 32 ch. (6U VME)
 - VX1290A-2eSST: 32 ch. (6U VME64X)
 - V1290N-2eSST: 16 ch. (6U VME)
 - VX1290N-2eSST: 16 ch. (6U VME64X)
- 25 ps LSB
- 21-bit resolution
- 52 μ s full scale range
- 5 ns Double Hit Resolution
- Leading and Trailing Edge detection
- Trigger Matching and Continuous Storage acquisition modes
- 32k x 32-bit output buffer
- MBLT, CBLT and 2eSST data transfer
- Multicast commands
- Live Insertion
- Libraries, Demos (C and LabVIEW) and Software tools for Windows and Linux

Code	Description
WVX1290AEXAE	VX1290A - 2eSST 32 Ch. Multievent Multihit TDC 25 psec E CL/LVDS
WVX1290BNXAE	VX1290N - 2eSST 16 Ch. Multievent Multihit TDC 25 psec NIM
WV1290AEXAAE	V1290A - 2eSST 32 Ch. Multievent Multihit TDC 25 psec ECL/LVDS
WV1290BNXAAE	V1290N - 2eSST 16 Ch. Multievent Multihit TDC 25 psec NIM
WA954XAAAAAA	A954 - 16 Channel to 2x8 Channel Cable Adapter

TDCs

V775 - V775N

32/16 Channel Multievent TDC

Accessories

A954
16 Channel to 2x8 Channel
Cable Adapter



Features

- Full scale range programmable from 140 ns to 1.2 μ s
- 12-bit resolution with 15-bit dynamic range
- 35 ps LSB
- 5.7 μ s / 32 ch and 2.8 μ s / 16 ch conversion times
- 600 ns fast clear time
- Zero and overflow suppression for each channel
- $\pm 0.1\%$ integral non linearity
- $\pm 1.5\%$ differential non linearity
- 32 event buffer memory
- MBLT and CBLT data transfer
- Multicast commands
- Libraries, Demos (C and LabVIEW) and Software tools for Windows and Linux

Overview

The V775 (V775N) is a 32 (16) Channel Multievent TDC, housed in a 1-unit wide VME 6U module. The Full Scale Range can be selected via VME from 140 ns to 1.2 ms with 8-bit resolution. The board can operate both in COMMON START and in COMMON STOP mode. Each time interval between the COM signal and the input signal is converted into a voltage level by the TAC sections. The outputs of the TAC sections are multiplexed and subsequently converted by two fast ADC modules (5.7 ms conversion time). The V775N houses 16 channels on LEMO 00 connectors and shares most of its features with the Mod. V775.

The integral non linearity is $\pm 0.1\%$ of full scale range (FSR), measured from 2% to 95% of FSR; the differential non linearity is $\pm 1.5\%$ of FSR, measured from 3% to 100% of FSR. The ADCs use a sliding scale technique to reduce the differential non-linearity.

Programmable zero suppression, multievent buffer memory, trigger counter and test features complete the flexibility of the unit. The devices support MBLT and CBLT readout modes.

Code	Description
WV775XACAAAA	V775AC - 32 Channel Multievent TDC (No 12V DCDC, No live ins)
WV775XNCAAAA	V775NC - 16 Channel Multievent TDC (No 12V DCDC, No live ins)
WPERS0077501	V775 Customization - 12 μ S Full Scale
WA954XAAAAAA	A954 - 16 Channel to 2x8 Channel Cable Adapter

Timing Units

V972

Delay Unit



Features

- Completely passive delay via a set of calibrated coaxial cable stubs (50 Ω)
- 0 to 31.5 ns delay with 2.6 ns offset
- 0.5 ns resolution
- ± 100 ps accuracy on 0.5 to 8 ns delay steps; ± 200 ps accuracy on 16 ns step
- VSWR < 1.15

Overview

The V972 is a Delay Unit housed in a 1-unit wide VME 6U module. Delay values range from 0 to 31.5 ns (+ 2.6 ns offset), adjustable in 0.5 ns steps via front panel toggle switches. The delay lines consist of calibrated coaxial cables for high accuracy delay and do not require power supply.

Code	Description
WV972XAAAAAA	V972 - Delay Unit (2.6 to 34.1 ns)

Timing Units

V993C

Dual Timer



Features

- Manual or pulse triggered START (NIM, TTL or ECL)
- Monostable (re-trigger) or bistable operation
- NIM, TTL and ECL output pulses from 50 ns to 10 s
- Manual or pulse triggered RESET
- (NIM, TTL and ECL) END-MARKER pulse
- VETO input

Overview

The V993C is a Dual Timer, housed in a 2-Unit wide VME module.

Each timer section is a triggered pulse generator which provides NIM/TTL (NIM/TTL selection is performed via an on board switch) and ECL pulses (width from 50 ns to 10 s) when triggered. The output pulses are available both in normal and complementary mode.

Timers can be re-triggered with the END MARKER signal.

The coarse adjustment of the output width can be performed via a 9-position rotary switch, while the fine adjustment can be performed either via a 15 turn dial handle (with lock) or by providing an external voltage. The START trigger can be provided either via an external signal (NIM, TTL or ECL) or manually via a front panel switch.

The module features also VETO and RESET input signals. RESET is also available on a front panel switch.

The V993C is equipped with LEMO 00 connectors for NIM/TTL signals and male pin couples for ECL signals.

Code	Description
WV993XCAAAAA	V993C - Dual Timer

Translators

V538A

8 Channel NIM-ECL/ECL-NIM Translator



Accessories

A954
16 Channel to 2x8 Channel
Cable Adapter



Features

- 8 independent NIM to ECL/NIM and ECL to NIM/ECL channels
- NIM and ECL fan-out of 2
- 300 MHz maximum operating frequency
- COMMON IN input with a fan-out of 16 (both NIM and ECL)
- I/O delay <5 ns

Overview

The V538A is an 8 channel NIM-ECL/ECL-NIM Translator, housed in a 1-unit wide VME module. Each of the 8 channels accepts a NIM or ECL signal and provides two NIM and two ECL outputs (OUT 0 ÷ 7 A, B). The NIM and ECL inputs of each channel are ORed prior to fan-out. The maximum operating frequency is 300 MHz.

Two front panel input bridged connectors accept a COMMON IN NIM signal, which allows the use of the module as a fan-out of 16 NIM and 16 ECL signals.

Code	Description
WV538XBAAAA	V538AB - 8 Channel NIM-ECL/ECL-NIM Translator
WA954XAAAAA	A954 - 16 Channel to 2x8 Channel Cable Adapter



The preamplifier is usually the first stage in the electronic chain and its role is to amplify the detector signal to a level suitable for further electronic modules. Timing and amplitude characteristics of the preamplified signals are really important features and depend on the user needs. The right choice of a preamplifier is the first step to be taken for making a good data acquisition chain. CAEN offers a selection of preamplifiers for both small applications and big nuclear/subnuclear physics experiments.



Charge Sensitive Preamplifiers

Fast Preamplifiers

Wideband Amplifiers

Preamplifier Power Supplies

Charge Sensitive Preamplifiers

A422A

Charge Sensitive Preamplifier with Timing



Features

- Positive or negative input signals
- Energy sensitivity range of 5, 30 or 60 mV/MeV (Si equivalent)
- Low noise
- Timing output
- Up to 5 kV (positive or negative) detector bias voltage

Overview

The A422A is a charge sensitive preamplifier, designed to be used with semiconductor detectors and in particular whenever the charge division is required (as in position sensitive silicon detectors). The unit accepts both positive and negative input pulses. A Test input for detector gain calibration and a HV input (up to 5 kV) for the detector bias are also included. The output is an inverting unipolar voltage pulse, proportional in amplitude to the integrated charge; decay time is 300 μ s. A Timing output provides an unipolar inverting fast voltage pulse, with a 15 ns typical rise time, across a 50 Ω load. Three different sensitivities (5, 30 or 60 mV/MeV) can be selected.

Ordering Option

Code	Description
WA422AXAAAA	A422A - Charge Sensitive Preamplifier with timing (Box)

A1422H

Low Noise Fast Rise Time Charge Sensitive Preamplifiers (Hybrid)

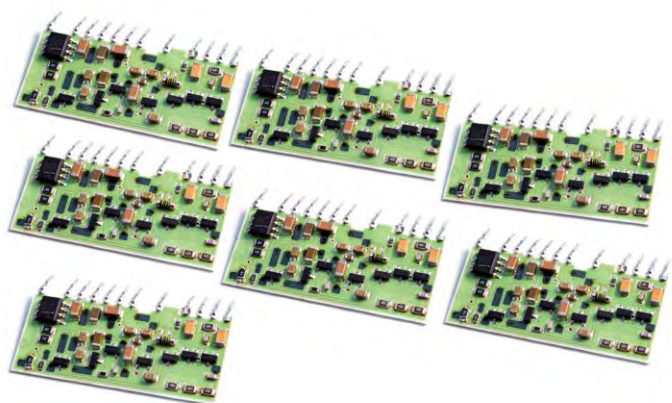

Features

- Fast, low noise inverting preamplifier
- Positive or negative input signals
- Four available sensitivities (Si equivalent): 5, 45, 90 and 400 mV/MeV
- Up to 1000 pF detector capacitance supported
- Up to 200 V (positive or negative) detector bias voltage

Overview

The A1422H series are charge sensitive preamplifiers. Various sensitivities (5 mV/MeV, 45 mV/MeV, 90 mV/MeV and 400 mV/MeV) are available and various detectors capacitances (up to 200 pF and 1000 pF so far) are supported. All of them can be used in nuclear and subnuclear physics experiments, where very low noise, fast response and high counting rates are required. The modules accept both positive and negative charge pulses and provide an energy output in the ± 3.5 V range across a 50 Ω load. Moreover, a test input accepts positive and negative signals for calibration purposes.

The preamplifiers are designed with the Cold Discharge Mechanism: this allows to have a low decay time value maintaining a very high feed-resistance value.

This technique provides good performances minimizing the pile-up in presence of moderate high counting rates.

Due to the low power consumption, the preamplifier can operate also in a vacuum chamber without the use of cooling systems.

Ordering Option

Detector capacitance pF	Gain mV/MeV	Ordering Code	Description
200	5	WA1422H005F2	A1422H005F2 - Hybrid Charge Preamplifier, 5mV/MeV gain, Cdet<200pF
	45	WA1422H045F2	A1422H045F2 - Hybrid Charge Preamplifier, 45mV/MeV gain, Cdet<200pF
	90	WA1422H090F2	A1422H090F2 - Hybrid Charge Preamplifier, 90mV/MeV gain, Cdet<200pF
	400	WA1422H400F2	A1422H400F2 - Hybrid Charge Preamplifier, 400mV/MeV gain, Cdet<200pF
1000	5	WA1422H005F3	A1422H005F3 - Hybrid Charge Preamplifier, 5mV/MeV gain, Cdet<1000pF
	45	WA1422H045F3	A1422H045F3 - Hybrid Charge Preamplifier, 45mV/MeV gain, Cdet<1000pF
	90	WA1422H090F3	A1422H090F3 - Hybrid Charge Preamplifier, 90mV/MeV gain, Cdet<1000pF

Charge Sensitive Preamplifiers

A1422

Low Noise Fast Rise Time Charge Sensitive Preamplifiers

Overview

The A1422 series are charge sensitive preamplifiers packaged in a 1/4/8 channels box. Various sensitivity values are available and various detectors capacitances are supported:

F2 type: up to 200 pF; sensitivity: 5, 45, 90, 400 mV/MeV (Si equivalent)

F3 type: up to 1000 pF; sensitivity: 5, 45, 90 mV/MeV (Si equivalent)

All of them can be used in nuclear and subnuclear physics experiments, where very low noise, fast response and high counting rates are required. The modules accept both positive and negative input charge pulses and provide an energy output of ± 3.5 V range on 50 Ω termination (± 8 V on 1 k Ω). Moreover, a test input accepts positive and negative signals for calibration purposes.

The Preamplifiers are available also as 15 pin single-in-line packaged hybrid (see Mod. A1422H).

The preamplifiers are designed with the Cold Discharge Mechanism: this allows to have a low decay time value maintaining a very high feed-resistance value. This technique provides good performances minimizing the pile-up in presence of moderate high counting rates.

The A1422 are implemented into alloy boxes and feature SHV connectors for the IN/DETECTOR and HV BIAS signals, LEMO connectors for the TEST IN and ENERGY OUT and a cable with a D-type 9 pin male connector for the power supply.



Features

- Fast, low noise inverting preamplifier
- Four available sensitivities (Si equivalent):
 - 5 mV/MeV
 - 45 mV/MeV
 - 90 mV/MeV
 - 400 mV/MeV
- Up to 1000 pF detector capacitance supported
- 1, 4 and 8 channel model available
- Up to 2 kV (positive or negative) detector bias voltage

Detector capacitance pF	Gain mV/MeV	No. of Channels	Ordering Code	Description
200	5	1	WA1422A005F2	A1422A005F2 - 1Ch. Charge Preamplifier, 5mV/MeV gain, Cdet<200pF
		4	WA1422B005F2	A1422B005F2 - 4Ch. Charge Preamplifier, 5mV/MeV gain, Cdet<200pF
		8	WA1422C005F2	A1422C005F2 - 8Ch. Charge Preamplifier, 5mV/MeV gain, Cdet<200pF
	45	1	WA1422A045F2	A1422A045F2 - 1Ch. Charge Preamplifier, 45mV/MeV gain, Cdet<200pF
		4	WA1422B045F2	A1422B045F2 - 4Ch. Charge Preamplifier, 45mV/MeV gain, Cdet<200pF
		8	WA1422C045F2	A1422C045F2 - 8Ch. Charge Preamplifier, 45mV/MeV gain, Cdet<200pF
	90	1	WA1422A090F2	A1422A090F2 - 1Ch. Charge Preamplifier, 90mV/MeV gain, Cdet<200pF
		4	WA1422B090F2	A1422B090F2 - 4Ch. Charge Preamplifier, 90mV/MeV gain, Cdet<200pF
		8	WA1422C090F2	A1422C090F2 - 8Ch. Charge Preamplifier, 90mV/MeV gain, Cdet<200pF
	400	1	WA1422A400F2	A1422A400F2 - 1Ch. Charge Preamplifier, 400mV/MeV gain, cdet<200pF
		4	WA1422B400F2	A1422B400F2 - 4Ch. Charge Preamplifier, 400mV/MeV gain, Cdet<200pF
	1000	5	1	WA1422A005F3
4			WA1422B005F3	A1422B005F3 - 4Ch. Charge Preamplifier, 5mV/MeV gain, Cdet<1000pF
8			WA1422C005F3	A1422C005F3 - 8Ch. Charge Preamplifier, 5mV/MeV gain, Cdet<1000pF
45		1	WA1422A045F3	A1422A045F3 - 1Ch. Charge Preamplifier, 45mV/MeV gain, Cdet<1000pF
		4	WA1422B045F3	A1422B045F3 - 4Ch. Charge Preamplifier, 45mV/MeV gain, Cdet<1000pF
		8	WA1422C045F3	A1422C045F3 - 8Ch. Charge Preamplifier, 45mV/MeV gain, Cdet<1000pF
90		1	WA1422A090F3	A1422A090F3 - 1Ch. Charge Preamplifier, 90mV/MeV gain, Cdet<1000pF
		4	WA1422B090F3	A1422B090F3 - 4Ch. Charge Preamplifier, 90mV/MeV gain, Cdet<1000pF
		8	WA1422C090F3	A1422C090F3 - 8Ch. Charge Preamplifier, 90mV/MeV gain, Cdet<1000pF

Charge Sensitive Preamplifiers

A1424

Scintillation Preamplifier



Features

- Fast, low noise inverting preamplifier specifically designed for Scintillation Detectors
- Variable sensitivity from 0.8 to 10 mV/pC
- Fast output for timing measurements
- Test input for calibration

Overview

The A1424 is a preamplifier designed for Scintillation Detectors widely used in Nuclear and High Energy Physics where low noise, fast response and high counting rates are required.

The A1424 relies on an inverting Charge Sensitive Preamplifier which integrates both positive and negative input charge pulses coming from the Photodetector (e.g. PMT) coupled to the Scintillator. It provides a voltage signal in the ± 4 V range on 50Ω termination (± 8 V on $1 \text{ k}\Omega$) with exponential decay ($\tau = 50 \mu\text{s}$) as Energy output. The height of the resulting pulse is proportional to the integrated charge. The sensitivity of the Charge Sensitive Preamplifier can be set via a 10 position rotary switch ranging from 0.8 to 10 mV/pC.

The A1424 is provided with a non-inverting buffer (gain ≈ 1), which reproduces the input signals coming from the detector as Fast output being useful for timing measurements. Moreover, a test input accepts positive and negative signals for calibration purposes.

Ordering Option

Code	Description
WA1424XAAAAA	A1424 - Scintillation Preamplifier

Fast Preamplifiers

NEW

A1425 Fast Charge Preamplifier



Features

- Fast, inverting preamplifier
- Sensitivity of 3.6 mV/fC
- ENC of 0.21 fC (1300 e)
- Input impedance 200Ω
- Output impedance of 50Ω
- Output range 0 to 1 V
- Up to 1 kV (positive or negative) detector bias voltage

Overview

The A1425 is a fast and low noise preamplifier with AC coupled input. The fast rise time makes it suited for amplifying the signals from detectors as fast silicon sensors and diamond detectors. It has been designed for spectroscopical applications, and can be combined with sub-nanosecond measurements of particle time-of flight. It is optimized for high-speed single MIP particle detection with diamond detectors, where the signal integrated charge is extremely small. It integrates a high voltage input for detector bias up to 1 kV.

Ordering Option

Code	Description
WA1425XAAAAA	A1425 - Fast Charge Preamplifier NEW

A1426 CARDARELLI

Matched Preamplifier

COMING
SOON

Overview

The A1426 is a fast and low noise preamplifier with AC coupled input. It is composed by two amplification stages implementing BJT NPN silicon technology. The amplifier A1426 has been designed to be used with fast detectors as e.g. the diamond detectors and the resistive plate chambers. It is suited for detectors installed in hostile environments with high radiation flux and high temperature, when is not possible to connect the front-end electronics in proximity of the sensor (in reactors or in beams of high intensity and high ionizing particles). The amplifier can be connected to the detector with a coaxial cable without significant degradation of its performance. In embed a high voltage input for detector bias rated up to 1 kV.

Based on the fast preamplifier developed by R. Cardarelli, INFN Roma2



Features

- Fast, non-inverting preamplifier, positive output
- Sensitivity of 5 mV/fC
- ENC of 0.11 fC (700 e)
- Input impedance of 50 Ω
- Output range 0 to 1 V
- Output impedance of 50 Ω
- Up to 1 kV (positive or negative) detector bias voltage

Ordering Option

Code	Description	
WA1426XAAAA	A1426 CARDARELLI - Matched Preamplifier	COMING SOON

Overview

The A1423B is an inverting Wideband Amplifier designed for fast detectors, as SiPMs and Diamonds, having a bandwidth of ~ 1.5 GHz (-3 dB). The gain ranges from $+18$ dB to $+54$ dB and it is locally controlled through a rotary switch. The amplifier accepts both positive and negative input pulses and can provide an energy output in the ± 1 V range across a 50 Ω load.

The amplifier is AC decoupled with an input and output impedance of 50 Ω (SWR $< 1.5:1$) and can carry a bias voltage for the detector up to ± 750 V. The A1423B is implemented in a shielded box and features SMA connectors for the HV BIAS, IN/DETECTOR and OUTPUT. The input circuit includes a protection network to prevent damage to the input circuit from transient generated in the IN/HV network (up to ± 500 V).

Ordering Option

Code	Description
WA1423XBAAAA	A1423B - Wide Band Preamplifier

A1423B

Wideband Amplifier



Features

- Bandwidth: ~ 1.5 GHz (-3 dB)
- Positive or negative input signals
- Gain range: from $+18$ dB to $+54$ dB
- Output voltage: ± 1 V
- Input and output impedance 50 Ω , SWR $< 1.5:1$
- Noise Figure: 7 dB @ 1 GHz
- Up to 750 V (positive or negative) detector bias voltage

N5424

Quad NIM Power distributor

Overview

The CAEN N5424 is a 4-channel NIM power distribution and control module.

The individual Voltage outputs (± 6 V, ± 12 V and ± 24 V) are protected by electronic fuses which automatically recover after short circuit. All six voltages are surveyed for each of the four outputs. The status is displayed by LEDs. The module also helps to check the correct voltage levels of a NIM-bin. If a NIM-bin without ± 24 V is used, the corresponding LEDs get off, and the voltage survey of those voltages is skipped.

Low-noise preamplifiers require DC power that is free of interference generated by other modules inserted in the bin. The mod. N5424 ensures this low-noise capability by filtering the power lines separately at each connector.

Ordering Option

Code	Description
WN5424XAAAA	N5424 - Quad NIM Power Distributor for A1422 Preamplifier

Features

- Single-width NIM module
- Four DB9 connectors with ± 6 V, ± 12 V, ± 24 V each
- Survey of all 6 voltages on each output
- Protection of all voltages by self-recovering electronical fuses
- Individually filtered outputs to ensure low noise operation
- Standard voltage output compatible to CAEN electronics and to many other manufacturers

**Features**

- Four DB9 connectors to supply A1422 family and A1424 preamplifiers
- One plug connector to supply DT57xx family desktop digitizers
- Four DB9 connectors with ± 12 V each

Overview

The DT5423 is a desktop power supply for A1422 and A1424 preamplifiers and DT57xx Digitizers family. It provides four standard 9-pin "D-type" female connectors to supply up to four A1422 or A1424 preamplifiers. Each output is filtered and fuse protected.

DT5423

Quad Desktop Power distributor

**Ordering Option**

Code	Description
WDT5423XAAAA	DT5423 - Desktop Power Supply for A1422-A1424 Amplifiers & DT57xx Digitizers

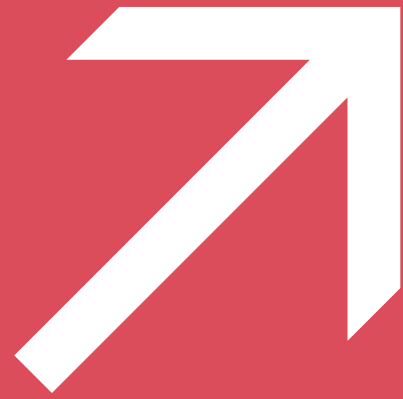

Powered crates are mandatory to make VME and NIM modules properly work, providing the power needed by the electronics, allowing the communication between the user and the boards and guaranteeing an appropriate cooling of the powered units.

CAEN offers a complete selection of VME, NIM and Mixed Powered Crates with different configuration of power supplies and backplanes to satisfy the needs of large installations and small laboratories.

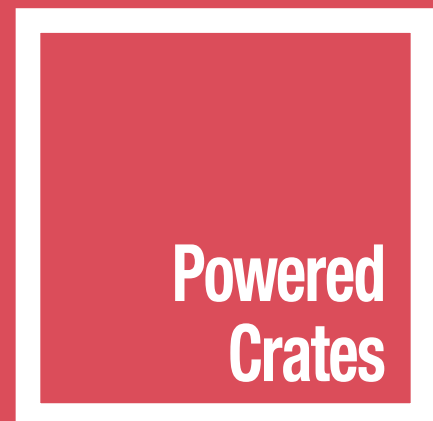

VME Powered Crates
NIM Powered Crates
Mixed Powered Crates

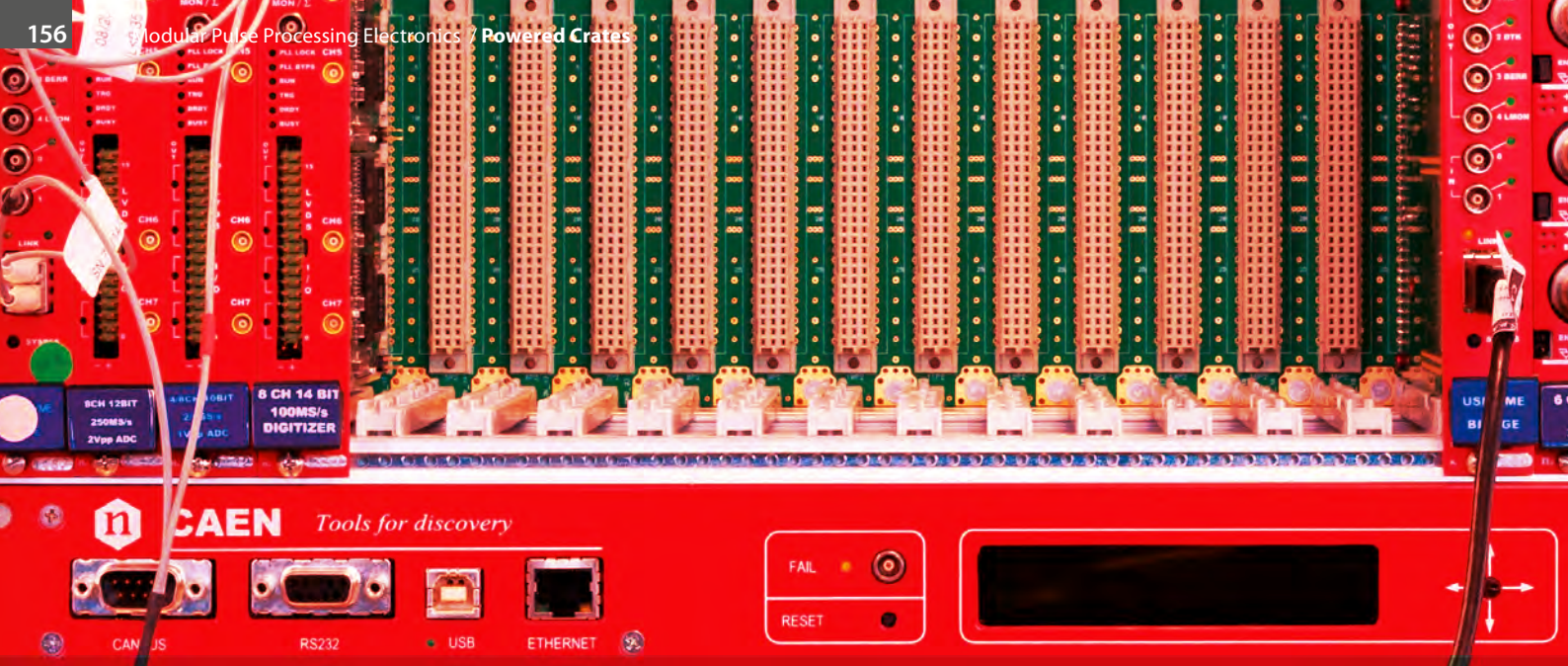

Introduction to CAEN Powered Crates

CAEN VME, NIM and Mixed Powered Crates: your modular electronics deserve only the finest accommodations!

Key Features

- Crates compliant with VME64, VME64X and NIM standards
- Several sizes tailored for all needs
- Mixed NIM/VME crate available
- Modular power supplies available in multiple configurations
- Modular Smart Fan units
- Thermal and electrical protections
- Remote connections to monitor and set the operational conditions
- VME crates with CBLT compliant automatic daisy chain



VME



NIM



MIXED

Overview

CAEN has decades of expertise in the design and production of VME and NIM powered crates. The full line of crates is intended to guarantee reliability and mechanical solidity. All CAEN VME or NIM boards can find a perfect match with our powered crates, which provide the necessary power supply, the proper air cooling and, in our top models, remote communication through the intelligent fan unit. Safety features are also implemented, as under/over voltage, short circuit and over temperature protections.

CAEN offers a selection of VME, NIM and Mixed Powered Crates with different configurations of power supplies and backplanes. Some crates can be ventilated with pluggable fan units, which also allow to have

additional interfaces for remote monitoring and setting via CAN bus, Ethernet, USB and RS232.

Our customers can choose between several configurations able to meet the needs of complex applications and small setups. Many possible choices of crate formats and power supply units are available. The latter ones are designed to guarantee extreme low voltage ripple, in particular the linear power supplies for NIM crates, which are commonly used in applications where extreme low noise is demanding. The VME crates are equipped with backplanes compliant with the standards VME64 J1/J2, VME64X J1/J2 and VME64X J1/J0/J2, supporting the automatic daisy chain compliant with CBLT.



Automatic Daisy Chain capability supports IACKIN/IACKOUT and CBLT

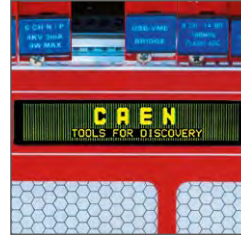

OLED Display guarantees optimal visibility in all environmental condition



Modularity and multiple power supply configurations

VME Powered Crates Family - Table comparing models

Model	Package	No. of Slots	Width	Height	Backplane connectors	Pluggable power supplies	Pluggable fan unit	Remote control	Max. Output power
VME8001	VME64	2 (6U)	19"	1U	VME64 J1/J2	No	No	No	170 W
VME8004B	VME64	4 (6U)	19"	2U	VME64 J1/J2	No	No	No	365 W
VME8004X	VME64X	4 (6U)	19"	2U	VME64X J1/J0/J2	No	No	No	450 W
VME8008X	VME64X	8 (6U)	19"	4U	VME64X J1/J0/J2	No	No	No	450 W
VME8008B	VME64	8 (6U)	19"	4U	VME64 J1/J2	No	No	No	490 W
VME8010	VME64	21 (6U)	19"	7U	VME64 J1/J2	No	No	No	470 W
VME8011	VME64	21 (6U)	19"	7U	VME64 J1/J2	Yes	No	No	470 W
VME8100	VME64 VME64X	21 (6U)	19"	8U	VME64 J1/J2 VME64X J1/J2 VME64X J1/J0/J2	Yes	Yes	RS232, USB (2.0), CANBUS, Ethernet	1200 W @ 100 Vac 2530 W @ 211 Vac
VME8200	VME64X	21 (6U) 21 Rear	19"	9U (8U + 1U Air Filter)	VME64X J1/J0/J2	Yes	Yes	RS232, USB (2.0), CANBUS, Ethernet	1200 W @ 100 Vac 2530 W @ 211 Vac

NIM & Mixed Powered Crates Family - Table comparing models

Model	Package	No. of Slots	Width	Height	Backplane connectors	Pluggable power supplies	Pluggable fan unit	Remote control	Max. Output power
NIM8301	NIM	12	19"	7U	NIM	Yes	Yes	RS232, USB (2.0), CANBUS, Ethernet	300 W / 600 W
NIM8302	NIM short size	10	19"	5U	NIM	Yes	No fan unit	No	150 W
NIM8303	NIM	12	19"	5U	NIM	Yes	No fan unit	No	300 W / 600 W
NIM8304	NIM	12	19"	7U	NIM	Yes	Yes	RS232, USB (2.0), CANBUS, Ethernet	1100 W @ 110 Vac 2200 W @ 220 Vac
NIM8305	NIM	2	170 mm	124 mm	NIM	No	No	No	430 W
NIM8306	NIM	2	170 mm	124 mm	NIM	No	No	No	720 W
NV8020A	NIM/VME64	NIM: 5 VME: 8	19"	7U	NIM/ VME64 J1/J2	NIM: Yes VME: No	No	No	NIM: 150 W VME: 365 W



VME8100

8U 21 Slot VME64/64X Enhanced Crate Series



Software Tools
available Free!

Overview

The VME8100 crates are based on a modularity concept and consist of three easy-to-exchange parts:

- The Subrack: 6U bin with 21 slot monolithic backplane (VME64 or VME64X)
- Pluggable power supply: available in different configurations providing up to 2500 W to the backplane
- Smart Fan Unit: 2U fan tray with OLED display, local controls and CAN bus, Ethernet, USB, RS232 interfaces for remote access to the crate

Safety features include: short circuit, over/undervoltage and over temperature protections.

Monitor and setting of the operational parameters are managed by a SBC controlled either locally thanks to a 4-directional switch and graphic OLED display or remotely via CAN bus, Ethernet, USB and RS232.

The VME backplane supports CBLT compliant automatic daisy chain.

User friendly control software completes the VME8100 features.

The crate is powered by 92 ÷ 264 Vac, 50 ÷ 60 Hz, power factor 0.98% (230 Vac).

An optional SNMP (Simple Network Management Protocol) agent is also available for the remote control of VME8100. SNMPv2 and SNMPv3 are supported.

Great performances, low ripple, customizable power, full set of local and remote controls, outstanding connectivity make this crate our top of the line!

Features

- 19" x 8U (6+2) enclosure
- 21 slot for 6U x 160 mm VME modules
- Available with VME64, VME64X compliant monolithic backplane
- Pluggable power supplies with different configurations up to 2500 W
- Pluggable 2U Smart Fan Unit
- Short circuit protection
- Over / Undervoltage protection
- Over temperature protection
- CAN bus, Ethernet, USB, RS232 interfaces for remote monitoring and control
- SBC controlled with graphic OLED display
- Automatic daisy chain, CBLT compliant
- Easy firmware upgrading
- Libraries, demos (C and LabVIEW) and software tools for Windows and Linux
- SNMP support available



The 2U Smart Fan Unit shows a 4-directional switch, OLED display and various interfaces (CAN bus, Ethernet, USB, RS232) for local and remote control of the crate.



The user can easily monitor all the operational parameters as supply voltages, fan speed and temperature.

Technical Specifications

Mechanics	8U bin for 6U x 160 mm VME cards, 21 slots, 2U space for fan tray		
Backplane	VME64 J1/J2, VME64X J1/J2 - J1/J0/J2 Automatic daisy chain, CBLT compliant		
Mains Input	Auto range: 92 ÷ 264 Vac, 50 ÷ 60 Hz, inrush current: <16 A @ 230 Vac power. fact. > 0.98 @ Output Power > 1 kW		
Fuse	External 16 A, type B/C		
Maximum Output Power	1200 W @ 100 Vac 2530 W @ 211 Vac		
Power Requirements	1760 W @ 100 Vac at full load 3600 W @ 211 Vac at full load		
Maximum Currents	110/220 A @ +5 V 20/40 A @ +/-12 V 110/220 A @ +3.3 V		
Isolation	CE acc. to EN 61010		
Load Regulation	< 10 mV for 0-100% load change @ +5 V < 10 mV for 0-100% load change @ +3.3 V < 15 mV for 0-100% load change @ +/-12 V		
Efficiency	75% ÷ 85% @ 230 Vac configuration dependent		
Noise and Ripple	Measured at output connector	+5 V < 10 mVpp, < 2 mVrms Typ: 6.0 mVpp, 1.5 mVrms +3.3 V < 10 mVpp, < 2 mVrms Typ: 6.0 mVpp, 1.5 mVrms +/-12 V < 10 mVpp, < 2 mVrms Typ: 4.5 mVpp, 1.0 mVrms	Measured at load (0.5 m wire) +5 V < 5 mVpp, < 1.5 mVrms Typ: 2.5 mVpp, 0.5 mVrms +3.3 V < 5 mVpp, < 1.5 mVrms Typ: 2.5 mVpp, 0.5 mVrms +/-12 V < 10 mVpp, < 1.5 mVrms Typ: 5.5 mVpp, 0.5 mVrms
Temperature Sensors	Power Supply Control: nr. 1 FAN Unit: nr. 1 Backplane: nr. 8 (optional)		
Over Voltage Protection	Trip Off when the output voltage > 103% ÷ 120% (programmable) of set voltage		
Under Voltage Protection	Trip Off when the output voltage < 80% ÷ 97% (programmable) of set voltage		
Over Current Protection	Trip Off when the current > programmable Iset value		
Over Temperature Protection	Trip Off when temperature of a single Power Supply block > 90° C Signaled: - temperature FAN Unit > 50° C - temperature Power Supply Control > 65° C		
Operation	0 ÷ 50° C without derating		
Cooling Airflow	540 m³/h (at maximum fan speed)		
Interface	RS 232, USB (2.0), CAN bus, Ethernet		
Firmware	VME8100 firmware can be upgraded via Ethernet		

Ordering Options - VME8100

Backplane	Description	Ordering Code	Maximum currents			
			+5V	+12V	-12V	+3.3V
VME64 J1/J2	8U VME64 21 slot crate, J1/J2, smart fan unit	WV8100VME000	110 A	20 A	20 A	-
		WV8100VME002	110 A	40 A	40 A	-
		WV8100VME001	220 A	20 A	20 A	-
		WV8100VME003	220 A	40 A	40 A	-
VME64X J1/J2	8U VME64X 21 slot crate, J1/J2, smart fan unit	WV8100VME004	110 A	20 A	20 A	110 A
		WV8100VME006	110 A	20 A	20 A	220 A
		WV8100VME008	110 A	40 A	40 A	110 A
		WV8100VME005	220 A	20 A	20 A	110 A
		WV8100VME010	110 A	40 A	40 A	220 A
		WV8100VME007	220 A	20 A	20 A	220 A
		WV8100VME009	220 A	40 A	40 A	110 A
VME64X J1/J0/J2	8U VME64X 21 slot crate, J1/J0/J2, smart fan unit	WV8100VME011	110 A	20 A	20 A	110 A
		WV8100VME013	110 A	20 A	20 A	220 A
		WV8100VME015	110 A	40 A	40 A	110 A
		WV8100VME012	220 A	20 A	20 A	110 A
		WV8100VME017	110 A	40 A	40 A	220 A
		WV8100VME014	220 A	20 A	20 A	220 A
WV8100VME016	220 A	40 A	40 A	110 A		

Customizations - VME8100

Code	Description
WPERS0820001	Customization - SNMP for VME8100 and VME8200 families



VME8200

9U 21 Slot VME64X Enhanced Crate Series



Software Tools
available Free!

Overview

The VME8200 crates are based on a modularity concept and consist of four detachable parts:

- The Subrack: 6U bin with 21 slot monolithic backplane (VME64X J1/J0/J2). Rear side transition card cage able to house up to 21 3U or 6U x 80 mm Rear Transition Modules (RTM)
- Pluggable power supply: available in different configurations providing up to 2500 W to the backplane
- Smart Fan Unit: 2U fan tray with OLED display, local controls and CAN bus, Ethernet, USB, RS232 interfaces for remote access to the crate
- Removable 1U air filter

The power supply is placed under the VME bin, behind the Smart Fan Unit, in order to keep the rear side of the VME backplane completely accessible.

Safety features include: short circuit, over/undervoltage and over temperature protections.

Monitor and setting of the operational parameters are managed by a SBC controlled either locally thanks to a 4-directional switch and graphic OLED display or remotely via CAN bus, Ethernet, USB and RS232.

The VME64X backplane supports a CBLT compliant automatic daisy chain.

User friendly control software completes the VME 8200 features.

The crate is powered by 92 ÷ 264 Vac, 50 ÷ 60 Hz, power factor 0.98% (230 Vac).

An optional SNMP (Simple Network Management Protocol) agent is also available for the remote control of VME8200. SNMPv2 and SNMPv3 are supported.

Get the advantage of a full accessible backplane for Real Transition Modules

Features

- 19" x 9U (6+3) enclosure
- 21 slot for 6U x 160 mm VME modules
- VME64X compliant monolithic backplane
- Pluggable power supplies with different configurations up to 2500 W
- Pluggable 2U Smart Fan Unit
- Pluggable 1U air filter
- Full access to the rear side of VME backplane with rear side card cage for 3U/6U x 80mm transition modules
- Short circuit protection
- Over / Undervoltage protection
- Over temperature protection
- CAN bus, Ethernet, USB, RS232 interface for remote monitoring and control
- SBC controlled with graphic OLED display
- Automatic daisy chain, CBLT compliant
- Easy firmware upgrading
- Libraries, demos (C and LabVIEW) and software tools for Windows and Linux
- SNMP support available



VME8200 shows a full accessible rear side of its VME64X backplane and a full sized rear side card cage for 3U/6U x 80mm transition modules.



VME8200 is provided with a 1U, removable air filter to safely cool down the VME modules operating within the crate.



The 2U Smart Fan Unit shows a 4-directional switch, OLED display and various interfaces (CAN bus, Ethernet, USB, RS232) for local and remote control of the crate.

The user can easily monitor all the operational parameters as supply voltages, fan speed and temperature.

Technical Specifications

Mechanics	9U bin for 6U x 160 mm VME cards, 21 slots, 2U space for fan tray, 1U Air Filter overall dimensions: height 399.2 mm, width 482.4 mm (19"), depth 544.4 mm Rear J2/J0 area of the VME backplane available for 21 6U x 80 mm (or 3U x 80 mm) rear transition modules (RTM)		
Backplane	VME64X J1/J0/J2 Automatic daisy chain, CBLT compliant		
Mains Input	Auto range: 92 ÷ 264 Vac, 50 ÷ 60 Hz inrush current: < 16 A @ 230 Vac power. fact. > 0.98 @ Output Power > 1 kW		
Fuse	External 16 A, type B/C		
Maximum Output Power	1200 W @ 100 Vac 2530 W @ 211 Vac		
Power Requirements	1760 W @ 100 Vac at full load 3600 W @ 211 Vac at full load		
Maximum Currents	110/220 A @ +5 V 20/40 A @ +/-12 V 110/220 A @ +3.3 V		
Isolation	CE acc. to EN 60950		
Load Regulation	< 10 mV for 0-100% load change @ +5 V < 10 mV for 0-100% load change @ +3.3 V < 15 mV for 0-100% load change @ +/-12 V		
Efficiency	75% ÷ 85% @ 230 Vac configuration dependent		
Noise and Ripple	Measured at output connector	+5 V < 10 mVpp, < 2 mVrms Typ: 6.0 mVpp, 1.5 mVrms +3.3 V < 10 mVpp, < 2 mVrms Typ: 6.0 mVpp, 1.5 mVrms +/-12 V < 10 mVpp, < 2 mVrms Typ: 4.5 mVpp, 1.0 mVrms	Measured at load (0.5 m wire) +5 V < 5 mVpp, < 1.5 mVrms Typ: 2.5 mVpp, 0.5 mVrms +3.3 V < 5 mVpp, < 1.5 mVrms Typ: 2.5 mVpp, 0.5 mVrms +/-12 V < 10 mVpp, < 1.5 mVrms Typ: 5.5 mVpp, 0.5 mVrms
Temperature Sensors	Power Supply Control: nr. 1 FAN Unit: nr. 1 Backplane: nr. 8 (optional)		
Over Voltage Protection	Trip Off when the output voltage > 103% ÷ 120% (programmable) of set voltage		
Under Voltage Protection	Trip Off when the output voltage < 80% ÷ 97% (programmable) of set voltage		
Over Current Protection	Trip Off when the current > programmable Iset value		
Over Temperature Protection	Trip Off when temperature of a single Power Supply block > 90° C Signaled: - temperature FAN Unit > 50° C - temperature Power Supply Control > 65° C		
Operation	0 ÷ 50° C without derating		
Cooling Airflow	540 m³/h (at maximum fan speed)		
Interface	RS 232, USB (2.0), CAN bus, Ethernet		
Firmware	VME8200 firmware can be upgraded via Ethernet		

Ordering Options - VME8200

Backplane	Description	Ordering Code	Maximum currents			
			+5V	+12V	-12V	+3.3V
VME64X J1/J0/J2	VME64X 9U, 21 Slot J1/J10/J2, smart fan unit, RTM	WV8200VME011	110 A	20 A	20 A	110 A
		WV8200VME012	220 A	20 A	20 A	110 A
		WV8200VME013	110 A	20 A	20 A	220 A
		WV8200VME014	220 A	20 A	20 A	220 A
		WV8200VME015	110 A	40 A	40 A	110 A
		WV8200VME016	220 A	40 A	40 A	110 A
		WV8200VME017	110 A	40 A	40 A	220 A

Customizations - VME8200

Code	Description
WPERS0820001	Customization - SNMP for VME8100 and VME8200 families



VME8010 - VME8011

7U 21 Slot VME64 Low Cost Crates

Overview

The VME8010 and VME8011 are 21 slot VME crates, suitable for 6U x 160 mm boards, with VME64 compliant backplane. A 1U space is reserved for the fan tray.

The Unit is powered by 100 ÷ 240 Vac, 50 ÷ 60 Hz. The Mod. VME8011 has a pluggable Power Supply.

The power distribution is 60 A @+5 V, 6 A @-12 V, 8.9 A @+12 V.

Features

- Low cost compact solution
- 19" x 7U (6+1) enclosure
- 21 slot for 6U x 160 mm VME modules
- 470 W Power Supply
- Pluggable power supply (VME8011 only)
- VME64 J1/J2 monolithic backplane
- Short circuit protection
- Over / Undervoltage protection
- Over temperature protection
- 1U space for Fan Unit
- Powered by 100 ÷ 230 Vac, 50 ÷ 60 Hz
- CBLT cycles supported

Simple and reliable, a cost effective solution for your VME application

Technical Specifications

Mechanics	7U bin for 6U x 160 mm VME cards, 21 slots, 1U space for fan tray
Backplane	VME64 J1/J2
Mains input	Auto range: 85 ÷ 264 Vac, 47 ÷ 63 Hz inrush current: <40 A @ 264 Vac power. fact. > 0.99 Typical
Fuse	F10 A, fast type
Maximum Output Power	470 W @ 110 / 264 Vac
Power Requirements	645 W at full load
Maximum Currents	60 A @ +5 V, 6 A @ -12 V, 8.9 A @ +12 V
Isolation	CE acc. to EN 61010
Load Regulation	< 25 mV for 0-100% load change
Noise and Ripple	+5 V < 50 mV +12 V < 90 mV -12 V < 90 mV (measured at 90% of full load)
Over Current Protection	Trip off at 105-125% of the nominal values
Overvoltage Protection	Trip off at 120-130% of the nominal values
Internal Temperature Limits	Cut off: 110 °C heat sink, 70 °C ambient, autom. maximum fan speed if air above VME modules >45°C
Operation	0 ÷ 50°C without derating
Over Temperature Protection	Trip off all Output Voltages and PS internal fan
Efficiency	75% typical at 230 Vac & 100% rated power
Cooling Airflow	408 m³/h (at maximum fan speed)

Ordering Options

Code	Description
WV8010VME000(*)	8010 - 7U VME64 Low cost 21 slot crate, J1/J2
WV8011VME000	8011 - 7U VME64 Low cost 21 slot crate, J1/J2

(*) NOT Pluggable Power Supply

VME Mini Crate Series

VME8001

1U 2 Slot VME64 Mini Crate



Features

- 19" x 1U enclosure
- 2 slot for 6U x 160 mm VME modules
- 170 W Power Supply
- Short circuit protection
- Ventilation horizontal (side to side)
- VME64 J1/J2 monolithic backplane
- Powered by 100 ÷ 240 Vac, 50 ÷ 60 Hz

Overview

The VME8001 is a 2 slot VME crate, suitable for 6U x 160 mm boards, with VME64 compliant backplane. The Unit is powered by 110 ÷ 240 Vac, 50 ÷ 60 Hz. The power distribution is 16 A @ +5 V, 7 A @ +12 V, 0.7 A @ -12 V.

Note: VME8001 cooling airflow is not sufficient for CAEN Mod. V1740/VX1740, V1751/VX1751, V1730/VX1730, V1743/VX1743.

Technical Specifications

Mechanics	19"x1U enclosure, depth: 300 mm, weight: 4.1 kg; 2 slots 6U, 160 mm VME boards
Backplane	VME 2 slot monolithic backplane
Mains Input	100 ÷ 230 Vac (50 ÷ 60 Hz)
Maximum Output Power	170 W
Power Requirements	310 W
Maximum Currents	16 A @ +5 V, 7 A @ +12 V, 0.7 A @ -12 V
Noise and Ripple (backplane connector)	Typical < 20 mVpp (20 MHz bandwidth)
Isolation	CE acc. to EN 61010
Operation	0 ÷ 50°C without derating

Ordering Options

Code	Description
WV8001VME000	VME8001 - VME64 1U Mini crate, 2 Slot J1/J2, (5V 16A, +12V 7A, -12V 0.7A)

VME8004B

2U 4 Slot VME64 Mini Crate



Features

- 19" x 2U enclosure
- 4 slot for 6U x 160 mm VME modules
- 365 W Power Supply
- Short circuit protection
- VME64 J1/J2 monolithic backplane
- Horizontal Ventilation (side to side)
- Powered by 100 ÷ 240 Vac, 50 ÷ 60 Hz
- CBLT cycles supported

Overview

The Model VME8004B is a 4 slot VME crate, suitable for 6U x 160 mm boards, with VME64 compliant backplane.

The Unit is powered by 100 ÷ 240 Vac, 50 ÷ 60 Hz.

The power distribution is 25 A @ +5 V, 10 A @ +12 V, 10 A @ -12 V.

The crate provides Automatic Daisy Chain and support Chained Block Transfer (CBLT).

Technical Specifications

Mechanics	19" x 2U enclosure, depth: 290 mm, weight: 5.5 kg; 4 slots 6U, 160 mm VME boards
Backplane	VME64 J1/J2, 4 slot Automatic daisy chain
Mains Input	100 ÷ 240 Vac (50 ÷ 60 Hz)
Maximum Output Power	365 W
Power Requirements	465 W
Maximum Currents	25 A @ +5 V, 10 A @ +12 V, 10 A @ -12 V
Noise and Ripple (backplane connector)	+5 V: 10 mVpp; ±12 V: 20 mVpp Measured on 100 nF ceramic in parallel to 10 µF electrolytic
Power Supply Type	ROAL RCB600
Cooling Airflow	Horizontal Ventilation (side to side)

Ordering Options

Code	Description
WV8004BVME000	VME8004B - VME64 2U Mini crate, 4 Slot J1/J2, (5V 25A, +12V 10A, -12V 10A)

VME Mini Crate Series

NEW

VME8004X

2U 4 Slot VME64X Mini Crate



Features

- 19" x 2U enclosure
- 4 slot for 6U x 160 mm VME modules
- 450 W Power Supply
- Short circuit protection
- VME64x J1/J2/J0 monolithic backplane
- Horizontal Ventilation (side to side)
- Powered by 100 ÷ 240 Vac (50 ÷ 60 Hz)

Overview

The Model VME8004X is a 4 slot VME crate, suitable for 6U x 160 mm boards, with VME64x compliant backplane. The Unit is powered by 100 ÷ 240 Vac (50 ÷ 60 Hz). The power distribution is 25 A @ +5 V, 10 A @ +12 V, 10 A @ -12 V, 25 A @ 3.3 V. The VME8004X provides automatic daisy chain and supports CBLT data cycles.

Technical Specifications

Mechanics	19" x 2U enclosure, depth: 290 mm, weight: 5.5 kg; 4 slots 6U, 160 mm VME boards
Backplane	VME64X J0/J1/J2, 4 slot Automatic daisy chain
Mains Input	100 ÷ 240 Vac (50 ÷ 60 Hz)
Maximum Output Power	450 W
Power Requirements	565 W
Maximum Currents	25 A @ +5 V, 10 A @ +12 V, 10 A @ -12 V, 25 A @ 3.3 V
Noise and Ripple (backplane connector)	+5 V/+3.3 V: 10 mVpp; ±12 V: 20 mVpp. Measured on 100 nF ceramic in parallel to 10 µF electrolytic
Power Supply Type	ROAL RCB600
Cooling Airflow	Horizontal Ventilation (side to side)

Ordering Options

Code	Description
WV8004XVME00	VME8004X - VME64x 2U Mini crate, 4 Slot J1/J0/J2, (5V 25A, +12V 10A, -12V 10A, 3.3V 25A)

VME8008B

4U 8 Slot VME64 Mini Crate



Features

- 19" x 4U enclosure
- 8 slot for 6U x 160 mm VME modules
- 490 W Output Power
- Short circuit protection
- VME64 J1/J2 monolithic backplane
- Horizontal Ventilation (side to side)
- Powered by 100 ÷ 240 Vac (50 ÷ 60 Hz)
- CBLT cycles supported

Overview

The Model VME8008B is a 8 slot VME crate, suitable for 6U x 160 mm boards, with VME64 compliant backplane. The Unit is powered by 100 ÷ 240 Vac (50 ÷ 60 Hz). The power distribution is 50 A @ +5 V, 10 A @ +12 V, 10 A @ -12 V. The VME8008B provides Automatic daisy chain and supports Chained Block Transfer (CBLT).

Technical Specifications

Mechanics	19" x 4U enclosure, depth: 290 mm, weight: 9.5 kg; 8 slots 6U, 160 mm VME boards
Backplane	VME64 J1/J2, 8 slot Automatic daisy chain
Mains Input	100 ÷ 240 Vac (50 ÷ 60 Hz)
Maximum Output Power	490 W
Power Requirements	600 W
Maximum Currents	50 A @ +5 V, 10 A @ +12 V, 10 A @ -12 V
Noise and Ripple (backplane connector)	+5 V: 10 mVpp; ±12 V: 20 mVpp. Measured on 100 nF ceramic in parallel to 10 µF electrolytic
Power Supply Type	ROAL RCB600
Cooling Airflow	Horizontal Ventilation (side to side)

Ordering Options

Code	Description
WV8008BVME00	VME8008B - VME64 4U Mini crate, 8 Slot J1/J2, (5V 50A, +12V 10A, -12V 10A)

VME Mini Crate Series

VME8008X

4U 8 Slot VME64 Mini Crate

NEW



Features

- 19" x 4U enclosure
- 8 slot for 6U x 160 mm VME modules
- 450 W Power Supply
- Short circuit protection
- VME64X J0/J1/J2 monolithic backplane
- Horizontal Ventilation (side to side)
- Powered by 100 ÷ 240 Vac (50 ÷ 60 Hz)
- CBLT cycles supported

Overview

The Model VME8008X is a 8 slot VME crate, suitable for 6U x 160 mm boards, with VME64X compliant backplane. The Unit is powered by 100 ÷ 240 Vac (50 ÷ 60 Hz). The power distribution is 25 A @ +5 V, 10 A @ +12 V, 10 A @ -12 V, 25 A @ +3.3 V. The VME8008X provides Automatic daisy chain and supports Chained Block Transfer (CBLT).

Technical Specifications

Mechanics	19" x 4U enclosure, depth: 290 mm, weight: 9.5 kg; 8 slots 6U, 160 mm VME boards
Backplane	VME64X J0/J1/J2, 8 slot Automatic daisy chain
Mains Input	100 ÷ 240 Vac (50 ÷ 60 Hz)
Maximum Output Power	450 W
Power Requirements	565 W
Maximum Currents	25 A @ +5 V, 10 A @ +12 V, 10 A @ -12 V, 25 A @ +3.3 V
Noise and Ripple (backplane connector)	+5 V/+3.3 V: 10 mVpp; ±12 V: 20 mVpp Measured on 100 nF ceramic in parallel to 10 µF electrolytic
Power Supply Type	ROAL RCB600
Cooling Airflow	Horizontal Ventilation (side to side)

Ordering Options

Code	Description
WV8008XVME00	VME8008X - VME64x 4U Mini crate, 8 Slot J1/J0/J2, (5V 25A, +12V 10A, -12V 10A, 3.3V 25A)

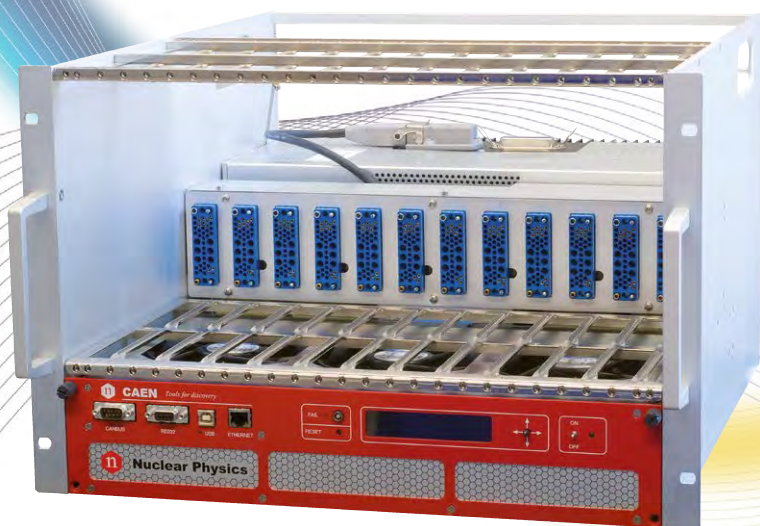

NIM8301

7U 12 Slot Smart Fan Unit 300/600 W Crate



Software Tools
available Free!

Overview

The NIM8301 is a 7U (5+2) full sized NIM crate (19"-12 slot) available with either 300 W or 600 W pluggable power supply.

The NIM modules operating within the crate are ventilated by a 2U Smart Fan Unit.

Safety features include: short circuit, over/undervoltage and over temperature protections.

Monitor and setting of the operational parameters are managed by a SBC controlled either locally thanks to a 4-directional switch and graphic OLED display or remotely via CAN bus, Ethernet, USB and RS232.

User-friendly control software completes the NIM 8301 features. The Unit is powered by 115 or 230 Vac, 50 ÷ 60 Hz.

Low Ripple Linear power supply! 300 W or 600 W, CANBUS, TCP/IP, RS232 and USB 2.0 control.

Features

- 19" x 7U (5+2) enclosure
- 12 NIM slot
- Equipped with long-life NIM connectors
- Pluggable Linear Power Supply (300 W and 600 W available)
- Pluggable 2U Fan Unit
- Short circuit protection
- Over / Undervoltage protection
- Over temperature protection
- CAN bus, Ethernet, USB and RS232 interface for remote monitoring and control
- SBC controlled with graphic OLED colour display
- Ergonomic pointer
- Libraries, Demos (C and LabVIEW) and Software tools for Windows and Linux
- Easy firmware upgrading

Ordering Options - NIM8301

Form factor	Power	Ordering Code	Maximum currents					
			+6V	-6V	+12V	-12V	+24V	-24V
7U 12 slot std size	300 W	WNIM8301300W	17 A	17 A	3.4 A	3.4 A	3.4 A	3.4 A
		WNIM8301600W	45 A	45 A	8 A	8 A	8 A	8 A
Smart Fan Unit	600 W	WNIM8301600Y	20 A	20 A	15 A	15 A	4 A	4 A
		WNIM8301600Z	45 A	45 A	18 A	18 A	-	-

Customizations

Code	Description
WPERS0833001	N8330 Customization - 110 VAC Input Adapting
WPERS0836001	N8360W Customization - 110 VAC Input Adapting

The 2U Smart Fan Unit shows a 4-directional switch, OLED display and various interfaces (CAN bus, Ethernet, USB, RS232) for local and remote control of the crate.

The user can easily monitor all the operational parameters as supply voltages, fan speed and temperature.



Technical Specifications

Mains Input	230 Vac or 115 Vac, 50 ÷ 60 Hz.			
Mechanics	19" x 7U (5+2) bin, 12 slot, 2U space for fan tray			
Maximum Output Power	300 / 600 W			
Interface	RS 232, USB (2.0), CAN bus, Ethernet			
Fuse	4 A Class T @ 300 W 220 Vac, 8 A Class T @ 300 W 115 Vac, 6.3 A Class T @ 600 W 220 Vac, 15 A Class T @ 600 W 115 Vac			
Maximum Currents	300 W			600 W
	17 A @ ±6 V 3.4 A @ ±12 V 3.4 A @ ±24 V	45 A @ ±6 V 8 A @ ±12 V 8 A @ ±24 V	20 A @ ±6 V 15 A @ ±12 V 4 A @ ±24 V	45 A @ ±6 V 18 A @ ±12 V ±24 V not present
Output Current Characteristic	Foldback (I _{sc} < 5 A I _{max} = Inominal +15%):	Foldback (I _{sc} < 15 A I _{max} = Inominal +15%):	Foldback (I _{sc} < 10 A I _{max} = Inominal +15%):	Foldback (I _{sc} < 15 A I _{max} = Inominal +15%):
Isolation	CE acc. to EN 61010			
Power Requirements	610 W and 1150 W (for 300 W and 600 W) at full load			
Noise and Ripple	< 3 mVpp @ ±6 V, ±12 V, ±24 V (Typ.) < 5 mVpp @ ±6 V, ±12 V, ±24 V (Max.)			
Output Impedance	0.3 mΩ static			
Status Control	Alarm signalled by FAIL LED, FAIL signal and buzzer Alarm reason displayed on FAN unit OLED display and managed by remote control			
Temperature Sensors	Power Supply: nr. 4 @ 300W nr. 2 @ 600W FAN Unit: nr. 2 Backplane: nr. 6 (optional)			
Output Voltage Characteristic	dual tracking for all ±DC outputs Soft start; DC output calibration (manually)			
Over Voltage Protection	Trip Off when the output voltage > 110% of nominal voltage			
Under Voltage Protection	Trip Off when the output voltage < 90% of nominal voltage			
Over Current Protection	Trip Off when the current > programmable I _{set} value			
Over Temperature Protection	Trip Off when temperature of heat sink > 70° C or when transformer temperature > 110° C Signaled: - temperature FAN Unit > 50° C - temperature Power Supply Control > 65° C			
Cooling Airflow	540 m³/h (at maximum fan speed)			
Operation	0 ÷ 40° C without derating			
Firmware	NIM8301 firmware can be upgraded via Ethernet			

NIM8303

5U 12 Slot 300/600 W Crate

Overview

The CAEN Mod. NIM8303 is a 5U non ventilated NIM crate (19"-12 slot) available with both pluggable 300 W and 600 W power supplies.

Safety features include: short circuit protection, over / undervoltage protection, over temperature protection.

The Unit is powered by 115 or 230 Vac, 50 ÷ 60 Hz.

The Mod NIM8303 is equipped with a Control panel with mains switch, status LEDs, FAIL output (LEMO 00) and test pin for all DC voltages.

Features

- 19" x 5U enclosure
- 12 slot non-ventilated NIM bin
- Pluggable Linear Power Supply (300 W and 600 W available)
- Equipped with long-life NIM connectors
- Short circuit protection
- Over / Undervoltage protection
- Over temperature protection
- Control panel with mains switch, control LEDs and LEDs / test pins for all outputs
- Optional 1U rack mountable fan unit

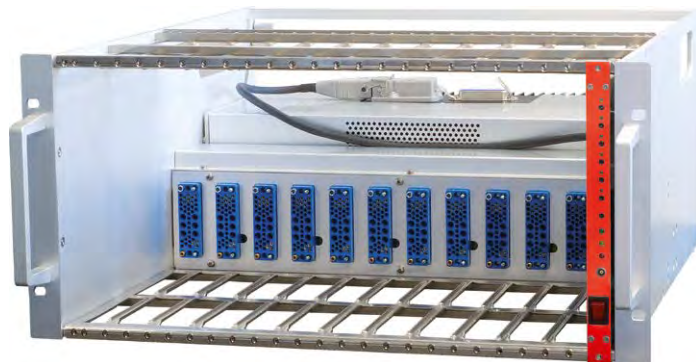

Optional A83xx 1U fan tray available to properly ventilate the NIM modules operating within the crate

Ordering Options - NIM8303

Form factor	Power	Ordering Code	Maximum currents					
			+6V	-6V	+12V	-12V	+24V	-24V
5U 12 slot std size	300 W	WNIM8303300W	17 A	17 A	3.4 A	3.4 A	3.4 A	3.4 A
		WNIM8303600W	45 A	45 A	8 A	8 A	8 A	8 A
	600 W	WNIM8303600Y	20 A	20 A	15 A	15 A	4 A	4 A
		WNIM8303600Z	45 A	45 A	18 A	18 A	-	-

Customizations

Code	Description
WPERS0833001	N8330 Customization - 110 VAC Input Adapting
WPERS0836001	N8360W Customization - 110 VAC Input Adapting

Technical Specifications

Mains input	230 Vac or 115 Vac, 50 ÷ 60 Hz.			
Mechanics	19" x 5U bin, 12 slot, non ventilated			
Maximum Output Power	300 / 600 W			
Fuse	4 A Class T @ 300 W 220 Vac, 8 A Class T @ 300 W 115 Vac, 6.3 A Class T @ 600 W 220 Vac, 15 A Class T @ 600 W 115 Vac			
Maximum Currents	300 W		600 W	
	17 A @ ±6 V	45 A @ ±6 V	20 A @ ±6 V	45 A @ ±6 V
	3.4 A @ ±12 V	8 A @ ±12 V	15 A @ ±12 V	18 A @ ±12 V
	3.4 A @ ±24 V	8 A @ ±24 V	4 A @ ±24 V	±24 V not present
Output Current Characteristic	Foldback (Isc < 5 A I _{max} = Inominal +15%):	Foldback (Isc < 15 A I _{max} = Inominal +15%):	Foldback (Isc < 10 A I _{max} = Inominal +15%):	Foldback (Isc < 15 A I _{max} = Inominal +15%):
Isolation	CE acc. to EN 61010			
Power Requirements	610 W and 1150 W (for 300 W and 600 W) at full load			
Noise and Ripple	< 3 mVpp @ ±6 V, ±12 V, ±24 V (Typ.) < 5 mVpp @ ±6 V, ±12 V, ±24 V (Max.)			
Output Impedance	0.3 mΩ static			
Status Control	±6 V, ±12 V, ±24 V LED and test point; GND test point ALARM signal, STATUS, OVERHEAT and OVERTEMPERATURE LED			
Temperature Sensors	Power Supply: nr. 4 @ 300W nr. 2 @ 600W			
Output Voltage Characteristic	dual tracking for all ±DC outputs Soft start; DC output calibration (manually)			
Over Voltage Protection	Trip Off when the output voltage > 110% of nominal voltage			
Under Voltage Protection	Trip Off when the output voltage < 90% of nominal voltage			
Over Current Protection	Trip Off when the current > programmable I _{set} value			
Over Temperature Protection	Trip Off when temperature of heat sink > 70° C or when transformer temperature > 110° C			
Operation	0 ÷ 40°C without derating			

NIM8302

5U 10 Slot 150 W Compact Crate

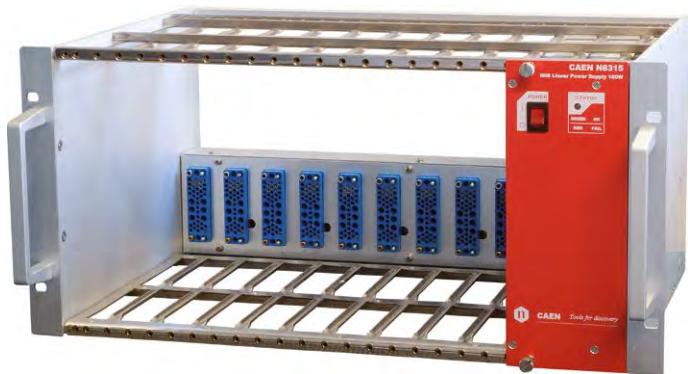

Optional A83xx 1U fan tray available to properly ventilate the NIM modules operating within the crate

Overview

The CAEN Mod. NIM8302 is a compact (10 slot free) non ventilated 5U NIM crate (19" - 10 free slot) provided with pluggable 150 W power supply. Safety features include: short circuit protection, over/undervoltage protection and over temperature protection. The Unit is powered by 115 or 230 Vac, 50 ÷ 60 Hz. On the front panel the status of power supply is indicated by green/red LED.

Features

- Cost effective, compact solution
- 19" x 5U enclosure
- 12 slot non-ventilated NIM bin (10 free slots)
- 2 slot, removable linear power supply (150 W)
- Equipped with long-life NIM connectors
- Short circuit protection
- Over / Undervoltage protection
- Over temperature protection
- Optional 1U rack mountable fan tray
- Available portable version 7 slot (5 free)

Technical Specifications

Mechanics	19" x 5U bin, 12 slot (10 free), non ventilated 270 mm x 5U, 7 slot (5 free), non ventilated (portable version)
Mains Input	230 Vac or 115 Vac, 50 ÷ 60 Hz.
Maximum Output Power	150 W
Power Requirements	280 W at full load
Fuse External	External 2 A, class T (230 Vac)
Maximum Currents	5 A @ ±6 V, 3 A @ ±12 V, 1.5 A @ ±24 V
Load Regulation	< 0.5 % for 10-100% load change, < 0.02 % for ±10% line change
Isolation	CE acc. to EN 61010
Ripple	±6 V < 5 mVpp, ±12 V < 8 mVpp, ±24 V < 10 mVpp
Transient Response Recovery	0.15 ms for recovery to ±1% of voltage for 10-100% load change
Output Impedance	0.6 mΩ static
Output Voltage Characteristic	Dual tracking for all ±DC outputs, Soft start, DC output calibration (manually)
Output Current Characteristic	OVC protection / Trip Off
Over Voltage Protection	Trip Off when the output voltage > 130% of nominal voltage
Under Voltage Protection	Trip Off when the output voltage < 70% of nominal voltage
Over Current Protection	Trip Off when current: > 6 A @ +24 V, > 2 A @ -24 V, > 6 A @ +12 V, > 3.75 A @ -12 V, > 10 A @ ±6 V
Over Temperature Protection	Trip Off when temperature > 75° C
Temperature Sensors	nr.1
Status Control	Fail/Status LED signal
Operation	0 ÷ 45°C without derating



NIM8302P/15

A portable 7 slot (5 free) also available

Ordering Options - NIM8302

Code	Description
WNIM8302150W	NIM8302/15 - NIM 5U Compact crate, 10 slot, 150W (±6V 5A, ±12V 3A, ±24V 1.5A)
WN8315WAAAAA	N8315 - NIM Linear Power supply 150W (±6V 5A, ±12V 3A, ±24V 1.5A)
WNIM8302P150	NIM8302P/15 - NIM Portable crate, 7 slot, 150W (±6V 5A, ±12V 3A, ±24V 1.5A)

NIM Mini Crate Series

NIM8305

2 Slot Switching 430 W Mini Crate



Overview

The CAEN Mod. NIM8305 is a 2 slot NIM crate with switching power supplies; the unit is provided with three ventilation fans.

The NIM8305 delivers 12 A @ ± 6 V and 12 A @ ± 12 V.

Safety features include: short circuit protection, over / under voltage protection, over temperature protection. The Unit is powered by 100 \div 240 Vac, 50 \div 60 Hz, power factor 0.98% (230 Vac).

Features

- Cost effective, compact solution
- 12 A @ ± 6 V and 12 A @ ± 12 V output
- 2 air cooled NIM slots
- Ideal for small experiments, laboratories and universities
- Portable: 170 x 310 x 125 mm³ (WxHxD); 5 kg weight
- Equipped with long-life NIM connectors
- Wide AC input voltage range: 100 Vac to 240 Vac
- Active PFC
- Extra low noise switching power supply
- ON/OFF switch
- Power good and stand-by leds
- Short circuit protection

Technical Specifications

Mechanics	2 NIM slots; dimensions: 124 x 170 x 310 mm ³ ; 5 kg weight
Mains Input	100 \div 240 Vac, 50 \div 60 Hz, power factor 0.98% (230 Vac)
Maximum Output Power	430 W
Power Plug	C14 IEC Fused Inlet
Maximum Currents	12 A @ ± 6 V, 12 A @ ± 12 V
Isolation	CE acc. to EN 60950
Power Requirements	565 W at full load
Load Regulation	± 50 mV - for 0-100% load change @ ± 6 V ± 100 mV - for 0-100% load change @ ± 12 V ± 150 mV - for 0-100% load change @ ± 24 V
Noise and Ripple (full load)	± 6 V: Max 5 mVpp, 1 mVrms, Typ 2.5 mVpp, 0.5 mVrms ± 12 V: Max 6 mVpp, 1.5 mVrms, Typ 3 mVpp, 1 mVrms
Operation	0 \div 50°C without derating
Cooling Airflow	3 x Sunon KDE1206PHV1 cooling fans

Ordering Options

Code	Description
WNIM8305XAAA	NIM8305 - NIM crate, 2 slot, Switching PS (± 6 V 12A, ± 12 V 12A)

NIM8306

2 Slot Switching 720 W Mini Crate



Overview

The CAEN Mod. NIM8306 is a 2 slot NIM crate with switching power supplies; the unit is provided with three ventilation fans.

The NIM8306 delivers 12 A @ ± 6 V, 12 A @ ± 12 V and 6 A @ ± 24 V.

Safety features include: short circuit protection, over / under voltage protection, over temperature protection. The Unit is powered by 100 \div 240 Vac, 50 \div 60 Hz, power factor 0.98% (230 Vac).

Features

- Cost effective, compact solution
- 12 A @ ± 6 V, 12 A @ ± 12 V and 6 A @ ± 24 V output
- 2 air cooled NIM slots
- Ideal for small experiments, laboratories and universities
- Portable: 170 x 310 x 125 mm³ (WxHxD); 5 kg weight
- Equipped with long-life NIM connectors
- Wide AC input voltage range: 100 Vac to 240 Vac
- Active PFC
- Extra low noise switching power supply
- ON/OFF switch
- Power good and stand-by leds
- Short circuit protection

Technical Specifications

Mechanics	2 NIM slots; dimensions: 124 x 170 x 310 mm ³ ; 5 kg weight
Mains input	100 \div 240 Vac, 50 \div 60 Hz, power factor 0.98% (230 Vac)
Maximum Output Power	720 W
Power Plug	C14 IEC Fused Inlet
Maximum Currents	12 A @ ± 6 V, 12 A @ ± 12 V, 6 A @ ± 24 V
Isolation	CE acc. to EN 60950
Power Requirements	950 W at full load
Load Regulation	± 50 mV - for 0-100% load change @ ± 6 V ± 100 mV - for 0-100% load change @ ± 12 V ± 150 mV - for 0-100% load change @ ± 24 V
Noise and Ripple (full load)	± 6 V: Max 5 mVpp, 1 mVrms, Typ 2.5 mVpp, 0.5 mVrms ± 12 V: Max 6 mVpp, 1.5 mVrms, Typ 3 mVpp, 1 mVrms ± 24 V: Max 5 mVpp, 1 mVrms, Typ 2.5 mVpp, 0.5 mVrms
Operation	0 \div 50°C without derating
Cooling Airflow	3 x Sunon KDE1206PHV1 cooling fans

Ordering Options

Code	Description
WNIM8306XAAA	NIM8306 - NIM crate, 2 slot, Switching PS (± 6 V 12A, ± 12 V 12A, ± 24 V 6A)

NIM8304

7U 12 Slot Smart Fan Unit Switching 2000 W Crate



Features

- 19" x 7U (5+2) enclosure
- 12 NIM slot
- Equipped with long-life NIM connectors
- Pluggable Switching Power Supply up to 2000 W
- Pluggable 2U Fan Unit
- Short circuit protection
- Over / Undervoltage protection
- Over temperature protection
- CAN bus, Ethernet, USB and RS232 interface for remote monitoring and control
- SBC controlled with graphic OLED colour display
- Ergonomic pointer
- Easy firmware upgrading
- Libraries, Demos (C and LabVIEW) and Software tools for Windows and Linux

Overview

The NIM8304 is a 7U (5+2) full size NIM crate (19"-12 slot) with pluggable low noise switching power supply able to provide up to 2000 W @ 220 Vac or 1000 W @ 110 Vac.

The NIM modules operating within the crate are ventilated by a 2U Smart Fan Unit. Safety features include: short circuit, over/undervoltage and over temperature protections.

Monitor and setting of the operational parameters are managed by a SBC controlled either locally thanks to a 4-directional switch and graphic OLED display or remotely via CAN bus, Ethernet, USB and RS232.

User-friendly control software completes the NIM8304 features. The unit is powered by 92 ÷ 264 Vac, 50 ÷ 60 Hz, power factor 0.98% (230 Vac).



The 2U Smart Fan Unit shows a 4-directional switch, OLED display and various interfaces (CAN bus, Ethernet, USB, RS232) for local and remote control of the crate.

The user can easily monitor all the operational parameters as supply voltages, fan speed and temperature.

Ordering Options

Code	Description
WNIM8304XAAA	NIM8304 - NIM 7U crate, 12 slot, smart fan unit, 1000W US - 2000W EU (±6V 90A, ±12V 20A, ±24V 10A)

Technical Specifications

Mechanics	19" x 7U (5+2) bin, 12 slot, 2U space for fan tray		
Mains Input	92 ÷ 264 Vac, 50 ÷ 60 Hz, power. fact. > 0.98 % (230 VAC)		
Fuse	External 16 A, type B/C		
Maximum Output Power	1100 W @ 100 Vac 2200 W @ 211 Vac		
Power Requirements	1450 W @ 100 Vac 2850 W @ 211 Vac		
Maximum Currents	EU	90 A @ ±6 V 23 A @ ±12 V 11 A @ ±24 V	US 45 A @ ±6 V 11.5 A @ ±12 V 5.5 A @ ±24 V
Isolation	CE acc. to EN 61010		
Load Regulation	< 10 mV for 0-100% load change @ ±6 V < 10 mV for 0-100% load change @ ±12 V < 15 mV for 0-100% load change @ ±24 V		
Efficiency	75% ÷ 85% @ 230 Vac configuration dependent		
Noise and Ripple	±6 V < 10 mVpp, < 2 mVrms Typ: 6.0 mVpp, 1.5 mVrms ±12 V < 15 mVpp, < 2 mVrms Typ: 10 mVpp, 1.0 mVrms ±24 V < 15 mVpp, < 2 mVrms Typ: 10 mVpp, 1.0 mVrms		
Temperature Sensors	Power Supply Control: nr. 1 FAN Unit: nr. 1 Backplane: nr. 6 (optional)		
Over Voltage Protection	Trip Off when the output voltage > 103% ÷ 120% (programmable) of set voltage		
Under Voltage Protection	Trip Off when the output voltage < 80% ÷ 97% (programmable) of set voltage		
Over Current Protection	Trip Off when the current > programmable Iset value		
Over Temperature Protection	Trip Off when temperature of a single Power Supply block > 90° C Signaled: - temperature FAN Unit > 50°C - temperature Power Supply Control > 65° C		
Operation	0 ÷ 50°C without derating		
Cooling Airflow	540 m³/h (at maximum fan speed)		
Interface	RS 232, USB (2.0), CAN bus, Ethernet		
Firmware	NIM8304 firmware can be upgraded via Ethernet		

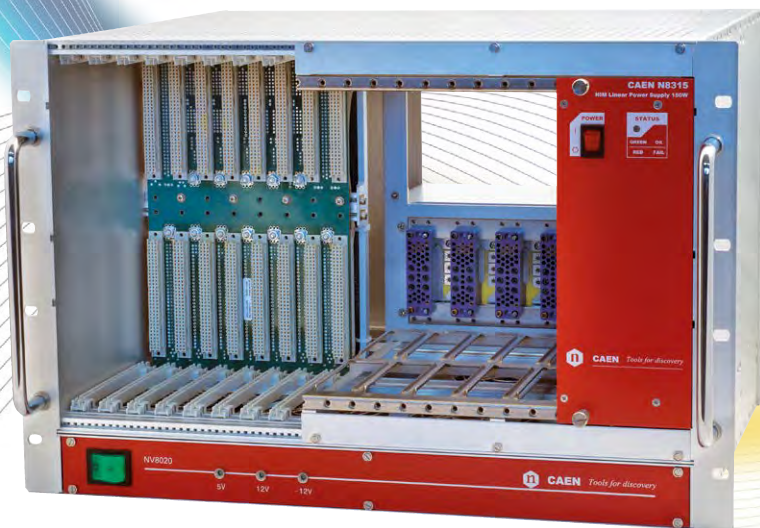

NV8020A

7U Crate VME/NIM 8 Slot VME64 365 W, 5 Slot NIM 150 W

Overview

The NV8020A is a 19" x 7U 84TE mixed VME / NIM crate equipped with a 1U common fan unit.

The VME section features 8 slots suitable for 6Ux160 mm boards, with VME64 compliant backplane. The section is powered by universal AC input Power Supply. The Power distribution is 25 A @ +5 V, 10 A @ -12 V, 10 A @ +12 V.

The NIM section consists of 7 NIM slots (5 free) provided with provided with 2.5U NIM slot linear power supply (150 W).

The Unit is powered by 110 or 220 Vac, 50 ÷ 60 Hz. On the front panel the status of power supply is indicated by green/red LED.

Two crates in 19": VME and NIM have never been so close!

Features

- 19" x 7U (6+1) enclosure mixed VME/NIM crate
- VME section:
 - 8 slot for 6U x 160 mm VME modules
 - 365 W Power Supply
 - Low noise Power Supply
 - VME64 J1/J2 monolithic backplane
- NIM section:
 - 7 slot NIM (5 free slots)
 - 2 slot linear power supply (150 W)
- 1U space for Fan Unit
- Short circuit protection
- Over / Undervoltage protection
- Over temperature protection

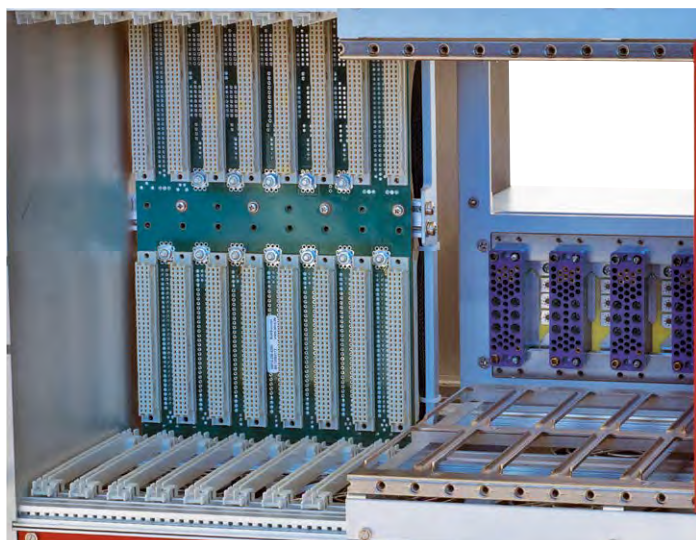

NV8020A shows two independent sections in the same chassis: a 8 slot VME64 backplane and 5 free NIM slots.

This unit is therefore a perfect solution to mix boards of the two different standards in a single front end and data acquisition system.

Technical Specifications

Mechanics	19" x 7U 84TE mixed crate VME64 (8 slots for 6U x 160 mm boards) / NIM (5 free slots) 1U common fan unit; weight: 28 kg	
Section	VME64	NIM
Backplane	J1/J2 Automatic daisy chain, CBLT compliant	Equipped with long-life NIM connectors
Mains Input	100 ÷ 240 Vac, 50 ÷ 60 Hz	230 or 115 Vac, 50 ÷ 60 Hz
Maximum Output Power	365 W	160 W
Power Requirements	475 W at full load	280 W at full load
Fuse	1 External 3.15 A, type B/C	1 External 2 A, class T (230 Vac)
Maximum Currents	25 A @ +5 V 10 A @ -12 V 10 A @ +12 V	5 A @ ±6 V 3 A @ ±12 V 1.5 A @ ±24 V
Isolation	CE acc. to EN 60950	CE acc. to EN 61010
Load Regulation	< 1 % for 0-100% load change @ +5 V < 1 % for 0-100% load change @ ±12 V	< 0.5 % for 10-100% load change < 0.02 % for ±10% line change
Noise and Ripple (backplane connector)	+5 V < 10 mVpp ±12 V < 20 mVpp	±6 V < 5 mVpp ±12 V < 8 mVpp ±24 V < 10 mVpp
Power Supply Type	ROAL RCB600 power supplies	CAEN Mod. N8315

Maximum currents								
Form factor	Mechanics	Backplane	+6 V	-6 V	+12 V	-12 V	+24 V	-24 V
NIM	NIM (5 free slots)	Equipped with long-life NIM connectors	5 A	5 A	3 A	3 A	1.5 A	1.5 A
Form factor	Mechanics	Backplane	+5 V	+12 V	-12 V	-	-	-
VME	VME64 (8 slots for 6Ux160mm boards)	VME64: J1/J2 Automatic daisy chain, CBLT compliant	25 A	10 A	10 A			

Ordering Options

Code	Description
WN8020AXAAAA	NV8020A - VME/NIM 7U crate, 8 slot VME64 365W, 5 slot NIM 150W
WN8315WAAAAA	N8315 - NIM Linear Power supply 150W (±6V 5A, ±12V 3A, ±24V 1.5A)
WVN7U6S5SXAA	VMENIM7U - Crate VME/NIM, VME64, 6 Slot VME, 5 Slot NIM

Crate Accessories

NIM8315 - A83xx

N8315

NIM Linear Power Supply 150W



Features

- Slot linear power supply (150 W)
- 2.5 NIM slot width
- Short circuit protection
- Over / Under voltage protection
- Over temperature protection
- Frontpanel with status LED and mains switch

Overview

The N8315 is a 150 W NIM Linear Power supply, suitable to any NIM crate. Safety features include: short circuit protection, over/undervoltage protection, over temperature protection. The Unit is powered by 115 or 230 Vac, 50 ÷ 60 Hz. On the front panel the status of the power supply is indicated by green/red LED.

Ordering Options

Code	Description
WN8315WAAAAA	N8315 - NIM Linear Power supply 150W ($\pm 6V$ 5A, $\pm 12V$ 3A, $\pm 24V$ 1.5A)

A83xx

General Purpose 1U Fan Unit

NEW



Features

- 19"/1U rack mountable fan tray
- 3 ventilation fans
- 450 m³/h air flow
- 47 dB noise

Overview

Thanks to three ventilation fans able to provide a 450 m³/h air flow, it is a suitable yet cost effective solution to properly ventilate NIM modules operating in those NIM bins that are not provided with a fan tray.

The unit is powered by 110 or 230 V 50 ÷ 60 Hz AC (50 W).

Ordering Options

Code	Description
WA83XXFANXAA	General Purpose 1U Fan Unit 220Vac
WA83XXFANXAB	General Purpose 1U Fan Unit 110Vac



DIGITAL SPECTROSCOPY

Our cutting edge technology for everyday need of laboratory analysis, security and environmental monitoring

In the last decade CAEN developed a wide offer of digital data acquisition instrumentation able to meet different nuclear spectroscopy requirements in a flexible way. This is the result of years of experience collected by collaborating in research projects which requested the design of electronics for innovative radiation detection. The present section introduces the recent series of instruments dedicated to the fields of Environmental Monitoring, Homeland Security and Cultural Heritage Preservation. These instruments are the synthesis of CAEN acknowledged design capabilities: high performance Waveform Digitizers with Digital Pulse Processing and state-of-the-art High Voltage Power Supplies, giving rise to a powerful yet compact family of products.

This section contains the description of high performance digital Multichannel Analyzers for high resolution semiconductor detectors. Moreover portable MCA for outdoor operation with scintillator detectors and pulse shape discriminators for gamma neutron discrimination.

- **Dual & Quad Digital Multichannel Analyzers**
- **Compact Digital Multichannel Analyzers**
- **Dual Digital Pulse Analyzers**
- **Stand-Alone MCA Tube base**



FORM FACTOR



DESKTOP

INTERFACES

USB Ethernet

COMING
SOON

HEXAGON

Dual Digital Multichannel Analyzer

The first CAEN fully standalone Dual Digital MCA

Features

- Dual 32k Digital MCA featuring Digital Pulse Processing
- Provides pulse height analysis (PHA), time-stamped list mode and multichannel scaler (MCS coming soon)
- Dedicated to high resolution gamma ray spectroscopy, suited for HPGe detectors and for scintillation detectors as NaI and LaBr₃.
- Designed to operate with continuous and transistor reset preamplifiers
- Two HV power supply channels (up to 5 kV) with HV inhibit (BNC), programmable ramp and accurate parameter monitoring
- Two DB9 connectors for preamplifier power supply (± 12 V, ± 24 V), HV inhibit and TEMP read
- Two BNC inputs for TRP inhibit or ADC gate
- Configurable coincidence or anti-coincidence of signals among the two analog inputs and external logic inputs
- Open access to embedded CPU for custom developments
- LCD Display on the front panel for system status monitoring
- Software programmable coarse and fine gain
- Online pile-up rejection and dead time calculation
- Digital oscilloscope function for diagnostic purposes
- Suited for high count rate applications
- Link for synchronizing multiple MCAs
- Programmable digital I/Os (e.g. ICR, SCA, MCS start/stop, MCS advance and sweep, etc...)
- Analog monitor output (signal scope)
- USB and Ethernet communication interfaces
- Drivers, libraries and API for Windows and Linux 32/64-bit
- MC²Analyzer software to manage the acquisition and to perform basic spectrum analysis

Overview

Hexagon is a compact, stand-alone dual digital 32k MCA, available in desktop form factor. It is designed for high energy resolution semiconductor detectors, like HPGe and Silicon Drift Detectors, connected to Charge Sensitive Preamplifiers.

Hexagon integrates advanced firmware algorithms operating Digital Pulse Processing for Pulse Height Analysis (PHA). The embedded CPU runs an OS able to execute custom routines for automated operations. The processing algorithms can be easily adapted to different detectors and application ensuring effective data analysis even at high count rates. It provides advanced tools for configuring baseline restoration and pile-up rejection. Moreover the module features on-board spectrum recording, acquisition settings logging and autonomous data acquisition when unconnected from external devices. Thanks to the two input simultaneous acquisition, the module is able to manage coincidence and anti-coincidence logic between detectors, allowing the user, for example, to easily take advantage of background rejection or anti-Compton techniques.

Hexagon embeds I/O connectors for SCA, MCS and Coincidence/Anticoincidence functions, it integrates High Voltage Inhibit and TRP Inhibit. Clock and Synchronization connectors are provided, which allow the time stamp of multiple modules to be aligned with high accuracy. The module embeds an LCD screen to monitor real time the data acquisition results, e.g. ICR, OCR and dead time. Hexagon may provide at the same time energy, time stamp and the digitized pulse in a configurable time window (e.g. including the rising edge region) in order to perform further offline analysis. Acquisition settings and mathematical analysis are performed through the MC²Analyzer software, providing energy spectra with up to 32k channels, which can be exported and imported in ASCII or N42.42 compliant files. CAEN further provides drivers for the supported communication interfaces; configuration software tools, C and LabVIEW libraries (CAENComm, CAENDigitizer, CAENDPP), demo applications and utilities.

The two high voltage supply channels can be ordered in three different polarity configurations: both channel positive, both channels negative and mixed.

Software



Digital Spectroscopy

FORM FACTOR



NIM DESKTOP

INTERFACES

USB Optical Link



780 MCA Family Dual Digital Multichannel Analyzer

Overview

The 780 MCA family is composed by compact, stand-alone dual digital 16k MCA with integrated HV & Preamplifier Power Supply, available in desktop and NIM form factors.

They are designed for high energy resolution semiconductor detectors, like HPGe and Silicon detectors with resistive feedback Charge Sensitive Preamplifiers.

The 780 MCA family integrates advanced firmware algorithms operating Digital Pulse Processing for Pulse Height Analysis (PHA). The processing algorithms can be easily adapted to different detectors and application ensuring effective data analysis even at high count rates. It provides advanced tools for configuring baseline restoration, pile-up rejection. Thanks to the two input simultaneous acquisition, the modules are able to manage coincidence and anti-coincidence logic between detectors, allowing the user, for example, to easily take advantage of background rejection or anti-Compton techniques.

These MCAs may provide at the same time energy, time stamp and the digitized pulse in a configurable time window (e.g. including the rising edge region) in order to perform further offline analysis. Acquisition settings and mathematical analysis are performed through the MC²Analyzer software, providing energy spectra with up to 16k channels, which can be exported and imported in ASCII or N42.42 compliant files. CAEN further provides drivers for the supported communication interfaces; configuration software tools, C and LabVIEW libraries (CAENComm, CAENDigitizer, CAENDPP), demo applications and utilities.

The high voltage supply channel can be ordered in three different versions to meet detector requirements: rated up to ± 5 kV/300 μ A for high purity germanium detectors, ± 4 kV/3 mA (limited to 4 W) for scintillation detectors and ± 500 V/3 mA for silicon and diamond detectors.

A complete, compact solution for gamma spectroscopy

Features

- Dual independent 16k Digital MCA available in desktop and NIM form factors
- Dedicated to high resolution gamma ray spectroscopy with HPGe detectors
- Two HV power supply outputs and HV inhibit inputs for detector safety
- Two DB9 connectors for preamplifier power supply
- Digital oscilloscope function for an easy setup and signal monitoring
- Software adjustable coarse and fine gain
- Features Digital Pulse Processing for PHA, providing energy and time stamp in list mode
- Software adjustable digital shaping filter, baseline restoration
- On-line pile-up rejection and software dead time evaluation
- Suited for high count rate applications
- Configurable coincidence or anti-coincidence of signals in the two analog inputs
- USB 2.0 and Optical Link communication interfaces
- Drivers, libraries and API for Windows and Linux 32/64-bit
- MC²Analyzer software to manage the acquisition and to perform basic spectrum analysis

Software



Ordering Options

Code	Description	Form Factor
WDT5780XMAAA	DT5780M - Dual Digital MCA - 1 HVPS +5kV/300uA, 1 HVPS -5kV/300uA, 2 LVPS ±12V/100mA, ±24V/50mA	Desktop
WDT5780XNAAA	DT5780N - Dual Digital MCA - 2 HVPS -5kV/300uA, 2 LVPS ±12V/100mA, ±24V/50mA	Desktop
WDT5780XPAAA	DT5780P - Dual Digital MCA - 2 HVPS +5kV/300uA, 2 LVPS ±12V/100mA, ±24V/50mA	Desktop
WDT5780SDXMA	DT5780SDM - Dual Digital MCA - 1 HVPS +500V/3mA, 1 HVPS -500V/3mA, 2 LVPS ±12V/100mA ±24V/50mA	Desktop
WDT5780SDXNA	DT5780SDN - Dual Digital MCA - 2 HVPS -500V/3mA, 2 LVPS ±12V/100mA, ±24V/50mA	Desktop
WDT5780SDXPA	DT5780SDP - Dual Digital MCA - 2 HVPS +500V/3mA, 2 LVPS ±12V/100mA, ±24V/50mA	Desktop
WDT5780SCXMA	DT5780SCM - Dual Digital MCA - 1 HVPS +4kV/3mA, 1 HVPS -4kV/3mA, 2 LVPS ±12V/100mA ±24V/50mA	Desktop
WDT5780SCXNA	DT5780SCN - Dual Digital MCA - 2 HVPS -4kV/3mA, 2 LVPS ±12V/100mA, ±24V/50mA	Desktop
WDT5780SCXPA	DT5780SCP - Dual Digital MCA - 2 HVPS +4kV/3mA, 2 LVPS ±12V/100mA, ±24V/50mA	Desktop
WN6780XMAAAA	N6780M - Dual Digital MCA - 1 HVPS +5kV/300µA, 1 HVPS -5kV/300uA, 2 LVPS ±12V/100mA, ±24V/50mA	NIM
WN6780XNAAA	N6780N - Dual Digital MCA - 2 HVPS -5kV/300µA, 2 LVPS ±12V/100mA, ±24V/50mA	NIM
WN6780XPAAA	N6780P - Dual Digital MCA - 1 HVPS +5kV/300µA, 2 LVPS ±12V/100mA, ±24V/50mA	NIM

COMING SOON
COMING SOON
COMING SOON

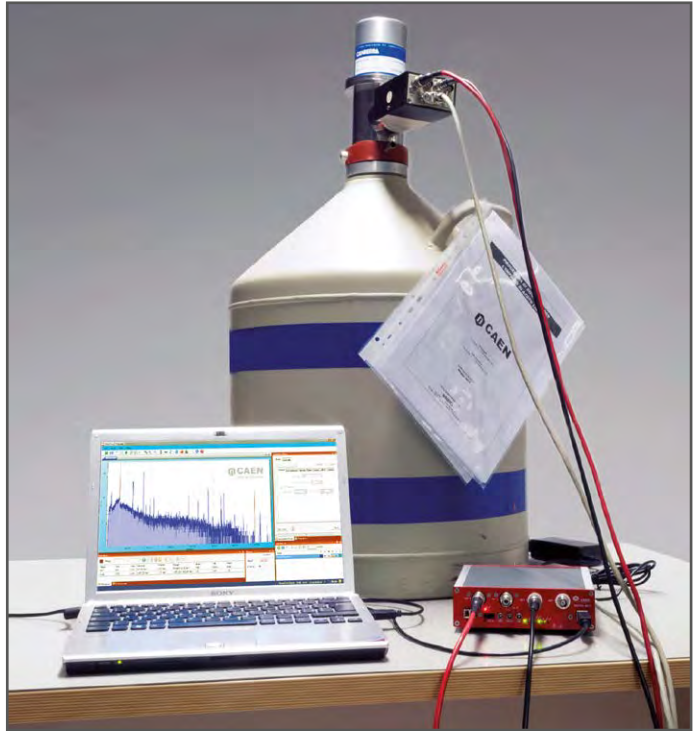

Digital Spectroscopy

FORM FACTOR



NIM DESKTOP

INTERFACES

USB Optical Link



781 MCA Family

Dual / Quad Digital Multichannel Analyzer

NEW

Overview

The 781 MCA family is composed by compact, stand-alone Dual or Quad independent 16k digital MCA, available in Desktop and NIM form factors.

They are designed for high energy resolution semiconductor detectors, like HPGe and Silicon detectors with resistive feedback Charge Sensitive Preamplifiers.

The 781 MCA family integrates advanced firmware algorithms operating Digital Pulse Processing for Pulse Height Analysis (PHA). The processing algorithms can be easily adapted to different detectors and application ensuring effective data analysis even at high count rates. It provides advanced tools for configuring baseline restoration and pile-up rejection. Thanks to the multiple input simultaneous acquisition, the module is able to manage coincidence and anti-coincidence logic between detectors, allowing the user, for example, to easily take advantage of background rejection or anti-Compton techniques.

These MCAs can provide at the same time energy, time stamp and the digitized pulse in a configurable time window (e.g. including the rising edge region) in order to perform further offline analysis. Acquisition settings and mathematical analysis are performed through the new MC²Analyzer software, providing energy spectra with up to 16k channels, which can be exported and imported in ASCII or N42.42 compliant files. CAEN provides moreover drivers for the supported communication interfaces, configuration software tools, C and LabVIEW libraries (CAENComm, CAENDigitizer, CAENDPP), demo applications and utilities.

A compact and flexible solution for digital nuclear spectroscopy

Features

- Dual or Quad independent 16k digital MCA available in desktop and NIM form factors
- Dedicated to high resolution gamma ray spectroscopy with HPGe detectors
- Digital oscilloscope function for an easy setup and signal monitoring
- Software adjustable coarse and fine gain
- Features Digital Pulse Processing for PHA, providing energy and time stamp in list mode
- Software adjustable digital shaping filter, baseline restoration
- On-line pile-up rejection and software dead time evaluation
- Suited for high count rate applications
- Configurable coincidence or anti-coincidence of signals in the analog inputs
- USB 2.0 and Optical Link communication interfaces
- Drivers, libraries and API for Windows and Linux 32/64-bit
- MC²Analyzer software to manage the acquisition and perform basic spectrum analysis

Ordering Options

Code	Description	Form Factor
WDT5781AXAAA	DT5781A - 2 Channel Digital MCA	Desktop
WDT5781XAAAA	DT5781 - 4 Channel Digital MCA	Desktop
WN6781AXAAAA	N6781A - 2 Channels Digital MCA	NIM
WN6781XAAAAA	N6781 - 4 Channels Digital MCA	NIM

Software



FORM FACTOR



DESKTOP

INTERFACES

USB Ethernet

**NEW**

DT5770

Compact Digital Multichannel Analyzer

A pocket-size, high performance and cost-effective solution for your spectroscopy applications.

Features

- Compact portable 16k Digital MCA
- Suited for high resolution gamma spectroscopy
- Support continuous and pulsed reset preamplifiers
- Software selectable coarse and fine gain
- DB9 connector for preamplifier power supply
- Features Pulse Height Analysis firmware for energy calculation
- Different acquisition modes are available: PHA and signal inspector for an easy setup and signal monitoring
- Software adjustable digital shaping filter, baseline restoration
- On-line pile-up rejection and software dead time evaluation
- USB and Ethernet communication interfaces
- MC²Analyzer software to manage the acquisition and perform basic spectrum analysis

Overview

The DT5770 is a compact portable Digital MCA for Gamma spectroscopy.

It is suited for high energy resolution semiconductor detectors, like HPGe and Silicon Drift Detector, connected to a Charge Sensitive Preamplifier. It integrates analog front-end with programmable gain and possible AC coupling.

The DT5770 relies on a dedicated firmware for Pulse Height Analysis (PHA). The firmware performs real time Digital Pulse Processing allowing an effective data analysis even at high count rate. It provides baseline restoration, pile-up rejection, dead time and live time estimation.

The DT5770 houses USB 2.0 and Ethernet interfaces.

The DT5770 can provide at the same time energy, time stamp and the digitized pulse in a configurable time window (e.g. including the rising edge region) in order to perform further offline analysis. Acquisition settings and mathematical analysis are performed through the new MC²Analyzer software, providing energy spectra with up to 16k channels, which can be exported and imported in ASCII or N42.42 compliant files. CAEN provides moreover drivers for the supported communication interfaces, DT5770 Upgrader tool and C libraries (CAENDPP library).

Software



Ordering Options

Code	Description
WDT5770AXAAA	DT5770 - Digital MCA - 1 LVPS $\pm 12V/100mA \pm 24V/50mA$

Digital Spectroscopy

FORM FACTOR



DESKTOP

INTERFACES

USB Optical Link



DT5790

Dual Digital Pulse Shape Discriminator

Overview

The DT5790 is a digital acquisition system for scintillators and other detectors. It is ideally suited for Organic, Inorganic and Liquid Scintillators coupled to photodetectors like PMTs and SiPMs whose pulses can be directly accepted by the board.

It is a compact, stand-alone digital system that houses a two channel, 12 bit, 250 MS/s digitizer, two HV channels able to supply a bias voltage up to ± 4 kV and current up to 3 mA (4 W maximum) and two connectors to power preamplifiers.

The DT5790 relies on a dedicated firmware developed for Charge Integration and Pulse Shape Discrimination (PSD). The PSD is based on an advanced on line Digital Dual Gate Charge Integration with no conversion dead time allowing an effective data analysis even at high count rate. It performs signal baseline calculation, dual gate self-generation with programmable parameters, double integration of both prompt and total charge for Pulse Shape Discrimination and pedestal subtraction for energy calculation. Thanks to the two input simultaneous acquisition, the module is able to manage coincidence and anti-coincidence between a pair of detectors, allowing the user to easily take advantage of background rejection or anti-Compton techniques.

The DT5790 provides at the same time energy, time stamp and the digitized pulse in a configurable time window (e.g. including the rising edge region) in order to perform further offline analysis. CAEN provides moreover drivers for the supported communication interfaces, configuration software tools, C and LabVIEW libraries (CAENComm, CAENDigitizer), demo applications and utilities.

An all-in-one solution for gamma-neutron discrimination

Features

- Dual digital charge-to-digital converter based on 12-bit 250 MS/s Flash ADCs
- Dedicated to organic or inorganic scintillation detectors
- Two HV power supply outputs rated up to ± 4 kV/3 mA
- Two DB9 connectors for preamplifier power supply
- On-line digital pulse processing for charge integration and pulse shape discrimination
- No dead time due to conversion
- Digital oscilloscope function for an easy setup and signal monitoring
- Pile-up rejection
- Configurable coincidence or anti-coincidence of signals in the two analog inputs
- USB 2.0 and Optical Link communication interfaces
- Drivers, libraries and API for Windows and Linux 32/64-bit

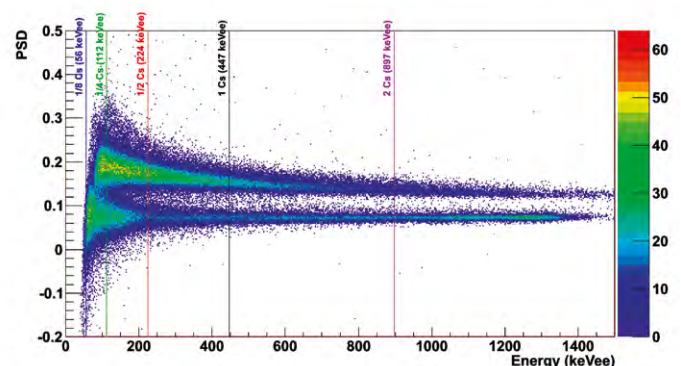

Application Notes

AN2506 Digital Gamma Neutron discrimination with Liquid Scintillators

All these documents are available for download in the Document Library section of CAEN website.

Ordering Options

Code	Description
WDT5790XMAAA	DT5790M - 2 Channel 12 bit 250Ms/digitizer with 1HV ch +4kV/3mA 1HV ch -4kV/3mA for PSD
WDT5790XNAAA	DT5790N - 2 Channel 12 bit 250Ms/digitizer with 2HV ch -4kV/3mA for PSD
WDT5790XPAAA	DT5790P - 2 Channel 12 bit 250Ms/digitizer with 2HV ch +4kV/3mA for PSD

Software



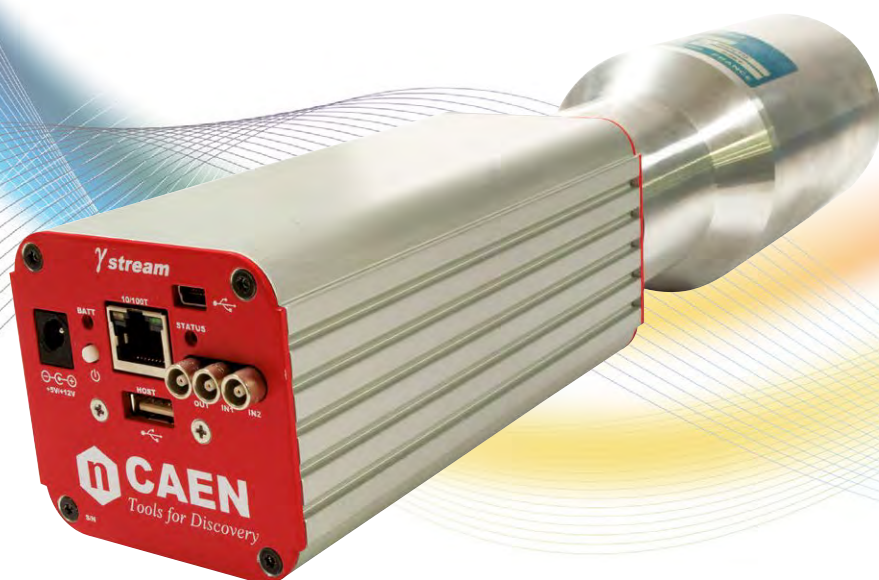

Digital Spectroscopy

FORM FACTOR



PORTABLE

INTERFACES

USB Ethernet Bluetooth Wi-Fi

NEW

Ystream

Active, stand-alone, fully featured MCA tube base for scintillation

Gamma Spectroscopy goes wireless with the innovative CAEN tube base digital MCA: Untie your detector and get on-line!

Features

- Fully stand-alone MCA including high voltage power supply, preamplifier, battery and data-storage on SSD
- Compatible with scintillation detectors as NaI(Tl), LaBr₃(Ce), and CeBr₃, using standard 14-pin and 10-8 stages PMTs
- Different acquisition modes available signal inspector, time stamped list mode, PHA, SCA (coming soon), MCS (coming soon)
- Open access to embedded CPU for custom developments
- Available with embedded GPS for data geo-localization
- Gain stabilizer based on natural or calibration radioactivity
- Wire and wireless connectivity through USB, Ethernet, Bluetooth and Wi-Fi
- Front panel cover against dust and rain for outdoor operation
- Front panel auxiliary digital I/O connectors for synchronization, external trigger, coincidence/anticoincidence modes, veto, MCS, SCA
- Supported by CAEN MC²Analyzer software GUI, and GammaTOUCH application for smartphones and tablets with Android OSs



Ystream rear view. Internal divider can be adapted for NaI(Tl), LaBr₃(Ce), CeBr₃ detectors with standard 14-pin and 10-8 stages PMTs.

Overview

Ystream is an active MCA integrated in a 14-pin PMT base for gamma-ray spectroscopy with scintillation detectors, suited for portable and mobile spectrometry. It integrates high voltage power supply, preamplifier and digital MCA. The embedded CPU runs an OS able to execute custom routines for automatic wireless spectroscopic analysis and data monitoring. Featured with battery and data-storage it is able to run without external connection or controller. The flexibility on data logging modes makes it suitable for most survey situations.

It may acquire and record data in different modes: signal inspector, time stamped list mode, PHA, SCA (coming soon) and MCS (coming soon). *Ystream* can also operate outdoor thanks to a front panel cover protecting from water and dust.

Wireless and wired connection interfaces are available: Wi-Fi, Bluetooth, USB and Ethernet. *Ystream* can also be integrated in more complex systems thanks to auxiliary I/O connectors.

Ystream is suited for a variety of environment thanks also to the software suites GammaTOUCH and MC²Analyzer, both provided with user-friendly GUIs. GammaTOUCH can run on smartphones or tablets with Android OSs, providing an immediate and easy data acquisition control. It provides georeferenced and time-stamped histograms logging the location of the integrated GPS system or the one embedded in the mobile device. On the other side MC²Analyzer can be run on recent Windows OS, providing the user with histogram analysis tools.

Software



Ordering Options

Code	Description
WS2580XAAAA	S2580 - GAMMASTREAM - Digital MCA Tube Base for Gamma-Ray Spectroscopy
WS2580LBXAAA	S2580LB - GAMMASTREAM - Digital MCA Tube Base for LaBr ₃ (Ce) Gamma-Ray Spectroscopy
WS2580GXAAAA	S2580G - GAMMASTREAM - Digital MCA Tube Base with GPS for Gamma-Ray Spectroscopy
WS2580LBGXAA	S2580LBG - GAMMASTREAM - Digital MCA Tube Base with GPS for LaBr ₃ (Ce) Gamma-Ray Spectroscopy

Digital
Spectroscopy



Free Download
Software



Software for Digital Spectroscopy

GammaTOUCH

Gamma *stream* Control Software for Android™



FREE
DOWNLOAD



Overview

GammaTOUCH is a software application for Android™ running on personal devices like smartphones or tablets, fully compatible with CAEN *stream* device. It is designed as an easy-to-use assistant for outdoor operations and provides an immediate control of *stream*. Energy spectra can be

displayed, and statistics can be monitored runtime. Through the GammaTOUCH it is possible to integrate the GPS coordinates and time of the mobile device with the time-stamped event list.



MC²Analyzer (MC²A)

Digital MCA Data Acquisition and Analysis Software



FREE
DOWNLOAD



Overview

MC²A is a software specifically designed to manage CAEN Digital MCA (780/781 family, DT5770 and *stream*) as well as CAEN digitizers running DPP-PHA (Digital Pulse Processing for the Pulse Height Analysis) firmware, like 724, 725 or 730 families.

It allows the user to set the relevant parameters, to manage the

HV channels configuration (x780 and y stream only), to collect the spectra and perform mathematical analysis, like energy calibration, peak search, background subtraction, peak fitting, etc.

It is designed for multi-channel and multi-board capabilities: it can handle several boards and manage the data acquisition from each of them at the same time.



DPP-PSD Control Software

Graphical Interface for DPP-PSD Management



FREE
DOWNLOAD



Overview

DPP-PSD Control Software is the graphical interface for managing the waveform digitizers running Pulse Shape Discrimination (DPP-PSD). It can manage single-board communication and acquisition of the DT5790 Digital Pulse Shape Discriminator and CAEN 720, 725, 730, 751 Digitizer running DPP-PSD firmware.

The user can easily set all the DPP-PSD parameters, configure the DT5790, run the acquisition, readout data and plot or save the results in form of waveforms as well as charge and time tag histograms or lists.

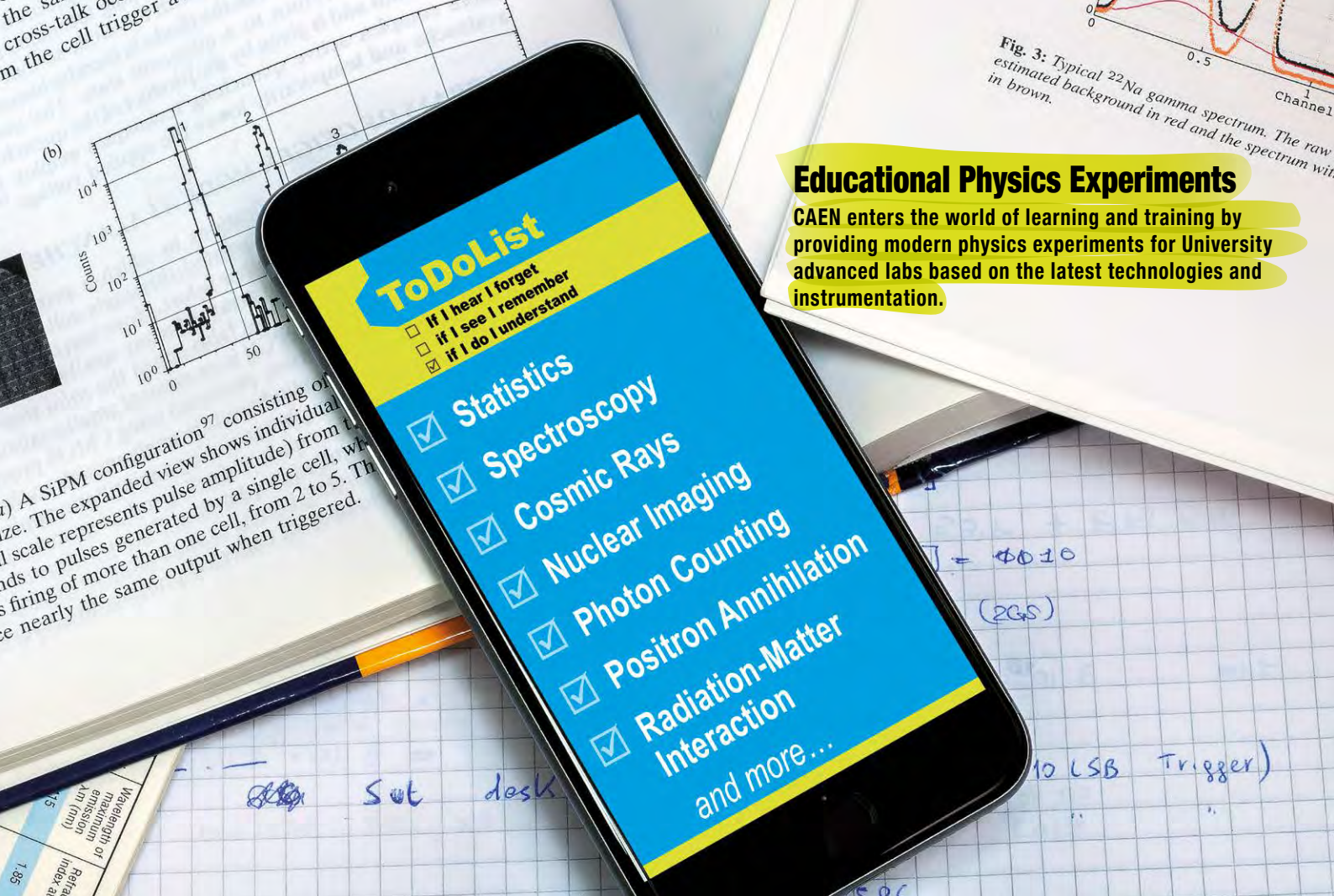

Fig. 3: Typical ^{22}Na gamma spectrum. The raw estimated background in red and the spectrum with in brown.

Educational Physics Experiments

CAEN enters the world of learning and training by providing modern physics experiments for University advanced labs based on the latest technologies and instrumentation.

ToDoList

- If I hear I forget
- If I see I remember
- If I do I understand

- Statistics
- Spectroscopy
- Cosmic Rays
- Nuclear Imaging
- Photon Counting
- Positron Annihilation
- Radiation-Matter Interaction
- and more...

(b) A SiPM configuration 97 consisting of... size. The expanded view shows individual... scale represents pulse amplitude) from... nds to pulses generated by a single cell, wh... s firing of more than one cell, from 2 to 5. Th... ce nearly the same output when triggered.

1.85	Reflex index at
	Maximum of emission
	Amplitude (mm)

CAEN EDUCATIONAL



Collaboration with University of Insubria, Como, Italy.

We proudly support the development of critical thinking

CAEN brings the experience acquired in more than 35 years of collaboration with the High Energy & Nuclear Physics community into the University educational laboratories. Thanks to the most advanced instrumentation developed by CAEN for the major experiments worldwide, together with the University teaching experience at the University of Insubria, a series of experiments covering several applications has been carried out and are presented in detailed Educational Notes.

The goal is to inspire students and guide them towards the analysis and comprehension of different physics phenomena with a series of experiments based on state-of-the art technologies, instruments and methods.



A dedicated catalog and Webpage will be available soon.

For more information: educational@caen.it



NEW

SP5600C - SP5600D - SP5600E - SP5600AN Nuclear and Modern Physics Kits



Applications

- **γ Spectroscopy:** from system linearity to radiation absorption, Photonuclear and Compton Scattering cross sections
- **β Spectroscopy:** from energy spectrum to thickness measurements
- **Cosmic rays:** from cosmic rays detection to cosmic vertical flux measurement
- **Photon detection:** light distribution and single photon detection
- **Radiation-Matter Interaction:** from scintillating materials to absorber materials comparison
- **Advanced Statistics**

Overview

CAEN realized different modular Educational Kits. The set-up are all based on Silicon Photomultipliers (SiPM) state-of-the-art sensor of light with single photon sensitivity and unprecedented photon number capability.

Three Educational kits are available :

SP5600C - Educational Gamma Kit, SP5600D - Educational Beta kit and SP5600E - Educational Photon kit. A Premium version, SP5600AN, including all the components of the three kits is also available.

The kits are configured to perform several experiments, covering different Physics fields. Exploring the quantum nature of phenomena is one of the most exiting experiences a physics student can live.

What is being proposed has to do with light quanta, radioactive decays (β and γ rays) and cosmic rays. The experiments address the essence of the phenomenon as well as exemplary illustrations of their use in medical imaging and industry, complemented by basic and advanced statistical exercises.

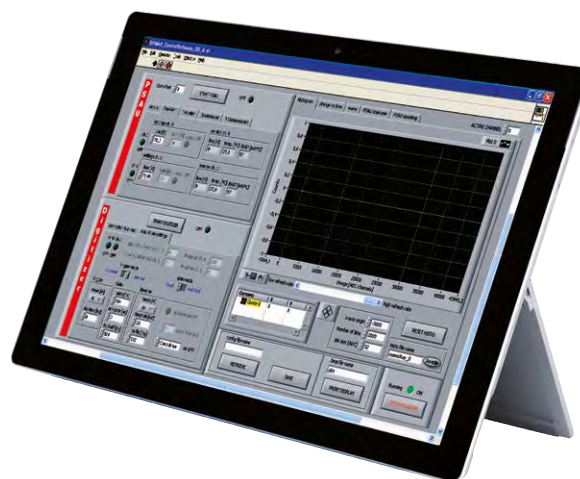
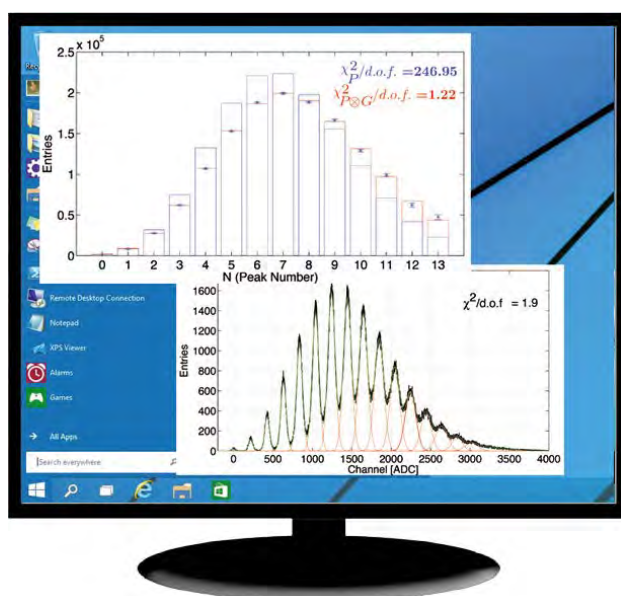

The kits are provided with a dedicated LabVIEW based Control Software and a MATLAB® based Data Analysis Software.

Code	Description
WK5600XCAA	SP5600C - Educational Gamma Kit
WK5600XDAA	SP5600D - Educational Beta Kit
WK5600XEAA	SP5600E - Educational Photon Kit
WK5600XANAA	SP5600AN - Educational Kit - Premium Version

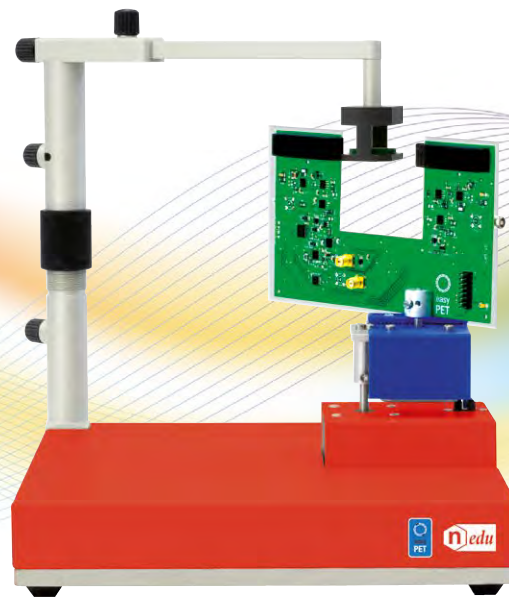

SP5700
EasyPET

**COMING
SOON**



universidade
de aveiro

Overview

The EasyPET is a user friendly and portable PET system, designed to explore the physical and technological principles of the conventional human PET scanners.

Thanks to a technology developed by University of Aveiro, the EasyPET uses only two detectors to execute a PET scan, simplifying the set-up to make it accessible to Educational Laboratories.

EasyPET is controlled through a MATLAB® graphic user interface which allows the setting of the acquisition parameters, visualizing the reconstructed image in real time during acquisition and performing several didactic experiments related to PET imaging, as well as offline image analysis.

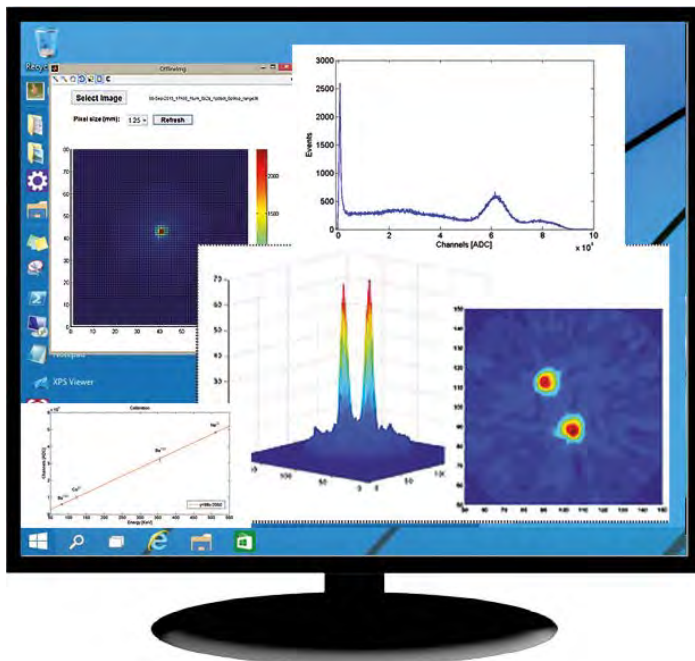

Applications

- γ Spectroscopy and System Linearity
- Positron Annihilation Detection
- Nuclear Imaging
- Two-dimensional Reconstruction of a Radioactive Source
- Source Spatial Resolution
- Efficiency measurements



Code	Description
WSP5700XAAA	SP5700 - EasyPET



NEW

SP5600EMU Emulation Kit



Features

- γ and α Spectroscopy and System Linearity
- Real Energy spectrum emulation
- Noise emulation
- Time distribution Emulation (Poissonian)
- Continuous pre-amplifier emulation
- Statistic
- No need of radioactive source

Overview

The “Emulation kit” is based on the CAEN Digital Detector-Emulator (DT4800) together with the Digital Multichannel Analyzer (DT5770). This kit allows to perform a series of lab experiments without using a radioactive source and a detector but simulating the signals produced by the interaction of particles with the detecting unit.

The core of the system is the DT4800, called Micro Digital Detector Emulator, the most compact and cost effective model of the Detector Emulators family. It is available only in a one channel version and it is particularly suited for simple emulation needs and educational purposes. The unit features one analog output and one digital input. As a Pulser it can generate exponential decay signals with programmable Rise Time and Fall Time up to a rate of 1 Mcps. The rate can be fixed or it can follow a Poissonian distribution. In Emulation mode the unit can reproduce signals from a real energy spectrum that can be uploaded in the form of CSV or ANSI N42.42 files. A database of nuclides is provided to generate specific emission lines and Gaussian noise can be added. An user friendly control software is provided with the unit.



Code

Description

WK5600XEMUAA SP5600EMU - Emulation Kit

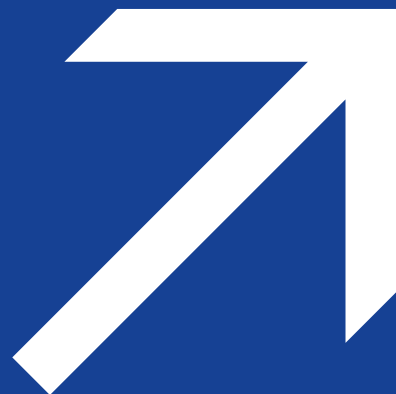

Liquid Argon TPC
Analog multiplexed ASICs
SiPM arrays

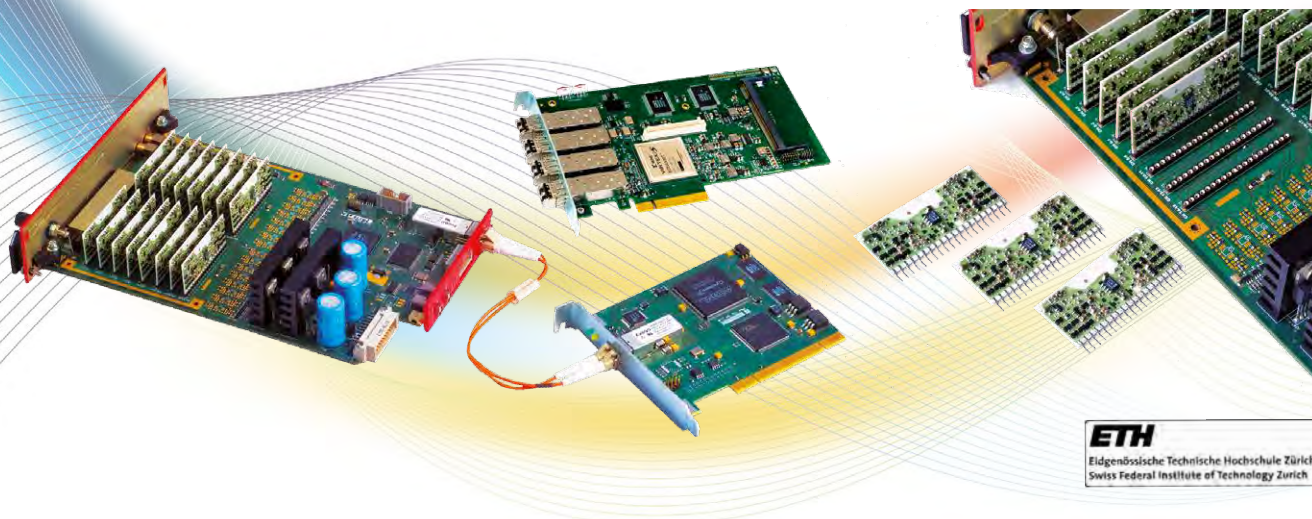

SY2791

Liquid Argon TPC Readout System

Overview

The SY2791 is a complete detector readout system, ideally suited for liquid Argon TPC (Time Projection Chamber), but easily customizable for a wide variety of detectors. The system is housed in a 19" 4U crate that contains the A2793 AC/DC power supply unit and eight A2792 acquisition modules, with 32 channels each. In total, one SY2791 can read up to 256 channels.

The analog signals coming from the detector feed directly the inputs of the A2792s, where the preamplifiers (sold separately) are arranged in arrays of plug-in hybrid circuits (2 channels each) and enclosed in a metal shielded box. This solution allows the preamplifier to be chosen to match the specific requirements. The preamplifier outputs are digitized by 12-bit 2.5MS/s flash ADCs and processed by the internal acquisition logic, implemented in a programmable FPGA, which provides the trigger logic, the data storage in local memory buffers and the readout through a proprietary optical link, controlled by the PCI board A2818.

This compact and modular solution permits to place the readout electronics very close to the detector, giving the best performances in terms of noise and resolution. The optical fiber allows the system to be connected to the host PC as far as few hundred meters; the fiber guarantees easy cabling and absence of ground loops. One PCI card A2818 can control up to eight daisy chained A2792s (that is one full crate). Typically, one PC can host four A2818s, which means 1024 channels controlled and readout from a single commercial PC.

The system has been designed for the scalability: growing from a single crate with 256 channels up to experiments with thousands of channels is made easy by the TT-Link. This is a single wire bus (over a coaxial cable) connecting as many crates as needed, that distributes the same sampling clock to all the ADCs of the whole system and the same global commands, like triggers, start/stop acquisition, reset, etc. thus keeping all the acquisition boards synchronized.

Following the preamplifier output, the system operates as a waveform digitizer: the 32 serial outputs of the ADCs are connected to one FPGA which continuously picks the

digital samples and stores them, in parallel for all the channels, into an array of circular memory buffers (Multi Event Buffer). When a channel is triggered, the FPGA keeps writing the programmable number of samples that stay within the post trigger window and then saves the current buffer (i.e. an acquisition window) of that channel; such data events are completed by a header and a time tag.

The acquisition can continue without dead-time in a new circular buffer. Channels operate independently from each other and are triggered when the relevant input signal crosses a programmable digital threshold. It is possible to propagate the trigger of one channel through the TT_Link and create channel groups in which one channel over threshold "alerts" the other ones that can decide to lower their threshold and let a very small signal trigger the acquisition. A global trigger common to all the channels can be also issued, using software



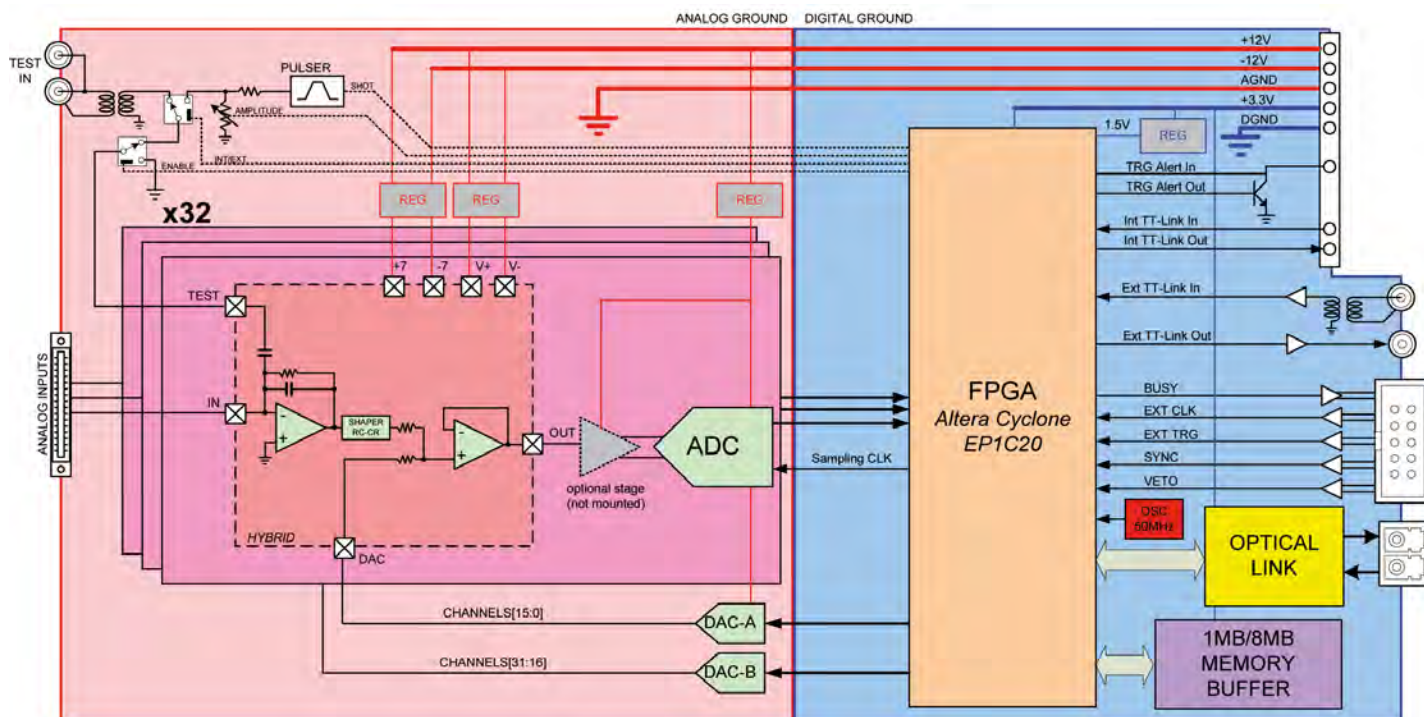

commands or an external signal, regardless the threshold crossing.

The data throughput of the SY2791 is directly proportional to the sampling and trigger rates; in theory, it is possible to perform the acquisition of the analog signals in continuous mode. For this purpose, the system features an internal autotrigger, whose period is chosen in order to have concatenated acquisition windows and continuous waveform digitizing. However, the data throughput of this operating mode can exceed the maximum readout speed allowed by the bandwidth of the optical link. Algorithms for the zero suppression and/or data compression can be added to the firmware of the FPGA in order to reduce the amount of data to transfer. Future developments foresee on-line data processing for the extraction of the energy and/or the time of the digitized pulses in order to further reduce the data throughput.

CAEN provides a software package that contains the drivers for the PCI board A2818, the libraries (both in C and LabVIEW) for optical link access and also some demos and examples of readout programs. Windows and Linux are both supported.

Developed in collaboration with ETH Zurich.

Features

- Complete detector readout system, designed for liquid argon TPC
- Easily customizable for a wide range of detectors
- 19" 4U crate housing 256 channels and the power supply
- Plug-in Preamplifiers on hybrid circuits (sold separately)
- 12-bit / 2.5 MSps digitizing
- 1 or 8 Mbyte memory buffer
- Independent channel self triggering
- TT-Link: synchronization and trigger distribution over a single wire
- 80MB/s Readout via daisy chainable optical link
- Libraries, Demos (C and LabVIEW) and Software tools for Windows and Linux

Accessories

A2818
PCI CONET Controller



A3818
PCI Express CONET2 Controller



AI2700
Optical Fiber Series



Cables for CONET Optical Link Networks

Ordering Option

Code	Description
WA2792XAAAA	A2792 - 32 Ch. 12Bit 2 MHz ADC for SY2791
WA2793XAAAA	A2793 - Power Supply for SY2791
WSY2791XAAA	SY2791 - TPC Readout System
WA2818XAAAA	A2818 - PCI Optical Link Controller
WAI2705XAAA	AI2705 - Optical Fibre 5 m. simplex
WA3818AXAAA	A3818 - PCIe 1 Optical Link Controller
WA3818BXAAA	A3818 - PCIe 2 Optical Link Controller
WA3818CXAAA	A3818 - PCIe 4 Optical Link Controller
WAI2720XAAA	AI2720 - Optical Fibre 20 m. simplex
WAI2703XAAA	AI2703 - Optical Fibre 30 cm. simplex
WAY2705XAAA	AY2705 - Optical Fibre 5 m. duplex
WAY2720XAAA	AY2720 - Optical Fibre 20 m. duplex

NEW

A2795

Liquid Argon TPC Readout Board

Overview

The A2795 is a readout board, ideally suited for liquid Argon TPC (Time Projection Chamber). The board is housed in a custom crate that contains 9 acquisition modules A2795, with 64 channels each. In total, one crate can read up to 576 channels. The analog signals coming from the detector can feed directly the inputs of the A2795s, in which the preamplifiers are arranged in arrays of plug-in hybrid circuits (8 channels each). This solution allows the preamplifier, which is detector and application dependent, to be re-designed or adapted to match the specific requirements.

Thanks to the feature of preamplifier on socket, the A2795 is also ready to use also in "Cold Option" configuration, using charge preamplifier front-end into the Liquid Argon and housing on board a custom voltage translators/amplifiers just for ADC dynamic range matching.

The preamplifier outputs are digitized by 12 bit 2.5MS/s ADCs and processed by the internal acquisition logic, implemented in a programmable FPGA, which provides the trigger logic, the data storage in local memory buffers and the readout through a proprietary optical link, controlled by the CAEN PCI express board A3818.

Thanks to this compact and modular solution, the readout electronics can be positioned very close to the detector, allowing the user to minimize the interconnecting cable length and its corresponding capacitance, reducing the noise. The optical fiber allows the system to be connected to the host PC as far as few dozens meters; the fiber guarantees easy cabling and absence of ground loops. One optical link of the PCI express card A3818 can control up to eight A2795 connected in daisy chain with the fibers. Because the A3818 owns four optical links, one single commercial PC can control and readout up to 2048 channels.

The system has been designed for the scalability: growing from a single crate with 576 channels up to experiments with thousands of channels is made easy by the TT-Link. This is a single wire bus (over a coaxial cable) connecting as many crates as needed, that distributes the same sampling clock to all the ADCs of the whole system and the same global commands, like triggers, start/stop acquisition, etc. thus keeping all the acquisition boards synchronized.

From the output of the preamplifier, the system operates as a waveform digitizer: the 64 serial outputs of the ADCs are connected to one FPGA which continuously reads the digital samples and writes them into an array of circular memory buffers. When the board is triggered, the FPGA saves the current buffer (i.e. an acquisition window); the event data are completed

by a header and a time tag. The acquisition can continue without dead-time in a new circular buffer. A global trigger common to all the channels can be issued using software commands or an external signal.

CAEN provides a software package that contains the drivers for the PCI express board A3818, the libraries (in C) for the access to the optical link and some demos and examples of readout programs. Windows and Linux are both supported.

Features

- Complete detector readout system, designed for liquid Argon TPC
- 64 Channels
- Preamplifiers on hybrid circuits (sold separately)
- 16 buffer (4K samples)
- TT-Link: synchronization and trigger distribution over a single wire
- Up to 85 MB/s Readout via daisy chainable optical link
- Libraries and Software tools for Windows and Linux

Accessories

A2818
PCI CONET Controller



A3818
PCI Express CONET2 Controller



AI2700
Optical Fiber Series



Cables for CONET Optical Link Networks

Ordering Option

Code	Description
WA2795XAAAA	A2795 TPC Readout board



CAEN Readout System for Multiplexed Signals

Overview

The requirement of including an analog multiplexer in some detector acquisition chain comes from the huge number of independent channels that have to be handled. Considering for instance the case of the silicon detector used as vertex tracker, the number of single independent channels is typically very high, in the order of hundreds or thousands of channels. Providing an ADC for each single channel would simply cost too much. A completely different approach has to be implemented. In a new scenario, the signal coming from the different detector channels will be pipelined in a single analog signal in which the whole information is collected: the pulse height (proportional to the charge and so to the energy released by the interacting particle) of the single channel. A not negligible acquisition dead time is the unavoidable compromise when using this kind of solution.

The CAEN Readout System for Multiplexed Signals is designed to manage the data readout from multiplexed ASIC chips (like Amplex, Gassiplex, VA and others) commonly used as front end electronics in Nuclear and Particle Physics whenever a large number of channels is required.

The system is able to provide all the relevant signals needed by the ASICs and to sample their multiplexed output following a precise time pattern according to the readout sequence.

The old-fashioned solution proposed in the past by CAEN and worldwide recognized as a standard was based on two VME modules: the V551 (in several versions) that in response to an external trigger that produce different pilot signals for the multiplexing chip(s) (Clock, Track & Hold, Clear) and the V550 that acquired the analog stream coming from the chip(s), digitize one single point per channels, perform a programmable pedestal subtraction, and matches the recorded value to the original channel. Moreover the V550 implemented a Zero Suppression algorithm using a programmable threshold in order to reduce the data throughput. Both the modules have become obsolete, difficult and expensive to produce and not up to date with the new CAEN data acquisition technology based on digitizers.

The new CAEN Readout System for Multiplexed Signals is based on two CAEN VME boards, V1495 and V1724, running dedicated firmware FW1495CRAMS and DPP-CRAMS. The V1495 is a general purpose board in which has been implemented a sequencer whose outputs (Track & Hold, Clock and Clear) are generated in LVDS and replicated

(NIM or TTL levels) on a piggyback A395D (8 NIM/TTL input/output channels piggyback). The V1495 is provided with three free slots that can house the A395D. The sequencer receives an external trigger and starts the conversion sequence by synchronizing the V1724 ADC board. V1724 is an 8 channels, 14-bit ADC. Receiving a start signal from one of the A395D housed in V1495, V1724 can handle the readout of the multiplexed signals coming from the ASICs according to the programmed sequence. Each V1724 input channel can handle an entire chain of several ASIC chips: one V1724 can manage up to 8 ASIC chains i.e. up to 16384 multiplexed channels. V1724 can also perform an effective Zero Suppression allowing the user to set an individual threshold for each multiplexed channel. Moreover, a programmable clock skew is available to compensate the increasing delay that affects the clock propagation through the ASIC chains in order to reach an higher readout rate.

The system lends itself, as a custom development, to be scaled-up by daisy chaining the relevant signals to build a multi board system made of multiple V1724 digitizers. A single V1495 equipped with 3 A395D can in fact feed up to 3 V1724 digitizers.

Features

- Readout System for Multiplexed Signals coming from ASIC chip as Amplex, Gassiplex, VA and others
- Based on V1495 and V1724 running dedicated firmware
- Each V1495 can house up to three A395D Sequencer
- Each V1724 can handle up to 8 ASIC chains
- Zero suppression with individual threshold setting
- Programmable clock skew to compensate the increasing delay of the clock propagating through the ASIC chains

Ordering Option

Code	Description
WFDPPCRAMSX	DPP-CRAMS - Digital Pulse Processing for CAEN Readout of Analog Multiplexed Signals (x724)
WF1495CRAMS	FW1495CRAMS - Sequencer firmware for CAEN Readout of Analog Multiplexed Signals (V1495)



**COMING
SOON**

DT5550 32 Channel DAQ System with Programmable FPGA and Sequencer

Overview

The DT5550 is a 32-channel digitizer for the acquisition of analog signals from ASICs used to read out multichannel detectors.

The typical application of this digitizer is the acquisition of analog signals from ASICs with multiplexed output where the user wants to manage the various readout configurations. In order to facilitate the process of development, a graphic software automatically generates the VHDL source code and C++ libraries, with no need for the user to learn VHDL or Verilog to configure the board. The generated code is still available to the user that can customize it as needed.

The DT5550 integrates a programmable sequencer that handles the readout of ASICs signals and a reconfigurable area where it is possible to implement trigger logic, external circuits management, and real time signals processing.

The system is based on a programmable FPGA that can be configured through a graphical developing platform: the DT5550 Compiler

The architecture of the digitizer DT5550 is designed to adapt, in a simple and intuitive way, the hardware acquisition architecture to the user configuration.

It is in fact a read out system based on 32 12-bit/20 MS/s ADCs, used to sample up to 32 analog inputs.

The data acquired by the ADCs are then forwarded to an FPGA device in which the user can load its own custom firmware. The FPGA can then be used as advanced digital sequencer for the integrated management of the readout process of the system. Obviously the synchronization between digital and analog sampling is assured by the management of the system through the FPGA device.

Features

- 32 analog acquisition channels
- 80 digital channels for the sequencer and the management of external circuits
- Integrated system for the management of ASIC's with multiplexed analog output
- USB3 bus for fast transfer of data (> 300 MB/s)
- 8 I/O CMOS digital connector for external synchronization
- Integrated 2 SPI master core and two I2C master core
- Graphical software tool for the automatic generation of firmware
- C++ libraries automatically generated as a function of the firmware

DT5550 Compiler

The DT5550 features a graphic software that integrates the development of the sequencer and the logic of digital imaging. The software provides logical functions, edge detector, gate and delay, trigger logic, counters, timers, PC programmable registers and state machine to realize a whole readout logic for ASICs connected to the DT5550. The DT5550 compiler allows the user to generate, in an automatic way and with a few clicks, a sequencer suitable for several applications. The software automatically generates the necessary VHDL code through an integrated compiler (with no need to launch Xilinx ISE outside the application) and to upload the firmware. The compiler allows the creation of firmware registers to change, in real time, the functional parameters (i.e. delay of the acquisition start, compared to the trigger); it then automatically generates a C++ library support for the integration between hardware and software.

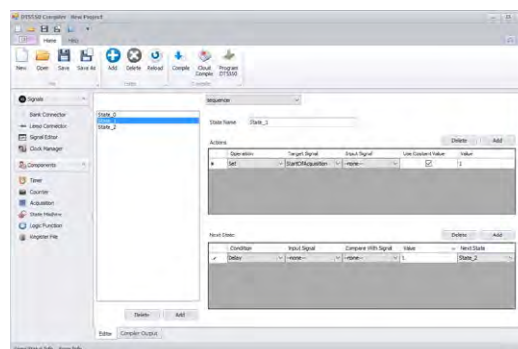

Ordering Option

Code	Description
WDT5550XAAAA	DT5550 - 100 Ω input impedance
WDT5550BXAAA	DT5550B - 1 k Ω input impedance

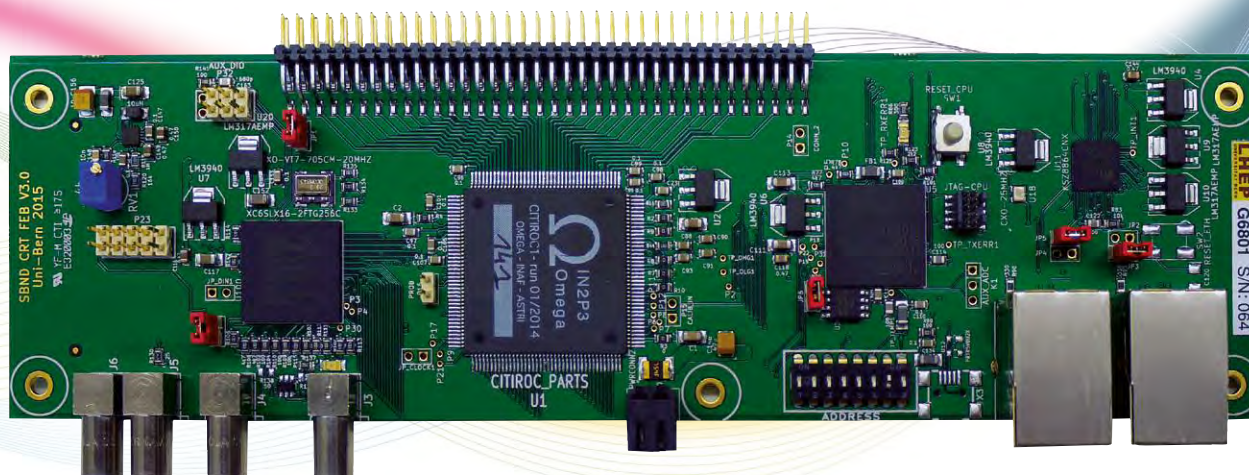

A1702

32 Channel Silicon Photomultipliers Readout Front-End Board

NEW

Features

- Provides bias voltage in the range of 40-90 V individually adjustable for each of 32 SiPMs
- Amplification and shaping of the SiPMs output pulse on each of 32 channels
- Discrimination of shaped signal at configurable level from 0 to 50 SiPMs photo-electrons
- Providing basic coincidence of signals from each pair of adjacent even-odd channels
- Allows to trigger only on events that happen in coincidence with event in a group of other A1702 (event validation)
- Formation of the trigger for digitization of the signal amplitude
- Formation of the time stamp with respect to an input reference signal with 1 ns accuracy
- Digitization of signal amplitude of all 32 channels
- Data buffering
- Efficient back-end communication based on Ethernet standard
- Firmware upgrade via back end Ethernet link

Overview

The A1702 Front-End Board is a custom design developed by the Albert Einstein Center for Fundamental Physics of the University of Bern for the readout of SiPM arrays used in the veto system of Liquid Argon Neutrino Experiments. Given the increasing use of SiPM in Physics Experiments, this solution can become a valid approach for a variety of applications thanks to its flexibility and channel density.

The analog input signal is processed by CITIROC a 32-channel ASIC from Weeroc. For each channel the chip provides charge amplifier with configurable gain, fast shaping with the peaking time of 15 ns and slow shaping with configurable peaking time in the range of 12.5 ns to 87.5 ns. Signals from the fast shapers are discriminated (programmable threshold) and produce digital signals (T0-T31) for event triggering. These 32 signals are routed to XILINX Spartan-6 FPGA chip, where the basic input coincidence and event triggering logic is realized. The analog signal for all channels can be stored in the ASIC Sample-and-Hold (S/H) circuit and multiplexed to a single analog output. This output is routed to the ADC (part of NXP LPC4370 ARM micro-controller chip).

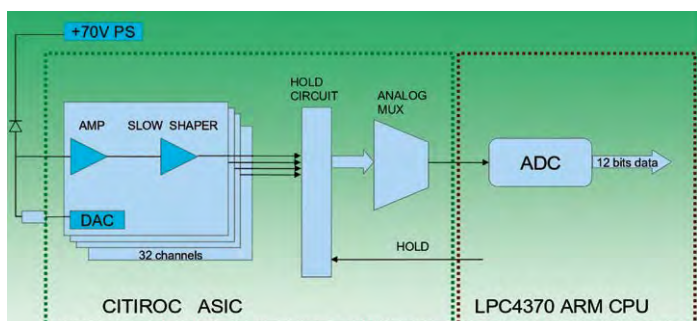

Figure 1: Block-scheme of analog signal processing circuit.

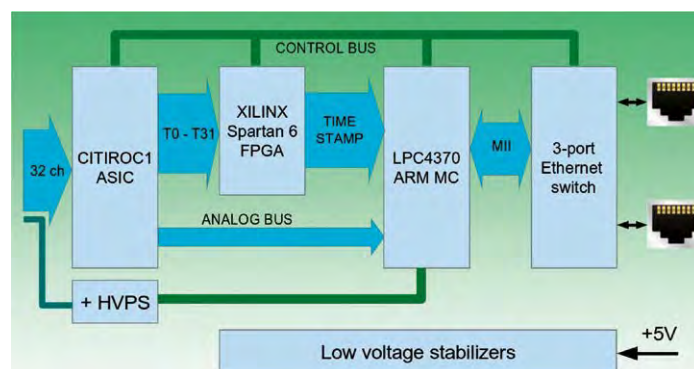

Figure 2: Block-scheme of the Front-End Board



Figure 3: Desktop version of the Front-End Board (DT5702)

Ordering Options

Code	Description
WA1702XAAAA	A1702 - 32-channel SiPM readout Front-End Board
WDT5702XAAAA	DT5702 - 32-channel SiPM readout Front-End Board BOXED



DIGITAL DETECTOR EMULATORS

CAEN Digital Detector Emulators are the multichannel instruments for the emulation of complex radiation detection systems. Thanks to an advanced digital synthesization algorithm, they can operate as Pulsers, Function Generators & Emulators, offering an unprecedented flexibility and signals customization capability.

- DT5810 Fast Digital Detector Emulator
- DT4800 Micro Digital Detector Emulator
- DT5800-NDT6800 Digital Detector Emulator



Introduction to Digital Detector Emulators

Your powerful user-friendly solution for the emulation of any detection setup

- Energy spectrum emulation
- Time distribution emulation
- Pile-up emulation
- Noise emulation
- Multiple shapes emulation (DT4800 excluded models only)
- Programmable analog delay generator (2 channel versions only)
- Correlated events generation (2 channel versions only)

The Digital Detector Emulators are multichannel instruments for the emulation of radiation detection systems.

These devices represent a hardware application of the well-known Monte Carlo simulation method, synthesizing a continuous stream of pulses according to a user programmable set of statistical distributions such as energy spectra, time distribution, noise, etc.

In addition, energy spectra and template waveforms acquired by other instrumentation (MCAs, digital oscilloscopes, etc.) can be loaded as a source of the emulation.

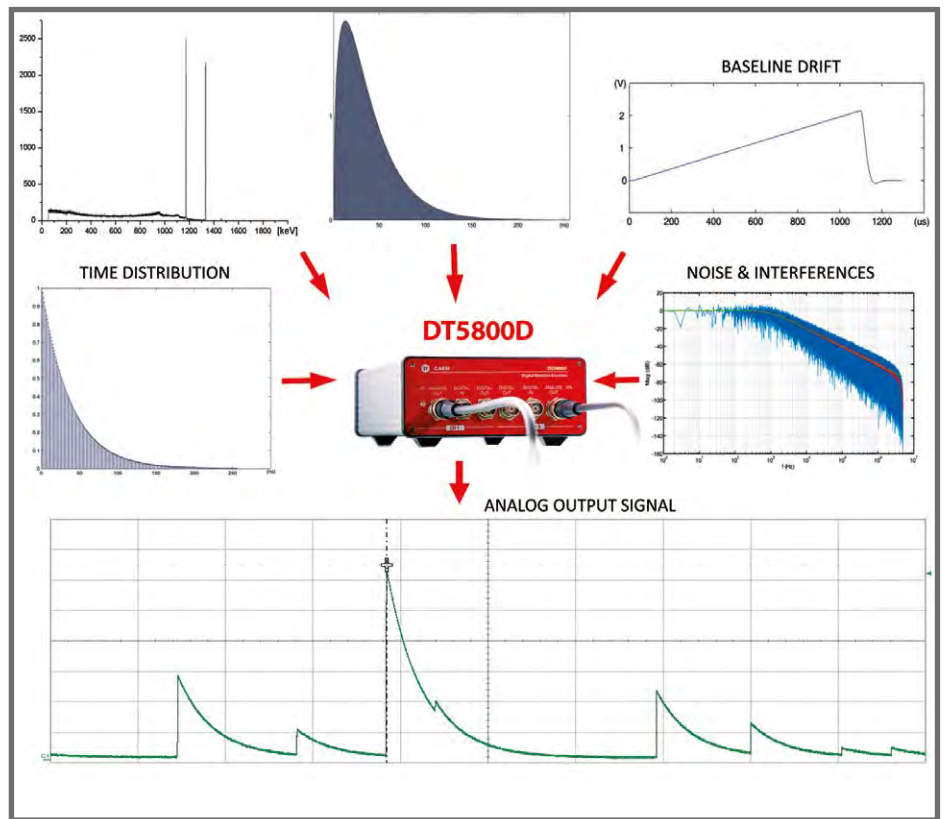

Block scheme of the event generation process.

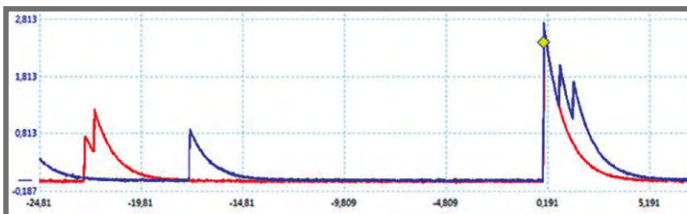

Generation of correlated events. CH1 in red, CH2 in blue. The yellow mask shows a correlated event sharing the same energy and timing in both channels.

Signal pile-up is another experimental condition that can be fully emulated and controlled by the user.

When the emulation process is reset, the sequence can be either re-initialized with new random data or reproduced the same many times, in order to study, for example, the effect of acquisition changes on the same data set.

Each channel can be independently programmed with its own statistics.



Introduction to Digital Detector Emulators

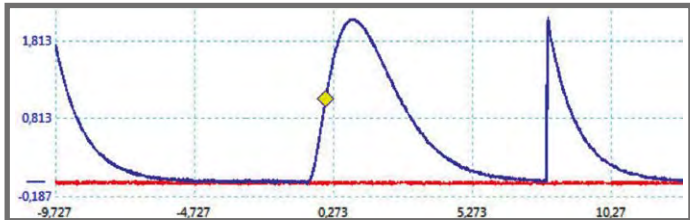

Two different shapes in the same output channel.

Moreover, the user can either run different channels by uncorrelating or correlating them in different ways:

1. Channel 1 sequence can be a copy of Channel 0 one shifted in time
2. A subset of events from Channel 1 can share the same Energy Spectrum of Channel 0
3. The two channels can work in a Master/Slave configuration, in which Channel 0 works as a trigger for Channel 1 that conserves its own statistics

Another interesting feature (DT4800 excluded) is the possibility to generate different pulse shapes on the same channel with a predefined "mixture" percentage of the two, in order to emulate for example neutron pulses in a gamma ray background. The capability to add different noise and interference figures improves the emulation process, giving the possibility to operate out of ideal but not realistic conditions.

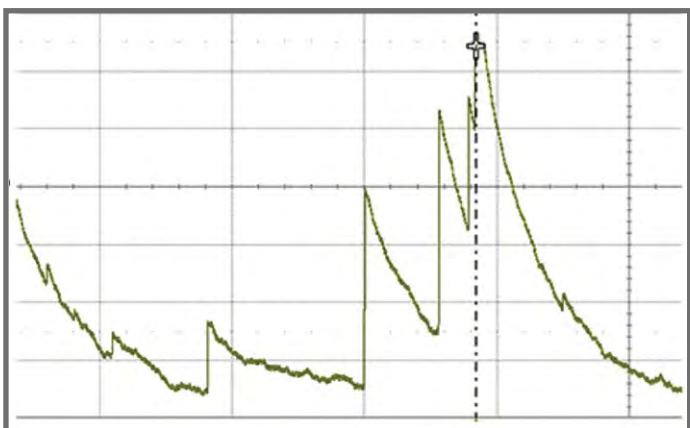

Final analog output of the Digital Detector Emulator.

The Digital Detector Emulators are controlled by a dedicated Control Software with advanced graphical user interface for a full control of all the emulation parameters.

These features, together with the possibility to work as waveform/function generators, make the Digital Detector Emulators the perfect tools for testing and developing DAQ solutions, bringing an experimental setup on your desktop.

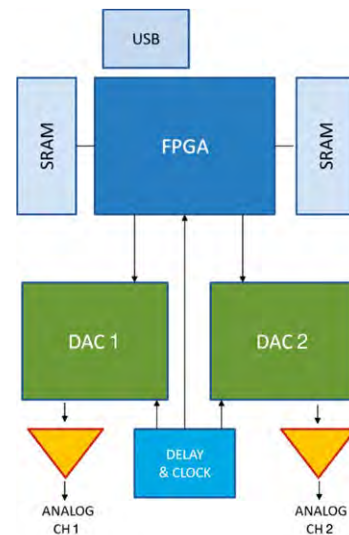

Block diagram of the Digital Detector Emulator.

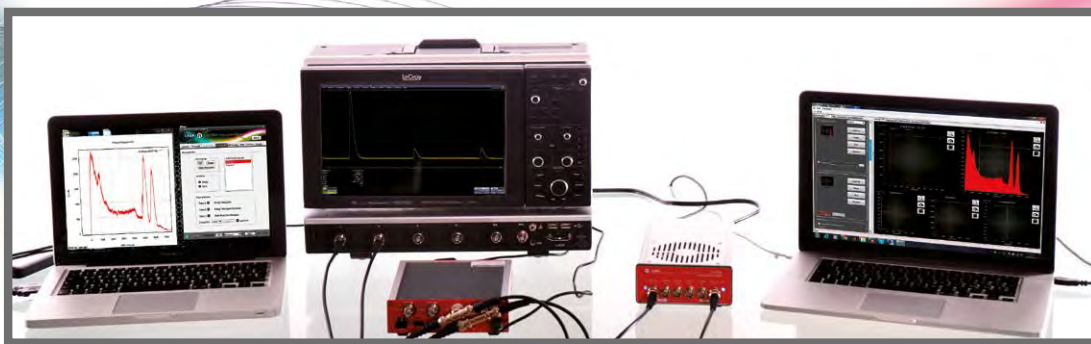

Applications

Digital Detector Emulators

Remote Experimentation

Through the use of CAEN digitizers and digital MCAs it is possible to acquire and store both waveforms and energy spectra from real radiation detectors. The resulting files can be imported in the Digital Detector Emulators and used as a source for the emulation process.

It is therefore possible to emulate the real setup even without having a direct access to it.

Moreover, the user can modify the original experimental conditions by tuning emulation parameters like rate, pile-up, noise, etc. This extends the emulation process beyond the experimental conditions achievable in a lab.

Time To Digital Converter

The Digital Detector Emulators can be coupled with a CAEN TDC module for a precise test of time resolution.

Usually, a delay generator or a simple pulser are used to generate signals with fixed amplitude and shape. With Digital Detector Emulators it is possible to test timing resolution in a more general condition, using signals with variable amplitude and shape and adding the typical issues that affect real setups like noise, baseline drift and pile-up.

Pulse Shape Discriminator

In several applications the ability to distinguish different pulse shapes is important to discriminate the kind of particles interacting within the detector. This is, for example, the case of neutron-gamma discrimination where neutron sources are difficult to handle.

The Digital Detector Emulators are able to simulate different pulse shapes on the same channel (DT4800 excluded) allowing for detailed studies of such applications.

Correlated Events

In applications where multiple detectors are used, it is often required to extract correlated events from the background.

In addition to the energy spectra independently programmable on each channel, the Digital Detector Emulators (DT4800 excluded) are able to define a third common spectrum that is added to the others.

In this way, it is possible to test and measure the performances of user defined coincidence algorithm.

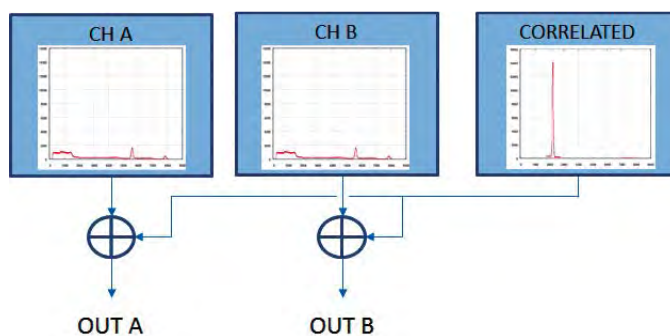

Energy spectrum correlation among channels

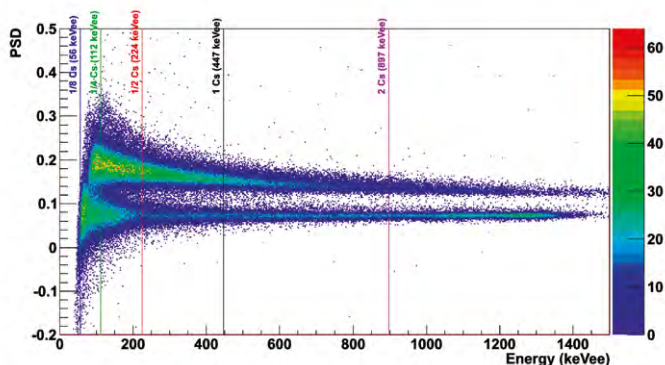

Pulse Shape Discrimination between neutrons and gammas

Digital Detector Emulators

FORM FACTOR



DESKTOP

INTERFACES

USB 3



DT5810 Fast Digital Detector Emulator

NEW

Overview

The DT5810 is the model of the Detector Emulator family with the fastest signal output. Thanks to an updated and faster DAC it is now possible to emulate the behavior of the fast detectors on the market with 1 ns rise time. In addition this new model features an Analog Input that can be used to acquire spectra from a detector and emulate them later. It can also acquire signals coming from the detector and reproduce them real time together with generate pulses. The output amplitude is selectable at ± 2 V with 50 Ω or ± 8 V at high impedance.

The unit can operate in the same three modes as the 5800 Family (Pulsar Mode, Emulation Mode and Waveform Generator Mode). In addition the minimum programmable delay is 1 ns/step, and the Function Generator supports only standard waveforms: e.g. sinusoidal, squared, ramp shape, etc...

Features

- Pulsar/Emulator/Function Generator operating modes
- Energy spectrum emulation
- Time distribution emulation
- Custom signal shape emulation
- Pile-up emulation
- Noise and periodic interference emulation
- Baseline drift
- 1 ns/step programmable delay generator
- Correlated signals generation on the two output channels
- Two shape on the same channel for testing the pulse shape discrimination
- Continuous and pulsed reset pre-amplifier emulation



**FREE
DOWNLOAD**



Screenshot of the pulse generation in the graphical user interface provided with the Digital Detector Emulators..

Ordering Option

Code	Description
WDT5810DXAAA	DT5810D - Dual Channel Desktop Digital Detector Emulator with channel correlation

FORM FACTOR



DESKTOP

INTERFACES

USB 2 (Mini USB)

**NEW**

DT4800

Micro Digital Detector Emulator

Overview

The DT4800, called Micro Digital Detector Emulator, is the most compact and cost effective model of the Detector Emulator family and it is particularly suited for single detector emulation and educational purposes. The unit features one analog output, one digital input, and one digital output. As a Pulser it can generate exponential decay signals with programmable Rise Time and Fall Time up to a rate of 1 Mcps. The rate can be fixed or it can follow a Poissonian distribution.

In Emulation mode the unit can reproduce signals from a real energy spectrum that can be uploaded in the form of CSV or ANSI N42.42 files. A database of nuclides is provided to generate specific emission lines and Gaussian noise can be added. An user friendly control software is provided with the unit.

Features

- Pulser/Emulator operating modes
- Real Energy spectrum emulation
- Time distribution emulation (Poisson)
- Noise emulation
- Continuous pre-amplifier emulation
- Nuclides database
- User Friendly Control SW with Graphical User Interface

**FREE
DOWNLOAD**

Isotope selection and noise emulation interface.

The isotopes database interface.

Ordering Option

Code	Description
WDT4800XAAAA	DT4800 - Micro Digital Detector Emulator

Digital Detector Emulators

FORM FACTOR



NIM DESKTOP

INTERFACES

USB 2



DT5800 - NDT6800 Digital Detector Emulators

Features

- Pulser/Emulator/Arbitrary Waveform Generator operating modes
- Energy spectrum emulation
- Time distribution emulation
- Custom signal shape emulation
- Pile-up emulation
- Noise and periodic interference emulation
- Baseline drift
- 12 ps/step programmable delay generator
- Correlated signals generation on the two output channels
- Multiple shapes on the same channel for testing of pulse shape discrimination
- Continuous and pulsed reset pre-amplifier emulation



**FREE
DOWNLOAD**

Overview

The DT5800 and NDT6800 are Dual Channel Detectors Emulators. They can be operated as Desktop units and the NDT6800 can also be used in a NIM crate. These instruments share the same functionalities and can operate in three modes:

Pulser Mode, Emulation Mode and Waveform Generator Mode. The output generated by the device can go up to 2 V (4 V in case of high Z) and the maximum pulse rate is 10 Mcps (5 Mcps in Poisson statistics mode). In the detector emulator operating mode, the system is able to emulate with high accuracy a radiation detection system from the detector output to its related front-end electronics. The user can program different emulation parameters like signal shape distributions, energy spectra, time distribution, as well as noise characterization and baseline drift.

Thanks to the 12 ps/step delay generator they are particularly suited for timing application. Moreover, the multiple shapes capability can be used for pulse shape discrimination applications. The two channels can be correlated either with the same or different statistical distributions.



Screenshot of an emulated spectra in the graphical user interface provided with the Digital Detector Emulators.

Ordering Option

Code	Description
WDT5800DXAAA	DT5800D - Dual Channel Desktop Digital Detector Emulator with channel correlation
WNNT6800DXAA	NDT6800D - Dual Channel NIM/Desktop Digital Detector Emulator with channel correlation

Emulator Comparison Table

	DT4800	DT5800 - NDT6800	DT5810
OVERVIEW			
Channels	1	2	2
Energy Resolution (Pulser)	14-bit	16-bit	16-bit
Energy (Emulation)	14-bit	14-bit	14-bit
D/A Resolution	14-bit	16-bit	16-bit
D/A Sample rate	200 MHz	125 MHz	1 GHz
Output Range (Fast Edge)	± 2.5 V (50 Ω), ± 5.5 V (hi-Z)	± 2 V (50 Ω), ± 4 V (hi-Z)	± 2 V (50 Ω), ± 4 V (hi-Z)
Output Range (Slow Edge)			± 8 V (hi-Z)
TIMEBASE			
Constant Rate Generation	Yes	Yes	Yes
Poisson Distribution	Yes	Yes	Yes
Maximum Rate	1 Mcps	10 Mcps / 5 Mcps (Poisson)	50 Mcps/ 20 Mcps (Poisson)
Deadtime emulation	No	Yes	Yes
SHAPE			
Exponential Signal (Digital RC Mode)	Yes	Yes	Yes
Memory based arbitrary shape generation	No	Yes	Yes
Decay Time	from 20 ns to 1 ms	from 20 ns to 10 ms	from 5 ns to 10 ms
Signal Shape Length		4096	4096
Multiple shapes on a single channel	No	Yes (2 different)	Yes (4 different)
Minimum rising time (fast mode)	7 ns	8 ns	1 ns
Minimum rising time (slow mode)	30 ns	30 ns	16 ns
NOISE			
Random Noise	No	Yes	Yes
White Noise (Gaussian)	Yes	Yes	Yes
Random Walk	Yes	Yes	Yes
1/f noise	No	Yes	Yes
Interference Generation	No	Yes	Yes
BASELINE			
Baseline drift	No	Yes	Yes
CORRELATED EVENTS SIMULATION			
Correlated events simulation	No	Yes	Yes
Time resolution		12 ps	1 ns
Additional channel for correlated event with independent statistics	No	Yes	Yes
IO			
Digital IO	1 In / 1 Out	1 In / 1 Out per channel	1 In / 1 Out per channel
External Trigger	Yes	Yes	Yes
Trigger Out	Yes	Yes	Yes
SEQUENCE GENERATION			
Sequence of energy and time	No	Yes	Yes
FUNCTION GENERATION			
Arbitrary Waveform Generation	No	1 Mcps wave	No
Function Generation	No	Yes (10 MHz)	Yes (100 MHz)
ANALOG INPUT			
Analog Input	No	No	Yes - 1 channel
Signal recording	No	No	Yes
Pulse Height Analysis	No	No	Yes
ADC N bit			14
ADC sample rate			150 MS/s
Input dynamic range			0.75 V, 2 V, 5 V, 10 V
CONNECTIVITY			
Interface	USB 2 (Mini USB)	USB 2	USB 3
Power Supply	5 V - 400 mA	12 V - 4 A	12 V - 4 A
Display Interface	No	No	Yes
SOFTWARE			
DLL for automation	Yes (c++)	Yes (.net)	Yes (c++)
SOFTWARE: CAEN Detector Emulator	No	Yes	Yes
SOFTWARE: Easy Onetouch (educational simplified software)	Yes	No	No

The natural complement to all experimental set-up are the accessories. They help the management of the different modules, for instance making the communication easier or adapting them to each other. A proper choice of the accessories will therefore turn into an easier and reliable control of the experimental parameters, for better results. CAEN offers a selection of accessories that range from controllers to attenuators, adaptors, etc.

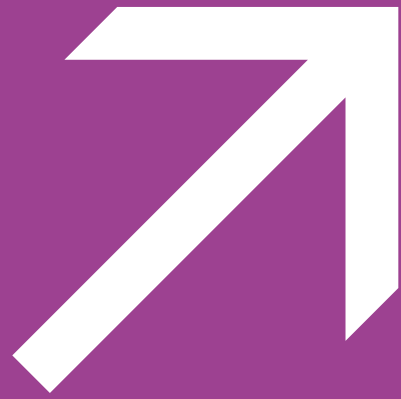

Optical Controllers

Adapters

HV Connectors

Fixed Attenuators

HV Filters

Splitters

Cables



A2818 PCI CONET Controller

The A2818 is a 32-bit 33 MHz PCI card, which allows the control, through a standard PC, of up to 8 CAEN Optical Slave Cards (CAEN VME Bridge or Digitizers). The communication protocols used are the CONET1 or the new CONET2 (A dedicated firmware for the desired protocol must be installed on the board). Optical fiber cables are used as physical transmission line (see AI2700 Optical Fiber Series). The card drivers, together with C functions libraries and demo programs are provided for both Windows and Linux Users.

Code	Description
WA2818XAAAA	A2818 - PCI Optical Link Controller



A3818 PCI Express CONET2 Controller

The A3818 is a PCI Express card that can plug into any x8/x16 PC PCI Express slot (1.1 or higher), which allows the control up to 4 CONET2 independent networks (each network can be made of up to 8 CONET2 slaves).

The communication path uses optical fiber cables as physical transmission line (see AI2700 Optical Fiber Series).

The card drivers, together with C functions libraries and demo programs are provided for both Windows and Linux Users.

Code	Description
WA3818AXAAAA	A3818 - PCIe 1 Optical Link
WA3818BXAAAA	A3818 - PCIe 2 Optical Link
WA3818CXAAAA	A3818 - PCIe 4 Optical Link



A1481 Kill Signal Adapter for N14xx Series

The A1481 Kill Signal Adapter is a pluggable adapter that allows external 5Volt signal level to enable the HV channel of the N14xx NIM HV Power Supply series. This is necessary in order to use the modules with some detectors. Kill input is provided through LEMO connectors (1, 2 and 4 channel versions are available).

Code	Description
WA1481XAAAA	A1481 - 4 Ch. N14xx Kill Signal Adapter
WA1481A2AAAA	A1481A - 2 Ch. N14xx Kill Signal Adapter
WA1481B1AAAA	vA1481B - 1 Ch. N14xx Kill Signal Adapter

A385 - A392 16 Channel LEMO Adapters

The A385 and A392 allows to provide respectively the V785 and the V792, with LEMO 00 input connectors, adapting them to the flat connectors. The A385 and A392 fit into one 17+17 pin male flat type connector and are provided with 16 LEMO 00 male connectors each. The A385 can also be used to match the output flat connectors of the N568E/EB/ELC Spectroscopy Amplifier with the LEMO input connectors of a discriminator (such as V812, V895 etc.). The devices are completely passive mechanical adapters for analog signals and feature 50 cm long cables.

Code	Description
WA385XAAAAA	A385 - 16 Channel Cable Adapter (Flat to LEMO) for V785, 50cm / ±10% cables
WA392XAAAAA	A392 - 16 Channel Cable Adapter (Flat to LEMO) for V792, 50cm / ±10% cables
WA385XMAAAAA	A385M - 16 Channel Cable Adapter (Flat to LEMO) for V785, 1m / ±10% cables
WA392XMAAAAA	A392M - 16 Channel Cable Adapter (Flat to LEMO) for V792, 1m / ±10% cables

A654 MCX to LEMO Cable Adapters

The A654 adapter allows to adapt the MCX input connectors (used on CAEN Waveform digitizers) into LEMO 00 connectors.

CAEN provides kits with 1, 4, 8 cable adapters.

Code	Description
WA654XAAAAA	A654 - Single Channel MCX to LEMO Cable Adapter
WA654K4AAAAA	A654 KIT4 - 4 MCX TO LEMO Cable Adapter
WA654K8AAAAA	A654 KIT8 - 8 MCX TO LEMO Cable Adapter

A659 MCX to BNC Cable Adapters

The A659 allows to adapt one MCX input connector (used on most digitizers) into one BNC connector, through 1 meter long RG174 cable.

CAEN provides kits with 1, 4, 8 cable adapters.

Code	Description
WA659XAAAAA	A659 - Single Channel MCX to BNC Cable Adapter
WA659K4AAAAA	A659 KIT4 - 4 MCX TO BNC Cable Adapter
WA659K8AAAAA	A659 KIT8 - 8 MCX TO BNC Cable Adapter



64 Channel Adapter for LEMO Connector (VME) **A746B**

The A746B allows to adapt one ERNI SMC-114805 high density flat connector (used on V1740 and VX1740) into 64 LEMO connectors.

Code	Description
WA746BXAAAAA	A746B - 64 Ch. Adapter for LEMO connector

32 Channel Adapter for LEMO connector (NIM) **A746D**

The A746D allows to adapt one ERNI SMC 114805 high density flat connector (used on N6740) into 32 LEMO connectors.

Code	Description
WA746DXAAAAA	A746D - 32 Ch. Adapter for Lemo connector

32 Channel Adapter for LEMO Connector (DT) **A746E**

The A746E allows to adapt one ERNI SMC 114805 high density flat connector (used on DT5740) into 32 LEMO connectors.

Code	Description
WA746EXAAAAA	A746E - 32 Ch. Adapter for Lemo connector

16 Channel to 2x8 Channel Cable Adapter **A954**

The A954 allows to adapt one 17+17-pin, female Header-type connector (16 pin couples connected) into two 8+8-pin, female Header-type connectors, through one split 50 cm long flat cable (split length is 20 cm). It can be used on all CAEN modules featuring the 3M 3431 Connector.

Code	Description
WA954XAAAAA	A954 - 16 Channel to 2x8 Channel Cable Adapter

32 Channel Cable Adapter for V767, V862, V1190, VX1190, Vx495, DT5495 **A967**

The A967 allows to adapt one Robinson Nugent high density flat connector (used on V862, V767, V767A, V1190A/B, VX1190A/B, V1495, V2495 and DT5495) into two 17+17-pin Header-type male connectors with locks through two 25 cm long flat cables.

Code	Description
WA967XAAAAA	A967 - 32 Channel Cable Adapter (1x32 to 2x16) for V767, V862, V1190, VX1190, Vx495, DT5495

16 Channel Impedance Adapter **A992**

The A992 is a plug-in card, provided with 16 independent input channels on a 34 pin male header connector, to be inserted into the V792 QDC's front panel connectors (one V792 requires two A992 adapters). The card matches the QDC's input impedance from 50 Ω to 110 Ω , decouples the QDC's and the source's ground and converts differential signals into single ended signals.

Code	Description
WA992XAAAAA	A992 - 16 Channel Impedance Adapter for V792

USB RS485 Adapter Board **N1568ADAT**

The N1568ADAT converts from USB to RS-485. The converter allows to use the modules with laptop computers that do not have a serial port. The device is provided with drivers and installation instructions supporting the most used OS's

Code	Description
WN1568ADATXX	N1568 - USB-RS485 Adapter





A995 Insertion/Extraction Tool for A996

The A995 Insertion/Extraction Tool allows to either insert or remove the pin contacts from the 52 Pin HV cable connector (Mod. A996) designed to be used with the CAEN boards featuring the Multipin connector Radiall 691803004 type. The A995 has one “half-tube” needle on one side for contact insertion and one “tube” needle on the opposite side for contact extraction.

Code	Description
WA995XAAAAA	A995 - Insertion/extraction tool Radiall 282549024 for A996

A996 52 Pin Cable Connector

The A996 is the 52 Pin HV cable connector designed to be used with the CAEN boards featuring the Multipin connector Radiall 691803004 type. The connector must be assembled by using the A995 Insertion/Extraction Tool, which allows to either insert or remove the pin contacts from the connector.



Code	Description
WA996XAAAAA	A996 - 52 pin cable connector

A997 HV Coaxial Cable Connector for CPE HV

The A997 is the female cable connector to be mated with the CPE 23.100.151-046 type male panel connector (used on boards with output larger than 12 kV, such as A1526, A1523, A1524, AG523, AG524).



Code	Description
WA997XAAAAA	A997 - HV coaxial cable connector for CPE HV

A309 - A310 - A311 - A312 - A313 Single Channel Fixed Attenuators

The A309, A310, A311, A312 and A313 are simple devices that provide a fixed attenuation (1, 3, 6, 12 and 20 dB respectively). The attenuators are 50 Ω adapted and feature LEMO female type connectors; they do not require any power supply since they are made up of resistive cells.



Code	Description
WA309XAAAAA	A309 - Single Channel Fixed Attenuator (1dB)
WA310XAAAAA	A310 - Single Channel Fixed Attenuator (3dB)
WA311XAAAAA	A311 - Single Channel Fixed Attenuator (6dB)
WA312XAAAAA	A312 - Single Channel Fixed Attenuator (12dB)
WA313XAAAAA	A313 - Single Channel Fixed Attenuator (20dB)

AI2700 Optical Fiber Series

Cables for CONET1/CONET2 Optical Link Networks.



Code	Description
WAI2703XAAAA	AI2703 - Optical Fibre 30cm. simplex
WAI2705XAAAA	AI2705 - Optical Fibre 5 m. simplex
WAI2720XAAAA	AI2720 - Optical Fibre 20 m. simplex
WAI2730XAAAA	AI2730 - Optical Fibre 30 m. simplex
WAI2740XAAAA	AI2740 - Optical Fibre 40 m. simplex
WAY2705XAAAA	AY2705 - Optical Fibre 5 m. duplex
WAY2720XAAAA	AY2720 - Optical Fibre 20 m. duplex
WAY2730XAAAA	AY2730 - Optical Fibre 30 m. duplex

A483 HV Bidirectional Passive HV Filter

The A483 is a bidirectional passive HV filter. The filter has a Maximum Input Voltage of ± 8 kV. The Ripple Rejection is 20 dB (26 dB @ 36 KHz), measured with 50 mVpp (40 mVpp @ 36 KHz) input ripple, 8 kV Input DC Voltage and 8 μ A Output Current. It does not require any power supply since it is made up of passive components. The module is designed to be used together with a HV Power Supply when a low ripple is required. The High Voltage input and output are provided by SHV connectors.



Code	Description
WA483XAAAAA	A483 - HV Filter (8KV)

Splitter **A315**

The A315 splits one input on two output signals. All the connectors are LEMO female type. The splitter is adapted for 50 Ω lines. The device is completely passive (no power supply is required); the amplitude on each output is one half of that on the input.

Code	Description
WA315XAAAAAA	A315 - Splitter

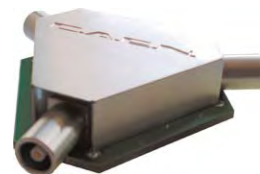

Clock Distribution Cable **A317**

The A317 - Clock Distribution Cable allows to perform CLK OUT - CLK IN connection on V17XX digitizers.

Code	Description
WA317XAAAAAA	A317 - Clock Distribution Cable



Single-Ended to Differential Cable Adapter **A318**

The A318 cable adapter can be typically used with CAEN digitizers to operate in external clock mode. It allows to convert a single-ended clock signal, coming from an external clock unit, into differential to be accepted by the dedicated digitizer front panel input connector (CLK-IN).

Code	Description
WA318XAAAAAA	A318 - Single-ended to Differential cable adapter



HV Adapters (Multipin to SHV coaxial) **A1015x - A64x - R64x**

The A64X - R64x is a family of cable adapters, that allow to adapt the high density SYx527 boards connectors (52pin Radial and DB37) to the SHV coaxials. The adapters in this family provide the INTERLOCK and SHIELD connections through LEMO connectors and are available both as desktop and 19" rack modules.

The A1015VM is not an adapter but an analog voltage monitor for A1515/A1515TG/A1515QG boards. It allows to monitor the voltage level for the triple or quadrupole GEM (the channels are internally stacked). The voltages can be monitored in two ways:

- in absolute value: checking the GEM or Transfer voltage with respect to the mass reference
- in differential value: checking the voltage level on each GEM or Transfer

Code	Description
WA646XAAAAAA	A646 - DB37 to SHV Adapter for 12 ch HV Boards (Max: 500V - Desktop)
WA647XAAAAAA	A647 - Multipin to SHV Adapter for 24 ch HV Boards (Max: 8kV - Desktop)
WA648XAAAAAA	A648 - Multipin to SHV Adapter for 48 ch HV Boards (Max: 3kV - Desktop)
WA649XAAAAAA	A649 - Multipin to SHV Adapter for 32 ch HV Boards (Max: 3kV - Desktop)
WA649BXAAAAA	A649B - Multipin to SHV Adapter for 32 channel HV Boards (max 8kV)
WR647XAAAAAA	R647 - Multipin to SHV Adapter for 24 ch HV Boards (Max: 8kV - 19" Rack)
WR648XAAAAAA	R648 - Multipin to SHV Adapter for 48 ch HV Boards (Max: 3kV - 19" Rack)
WR649XAAAAAA	R649 - Multipin to SHV adapter for 32 ch HV Boards (Max: 3kV - 19" Rack)
WR649BXAAAAA	R649B - 19" Multipin to SHV Adapter for 32 channe HV Boards (Max 8kV)
WA1015XAAAAA	A1015 - 16 Floating Channel Multipin Radial to SHV connector Adapter for A1515 board
WA1015GXAAAA	A1015G - 14/16 Stacked Channel Multipin Radial to SHV connector Adapter for A1515TG/A1515QG board
WA1015VMXAAA	A1015VM - Analog Voltage Monitor for A1515/A1515TG/A1515QG board



General Purpose 1U Fan Unit **A83xx**

The A83xx is a 19" Rack mount 1U fan unit. The unit provides a 450 m³/h air flow (50 W power requirement)

NEW

Code	Description
WA83XXFANXAA	A83xx General Purpose 1U Fan Unit 220Vac
WA83XXFANXBA	A83xxB General Purpose 1U Fan Unit 110Vac





Power Supply Connectors

APP PC5933T

n. 1

Factory Name	APP PC5933T
Description	Vertical contact MINI P/CLAW APP PC5933T type
Other features	-



APP30 1317G4

n. 2

Factory Name	APP30 1317G4 / PP30 1327BK / PP30 1327G6BK
Description	APP30 1317G4 type
Other features	APP30 MOUNTING WINGS 1399G8BK type - Black: PP30 1327G6BK APP - Red: PP30 1327BK APP - Vert. contact PP30 1317G4 APP - Mounting: PP30 MOUNTING WINGS 1399G8BK APP



AMP 75

n. 3

Factory Name	AMP 201311-3
Description	HV multipin connector
Other features	Mates with AMP 201310 cable connector; suitable for operation in the $-55 \div +150$ °C range

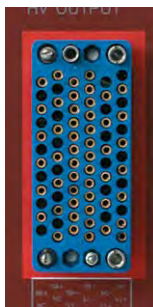

Radiall 52

n. 4

Factory Name	Radiall 691 803 004
Description	HV multipin connector
Other features	Mates with Radiall 691 802 002 and CAEN Mod. A996 cable connectors; up to 9 kV supported



SHV

n. 5

Factory Name	Radiall R317580
Description	HV coaxial connector
Other features	Supports up to 8 kV



CPE 3 Pole

n. 6

Factory Name	CPE 28-019
Description	HV 3 Pin Panel Male Connector
Other features	supports up to 18 kV



CPE HV

n. 7

Factory Name	CPE 23.100.151.046
Description	HV Coaxial Connector
Other features	supports up to 18 kV; mates with HV Cable Connector CPE 23.100.052.045



DB37

n. 8

Factory Name	FCI DCPV37S300GT
Description	DB37 Female connector
Other features	-



Brass hexagon head bolt

n. 9

Factory Name	RS Stock no. 483-2390
Description	Brass hexagon head set screw, M6x30mm
Other features	-



LEMO HV

n. 10

Factory Name	LEMO HV ERA3S415CTL
Description	LEMO HV Female (panel)
Other features	Mates with LEMO HV MALE FFB3S415CPAC-10W



D-Sub 8W8 socket

n. 11

Factory Name	DC8W8SA00LF
Description	Power Connector 8W8 Socket
Other features	mates with DC8W8PA00LF

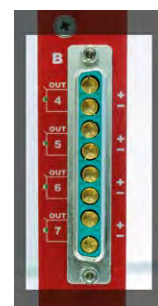

D-Sub26

n. 12

Factory Name	FCI ICD26S13E4GV00LF
Description	Connector High Density D-Sub SKT 26 POS 2.28mm Solder RA Thru-Hole 26 Terminal Port
Other features	-



Front-end Connectors

Robinson Nugent 68 pin boardmount connector n. 11

Factory Name	3M P50E-068P1-SR1
Description	Robinson Nugent 68 pin straight angle thru-hole boardmount connector
Other features	Mates with: 3M P25E-068S (SY2791) 3M P50E-068S (other modules)



Header-type connectors n. 12

Factory Name	3M 3431-6202 (17+17 pin); 3M 3408-5202 (8+8 16 pin)
Description	Header-type connector
Other features	Available with different pin sets; the 17+17 connector mates with 3M 3414-6600 wiremount connector

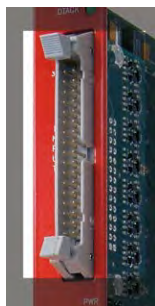

LEMO n. 13

Factory Name	Fischer DP101A004-51
Description	LEMO type coaxial connector
Other features	-



BNC n. 14

Factory Name	Radiall R141603
Description	BNC type coaxial connector
Other features	-



Strip Header n. 15

Factory Name	AMP 5/826634/0 (17+17 pin)
Description	Male strip header (17+17 pin)
Other features	the 17+17 connector mates with 3M 3414-6600 wiremount connector



USB n. 16

Factory Name	AMP 787780-2
Description	USB Type B
Other features	-



LC n. 17

Factory Name	Agilent HFBR-5911L/AL
Description	LC type duplex connector
Other features	-



LEMO EPG0B n. 18

Factory Name	EPG.0B.302.HLN
Description	LEMO 2 pin type
Other features	-



MCX connector n. 19

Factory Name	SUHNER CS 85MCX-50-0-16
Description	50 Ω MCX connector
Other features	-



SMC 68 pin connector n. 20

Factory Name	ERNI SMC-114805
Description	Dual Row 68 pin connectors
Other features	-



AMP 3 pin connector n. 21

Factory Name	AMP 3-102203-4
Description	3 pin connector
Other features	-



SMA n. 22

Factory Name	Johnson 142-0701-871
Description	SMA 50 Ohm connector
Other features	-

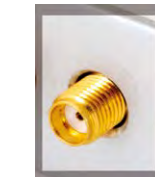

+12V connector n. 23

Factory Name	RAPC722X SWITCHCRAFT
Description	PCB DC Power Jack
Other features	-



Front-end Connectors

Mini USB

n. 24



<i>Factory name</i>	MOLEX SD-54819-026
<i>Description</i>	USB Mini type
<i>Other features</i>	-

VHDCI

n. 25

<i>Factory name</i>	MOLEX 71430-0008
<i>Description</i>	0.80mm Pitch VHDCI Receptacle, 68 Circuits
<i>Other features</i>	-





**Cross
Reference
Tables**

Cross Reference Tables Index

Universal Multichannel Systems- Mainframes	T1 / p. 218	Charge Sensitive Preamplifiers (Scintillation Detectors)	T16 / p. 224
Universal Multichannel Systems - Individual Floating Channel Boards .	T2 / p. 218	Fast Preamplifiers	T17 / p. 224
Universal Multichannel Systems - Common Ground Boards	T3 / p. 219	Coincidence/Logic/Trigger Units	T18 / p. 225
Universal Multichannel Systems - Common Floating Return Boards	T4 / p. 219	Controllers	T19 / p. 225
VME High Voltage Power Supplies	T5 / p. 220	Discriminators	T20 / p. 225
NIM High Voltage Power Supplies	T6 / p. 220	Fan In-Fan Out Units	T21 / p. 225
Desktop High Voltage Power Supplies	T7 / p. 221	I/O Registers	T22 / p. 226
PCB High Voltage Power Supplies	T8 / p. 221	QDCs	T23 / p. 226
Powered Crates	T9 / p. 222	Scalers	T24 / p. 226
ADCs (Peak Sensing)	T10 / p. 222	TDCs	T25 / p. 226
Digitizers	T11 / p. 223	Timing Units	T26 / p. 227
Amplifiers (Fast)	T12 / p. 223	Translators	T27 / p. 227
Amplifiers (Spectroscopy)	T13 / p. 224	Desktop/Portable Digital MCAs.....	T28 / p. 227
Attenuators	T14 / p. 224	NIM Digital MCAs	T29 / p. 228
Charge Sensitive Preamplifiers	T15 / p. 224		

■ colour red = new product ■ colour green = coming soon product

Universal Multichannel Systems - Mainframes

T1

Model	Max power (W)	Power requirements	Width	Height	Depth	Supported boards	Max # boards	Local control	Remote control	p.
SY4527	4200 @ 220 Vac 1990 @ 110 Vac	100 ÷ 240 Vac / 50 ÷ 60 Hz Max Power: 5500 W @ 220 Vac 2750 W @ 110 Vac	19"	8U	75 cm (with handles)	A15xx, A18xx, A19xx, A251x, A29xx, AG5xx, AG9xx, AP932, AG7xxx, A7xxx, A1676A	16	10.4" or 5.7" touchscreen color LCD (opt.)	Gb Ethernet, Wi-Fi (opt.)	16
SY5527	1800 @ 220 Vac 1850 @ 110 Vac	100 ÷ 240 Vac / 50 ÷ 60 Hz Max Power: 2500 W @ 220 Vac 2340 W @ 110 Vac	19"	4U	75 cm (with handles)	A15xx, A18xx, A19xx, A251xx , A29xx, AG5xx, AG9xx, AP932, AG70xx, A70xx, A1676A	6	5.7" touchscreen color LCD (opt.)	Gb Ethernet, Wi-Fi (opt.)	16
SY4527LC	600 @ 220 Vac 550 @ 110 Vac	100 ÷ 240 Vac / 50 ÷ 60 Hz Max Power: 1050 W @ 220 Vac 1020 W @ 110 Vac	19"	8U	56 cm (with handles)	A15xx, A18xx, A19xx, A251xx , A29xx, AG5xx, AG9xx, AP932, AG70xx, A70xx, A1676A	10	No	Gb Ethernet, Wi-Fi (opt.)	20
SY5527LC	400 @ 220 Vac 350 @ 110 Vac	100 ÷ 240 Vac / 50 ÷ 60 Hz Max Power: 700 W @ 220 Vac 660 W @ 110 Vac	19"	4U	49 cm (with handles)	A15xx, A18xx, A19xx, A251xx , A29xx, AG5xx, AG9xx, AP932, AG70xx, A70xx, A1676A	4	No	Gb Ethernet, Wi-Fi (opt.)	20
SY8800	2500 @ 220 Vac 1500 @ 110 Vac	3300 @ 220 Vac 2000 @ 115 Vac	19"	3 U	35 cm	Mx1, Bx1, Bx2	6	OLED display Ergonomic Pointer	RS232, Ethernet CAN bus, USB 2.0	70

Universal Multichannel Systems - Individual Floating Channel Boards

T2

Model	No. of Channels	Max Output V	Max Output I	Vset/Vmon Resolution	Iset/Imon Resolution	Max. Ramp Up/Down Rate	Ripple Typ.	Connectors	Max Power per Channel	p.
A1510	12	100 V	10 / 1 mA selectable	20 mV	1 / 0.1 µA	50 V/s	< 15 mVpp	DB37	1 W	32
A1511B	12	500 V	10 / 1 mA selectable	100 mV	1 / 0.1 µA	50 V/s	< 30 mVpp	DB37	5 W	32
A1512	12	500 V	1 / 0.1 mA selectable	100 mV	100 / 10 nA	50 V/s	< 30 mVpp	DB37	0.5 W	32
A1513B	6	10 V	2.7 A	10 mV	10 mA	19 V/s	< 5 mVpp	DB37	27 W	27
A1516B	6	15 V	1.5 A	10 mV	10 mA	29 V/s	< 5 mVpp	DB37	23 W	27
A1517B	6	7 V	4 A	10 mV	10 mA	14 V/s	< 5 mVpp	DB37	28 W	27
A1518B	6	4.5 V	6 A	10 mV	10 mA	9 V/s	< 5 mVpp	DB37	27 W	27
A1519B	12	250 V	1 / 0.1 mA selectable	50 mV	100 / 10 nA	50 V/s	< 30 mVpp	DB37	0.25 W	32
A1520P	12	+ 500 V	15 mA	1 mV	250 / 25 nA	50 V/s	< 20 mVpp	AMP75	7.5 W	32
A1515	16	1000 V	1 / 0.1 mA selectable	20 mV	Iset: 20 nA Imon: 1 / 0.1 nA	100 V/s	< 10 mVpp (CM) < 5 mVpp (DM)	Radial Multipin	0.8 W	37
A1515TG	14	1000 V	1 / 0.1 mA selectable	20 mV	Iset: 20 nA Imon: 1 / 0.1 nA	100 V/s	< 10 mVpp (CM) < 5 mVpp (DM)	Radial Multipin	0.8 W	37
A1515QG	16	1000 V	1 / 0.1 mA selectable	20 mV	Iset: 20 nA Imon: 1 / 0.1 nA	100 V/s	< 10 mVpp (CM) < 5 mVpp (DM)	Radial Multipin	0.8 W	37
A1534	6	8000 V	200 µA	500 mV	20 nA	500 V/s	< 50 mVpp	CPE 3 pole	1.6 W	39
A2517	8	5 V	15 A	1 mV	10 / 1 mA	1 ms (min. ramp time)	< 10 mVpp	D-Sub 8W8, DB37	50 W	27
A2518	8	8 V	10 A	1 mV	10 / 1 mA	1 ms (min. ramp time)	< 10 mVpp	D-Sub 8W8, DB37	50 W	27
A2519	8	15 V	5 A	1 mV	10 / 1 mA	1 ms (min. ramp time)	< 10 mVpp	D-Sub 8W8, DB37	50 W	27
AP932	1	3000 V	30 mA	100 mV	1 µA	500 V/s	< 30 mVpp	SHV	90 W	33

All specifications guaranteed from 10% to 90% of FSR.

Universal Multichannel Systems - Common Ground Boards

T3

Model	No. of Channels	Max Output V	Max Output I	Vset/Vmon Resolution	Iset/Imon Resolution	Max. Ramp Up/Down Rate	Ripple Typ.	Connectors	Max Power per Channel	p.
A1821	12	3000 V	0.2, 0.02 mA selectable	250 mV	20 / 2 nA	500 V/s	< 30 mVpp	SHV	0.6 W	33
A1821H	12	3000 V	0.2, 0.01 mA selectable	250 mV	20 / 1 nA	500 V/s	< 30 mVpp	SHV	0.6 W	33
A1833	12	3000, 4000 V selectable	3, 2, 0.2 mA selectable	250 mV	200 / 20 nA	500 V/s	< 30 mVpp	SHV	9 / 8 W	33
AG523	6	12000 V	1 mA	1000 mV	100 nA	500 V/s	< 30 mVpp	CPE HV	12 W	42
AG524	6	12000 V	0.1 mA	1000 mV	10 nA	500 V/s	< 20 mVpp	CPE HV	1.2 W	42
AG535 ⁽¹⁾	12 / 24	3500 V	3 mA	500 mV	500 nA	500 V/s	< 20 mVpp	SHV / Radial 52	8 W	33
AG536 ⁽¹⁾	12 / 24 / 32	3000 V	1 mA	100 mV	50 nA	500 V/s	< 10 mVpp	SHV / Radial 52	3 W	33
AG538D	12	1500 V	10 mA	50 mV	200 nA	500 V/s	< 20 mVpp	SHV	12 W	33
AG539 ⁽¹⁾	12 / 24 / 32	100 V	10 mA	10 / 1 mV	10 / 1 nA	50 V/s	< 5 mVpp	SHV / Radial 52	1 W	28
AG540 ⁽¹⁾	12 / 24 / 32	100 V	1 mA	10 / 1 mV	10 / 1 nA	50 V/s	< 3 mVpp	SHV / Radial 52	0.1 W	28
AG541 ⁽¹⁾	12 / 24 / 32	500 V	10 mA	10 / 1 mV	10 / 1 nA	100 V/s	< 5 mVpp	SHV / Radial 52	5 W	28
AG542 ⁽¹⁾	12 / 24 / 32	500 V	1 mA	10 / 1 mV	10 / 1 nA	100 V/s	< 3 mVpp	SHV / Radial 52	0.5 W	28
AG550 ⁽¹⁾	12 / 24 / 32	5000 V	1 mA	500 mV	100 nA	500 V/s	< 25 mVpp	SHV / Radial 52	5 W (1.5 W if 32 channels)	39
AG590	16	9000 V	50 µA	200 / 10 mV	1 nA / 100 pA	500 V/s	< 10 mVpp	Radial 52	0.45 W	42
AG7030	12/24/36/48	3000 V	1 mA	50 / 10 mV	20 / 2 nA	500 V/s	< 5 mVpp	SHV / Radial 52	1.5 W	36
AG7040	48	100 V	500 µA	2 / 0.2 mV	10 / 1 nA	50 V/s	< 5 mVpp	Radial 52	50 mW	31
AG7042	48	500 V	500 µA	10 / 1 mV	10 / 1 nA	100 V/s	< 5 mVpp	Radial 52	250 mW	31
AG7236	32	3500 V	1.5 mA, 150 µA selectable	5 mV	10 / 5 nA	500 V/s	< 10 mVpp	Radial 52	4 W	38
AG7435	24	3500 V	3.5 mA, 350 µA selectable	5 mV	10 nA	500 V/s	< 15 mVpp	Radial 52	9 W	38

All specifications guaranteed from 10% to 90% of FSR.

(1) Available with positive, negative or mixed polarity.

Universal Multichannel Systems - Common Floating Return Boards

T4

Model	No. of Channels	Max Output V	Max Output I	Vset/Vmon Resolution	Iset/Imon Resolution	Max. Ramp Up/Down Rate	Ripple Typ.	Connectors	Max Power per Channel	p.
A1523	6	12000 V	1 mA	1000 mV	100 nA	500 V/s	< 30 mVpp	CPE HV	12 W	42
A1524	6	12000 V	0.1 mA	1000 mV	10 nA	500 V/s	< 20 mVpp	CPE HV	1.2 W	42
A1526	6	15000 V	1 / 0.1 mA selectable	1000 mV	100 / 10 nA	500 V/s	< 30 mVpp	CPE HV	15 W	44
A1535 ⁽¹⁾	12 / 24	3500 V	3 mA	500 mV	500 nA	500 V/s	< 20 mVpp	SHV / Radial 52	8 W	33
A1536 ⁽¹⁾	12 / 24 / 32	3000 V	1 mA	100 mV	50 nA	500 V/s	< 10 mVpp	SHV / Radial 52	3 W	33
A1538D	12	1500 V	10 mA	50 mV	200 nA	500 V/s	< 20 mVpp	SHV	12 W	33
A1539 ⁽¹⁾	12 / 24 / 32	100 V	10 mA	10 / 1 mV	10 nA / 1 nA	50 V/s	< 5 mVpp	SHV / Radial 52	1.5 W	28
A1540 ⁽¹⁾	12 / 24 / 32	100 V	1 mA	10 / 1 mV	10 nA / 1 nA	50 V/s	< 3 mVpp	SHV / Radial 52	0.1 W	28
A1540H ⁽¹⁾	12 / 24 / 32	100 V	1 mA / 100 µA selectable	10 / 1 mV	Iset: 20 nA Imon: 1 / 0.1 nA	50 V/s	< 3 mVpp	SHV / Radial 52	0.1 W	28
A1541 ⁽¹⁾	12 / 24 / 32	500 V	10 mA	10 / 1 mV	10 nA / 1 nA	100 V/s	< 5 mVpp	SHV / Radial 52	5 W	28
A1542 ⁽¹⁾	12 / 24 / 32	500 V	1 mA	10 / 1 mV	10 nA / 1 nA	100 V/s	< 3 mVpp	SHV / Radial 52	0.5 W	28
A1542H ⁽¹⁾	12 / 24 / 32	500 V	1 mA / 100 µA selectable	10 / 1 mV	Iset: 20 nA Imon: 1 / 0.1 nA	100 V/s	< 3 mVpp	SHV / Radial 52	0.5 W	28
A1550 ⁽¹⁾	12 / 24	5000 V	1 mA	500 mV	100 nA	500 V/s	< 25 mVpp	SHV / Radial 52	5 W	39
A1560H ⁽¹⁾	8 / 16	6000 V	20 µA	100 / 10 mV	500 / 50 pA	500 V/s	< 5 mVpp	SHV / Radial 52	120 mW	41
A1561H	12	6000 V	20 µA	100 / 10 mV	500 / 50 pA	500 V/s	< 5 mVpp	SHV	120 mW	39
A1580H	8 / 16	8000 V	20 µA	200 / 10 mV	500 / 50 pA	500 V/s	< 5 mVpp	SHV / Radial 52	160 mW	41
A1590	16	9000 V	50 µA	200 / 10 mV	1 nA / 100 pA	500 V/s	< 10 mVpp	Radial 52	0.45 W	42
A7030	12/24/36/48	3000 V	1 mA	50 / 10 mV	20 / 2 nA	500 V/s	< 5 mVpp	SHV / Radial 52	1.5 W	36
A7040	48	100 V	500 µA	2 / 0.2 mV	10 / 1 nA	50 V/s	< 5 mVpp	Radial 52	50 mW	31
A7042	48	500 V	500 µA	10 / 1 mV	10 / 1 nA	100 V/s	< 5 mVpp	Radial 52	250 mW	31
A7236	32	3500 V	1.5 mA, 150 µA selectable	5 mV	10 / 5 nA	500 V/s	< 10 mVpp	Radial 52	4 W	38
A7435	24	3500 V	3.5 mA, 350 µA selectable	5 mV	10 nA	500 V/s	< 15 mVpp	Radial 52	9 W	38

All specifications guaranteed from 10% to 90% of FSR.

(1) Available with positive, negative or mixed polarity.

VME High Voltage Power Supplies

Model	No. of Channels	Max Output V	Max Output I	Vset/Vmon Resolution	Iset/Imon Resolution	Max. Ramp Up/Down Rate	Ripple Typ.	Connectors	Max Power per Channel	Features	p.
V6519	6	500 V	3 mA	10 mV	Iset: 50 nA Imon: 50 / 5 nA ⁽¹⁾	100 V/s	< 3 mVpp	SHV	1.5 W	Common Floating Return	56
V6521	6	6000 V	300 μ A	0.1 V	Iset: 5 nA Imon: 5 / 0.5 nA ⁽¹⁾	500 V/s	< 3 mVpp	SHV	1.8 W	Common Floating Return	56
V6521H	6	6000 V	20 μ A	0.1 V	Iset: 1 nA Imon: 1 / 0.1 nA ⁽¹⁾	500 V/s	< 3 mVpp	SHV	0.12 W	Common Floating Return	56
V6533	6	4000 V	3 mA	0.1 V	Iset: 50 nA Imon: 50 / 5 nA ⁽¹⁾	500 V/s	< 12 mVpp	SHV	9 W	Common Floating Return	56
V6534	6	6000 V	1 mA	0.1 V	Iset: 20 nA Imon: 20 / 2 nA ⁽¹⁾	500 V/s	< 15 mVpp	SHV	6 W	Common Floating Return	56

All specifications guaranteed from 10% to 90% of FSR. All Modules are available with positive, negative or mixed polarity.

(1) Optional Imon zoom.

NIM High Voltage Power Supplies

Model	No. of Channels	Max Output V	Max Output I	Vset/Vmon Resolution	Iset/Imon Resolution	Max. Ramp Up/Down Rate	Ripple Typ.	Connectors	Max Power per Channel	Features	p.
N1470	4	\pm 8000 V	3 mA	0.2 V	Iset: 50 nA Imon: 50 / 5 nA ⁽¹⁾	500 V/s	< 5 - 15 mVpp	SHV	9 W (< 3 kV) 8 W (> 3 kV)	Common Floating Return	58
N1470A / B	2 / 1	\pm 8000 V	3 mA	0.2 V	Iset: 50 nA Imon: 50 / 5 nA ⁽¹⁾	500 V/s	< 5 - 15 mVpp	SHV	9 W (< 3 kV) 8 W (> 3 kV)	Common Floating Return	58
N1470AL	2	\pm 8000 V	3 mA	0.2 V	Iset: 50 nA Imon: 50 / 5 nA ⁽¹⁾	500 V/s	< 5 - 15 mVpp	SHV	9 W (< 3 kV) 8 W (> 3 kV)	Common Floating Return Local control only	58
N1470AR	2	\pm 8000 V	3 mA	0.2 V	Iset: 50 nA Imon: 50 / 5 nA ⁽¹⁾	500 V/s	< 5 - 15 mVpp	SHV	9 W (< 3 kV) 8 W (> 3 kV)	Common Floating Return Remote control only	58
N1470ET	4	\pm 8000 V	3 mA	0.2 V	Iset: 50 nA Imon: 50 / 5 nA ⁽¹⁾	500 V/s	< 5 - 15 mVpp	SHV	9 W (< 3 kV) 8 W (> 3 kV)	Common Floating Return	58
NDT1470	4	\pm 8000 V	3 mA	0.2 V	Iset: 50 nA Imon: 50 / 5 nA ⁽¹⁾	500 V/s	< 5 - 15 mVpp	SHV	9 W (< 3 kV) 8 W (> 3 kV)	Common Floating Return NIM/Desktop	58
N1471	4	\pm 5500 V	0.3 mA	0.1 V	Iset: 5 nA Imon: 5 / 0.5 nA ⁽¹⁾	500 V/s	< 5 mVpp	SHV	1.65 W	Common Floating Return	58
N1471A / B	2 / 1	\pm 5500 V	0.3 mA	0.1 V	Iset: 5 nA Imon: 5 / 0.5 nA ⁽¹⁾	500 V/s	< 5 mVpp	SHV	1.65 W	Common Floating Return	58
N1471ET	4	\pm 5500 V	0.3 mA	0.1 V	Iset: 5 nA Imon: 5 / 0.5 nA ⁽¹⁾	500 V/s	< 5 mVpp	SHV	1.65 W	Common Floating Return	58
NDT1471	4	\pm 5500 V	0.3 mA	0.1 V	Iset: 5 nA Imon: 5 / 0.5 nA ⁽¹⁾	500 V/s	< 5 mVpp	SHV	1.65 W	Common Floating Return NIM/Desktop	58
N1471H	4	\pm 5500 V	0.02 mA	0.1 V	Iset: 5 nA Imon: 5 / 0.05 nA ⁽¹⁾	500 V/s	< 5 mVpp	SHV	0.1 W	Common Floating Return	58
N1471HA / B	2 / 1	\pm 5500 V	0.02 mA	0.1 V	Iset: 5 nA Imon: 5 / 0.05 nA ⁽¹⁾	500 V/s	< 5 mVpp	SHV	0.1 W	Common Floating Return	58
N1471HET	4	\pm 5500 V	0.02 mA	0.1 V	Iset: 5 nA Imon: 5 / 0.05 nA ⁽¹⁾	500 V/s	< 5 mVpp	SHV	0.1 W	Common Floating Return	58
NDT1471H	4	\pm 5500 V	0.02 mA	0.1 V	Iset: 5 nA Imon: 5 / 0.05 nA ⁽¹⁾	500 V/s	< 5 mVpp	SHV	0.1 W	Common Floating Return NIM/Desktop	58
N1419	4	\pm 500 V	0.2 mA	0.01 V	Iset: 5 nA Imon: 5 / 0.5 nA ⁽¹⁾	100 V/s	< 3 mVpp	SHV	0.1 W	Common Floating Return	58
N1419A / B	2 / 1	\pm 500 V	0.2 mA	0.01 V	Iset: 5 nA Imon: 5 / 0.5 nA ⁽¹⁾	100 V/s	< 3 mVpp	SHV	0.1 W	Common Floating Return	58
N1419ET	4	\pm 500 V	0.2 mA	0.01 V	Iset: 5 nA Imon: 5 / 0.5 nA ⁽¹⁾	100 V/s	< 3 mVpp	SHV	0.1 W	Common Floating Return	58
NDT1419	1	\pm 500 V	0.2 mA	0.01 V	Iset: 5 nA Imon: 5 / 0.5 nA ⁽¹⁾	100 V/s	< 3 mVpp	SHV	0.1 W	Common Floating Return NIM/Desktop	58
N472	4	\pm 3 / 6 kV	3 / 1 mA	analog setting	analog setting	1000 V/s (fixed)	< 30 mVpp @ 3 kV < 80 mVpp @ 6 kV	SHV	9 W @ 3 kV 6 W @ 6 kV	NIM/Desktop	52
N1570	2	\pm 15000 V	1 mA	0.5 V	Iset: 20 nA Imon: 20 / 2 nA ⁽¹⁾	500 V/s	tbd	HV LEMO	10 W	Common Floating Return	53

All specifications guaranteed from 10% to 90% of FSR.

(1) Imon zoom.

Desktop High Voltage Power Supplies

T7

Model	No. of Channels	Max Output V	Max Output I	Vset/Vmon Resolution	Iset/Imon Resolution	Max. Ramp Up/Down Rate	Ripple Typ.	Connectors	Max Power per Channel	Features	p.
DT5519E	4	500 V	3 mA	Vset: 10 mV Vmon: 1 mV	Iset: 50 nA Imon: 10 / 1 nA ⁽¹⁾	100 V/s	< 3 mVpp	SHV	1.5 W	Remote control via USB or Ethernet	56
DT5521E	4	6000 V	300 µA	Vset: 100 mV Vmon: 50 mV	Iset: 5 nA Imon: 1 / 0.1 nA ⁽¹⁾	500 V/s	< 3 mVpp	SHV	1.8 W	Remote control via USB or Ethernet	56
DT5521HE	4	6000 V	20 µA	Vset: 100 mV Vmon: 50 mV	Iset: 0.5 nA Imon: 0.1 / 0.01 nA ⁽¹⁾	500 V/s	< 3 mVpp	SHV	0.12 W	Remote control via USB or Ethernet	56
DT5533E	4	4000 V	3 mA	Vset: 100 mV Vmon: 10 mV	Iset: 50 nA Imon: 10 / 1 nA ⁽¹⁾	500 V/s	< 12 mVpp	SHV	4 W	Remote control via USB or Ethernet	56
DT5534E	4	6000 V	1 mA	Vset: 100 mV Vmon: 50 mV	Iset: 20 nA Imon: 5 / 0.5 nA ⁽¹⁾	500 V/s	< 15 mVpp	SHV	4 W	Remote control via USB or Ethernet	56
DT1419ET	4	±500 V	200 µA	10 mV	Iset: 5 nA Imon: 5 / 0.5 nA ⁽¹⁾	100 V/s	< 3 mVpp	SHV	0.1 W	Remote control via USB or Ethernet	58
DT1471ET	4	±5500 V	300 µA	100 mV	Iset: 5 nA Imon: 5 / 0.5 nA ⁽¹⁾	500 V/s	< 5 mVpp	SHV	1.65 W	Remote control via USB or Ethernet	58
DT1471HET	4	±5500 V	20 µA	100 mV	Iset: 1 nA Imon: 1 / 0.05 nA ⁽¹⁾	500 V/s	< 5 mVpp	SHV	0.1 W	Remote control via USB or Ethernet	58
DT1470ET	4	±8000 V	3 mA	200 mV	Iset: 50 nA Imon: 50 / 5 nA ⁽¹⁾	500 V/s	< 5 - 15 mVpp	SHV	9 W (< 3 kV) 8 W (> 3 kV)	Remote control via USB or Ethernet	58
R1419ET	4 / 8	±500 V	200 µA	10 mV	Iset: 5 nA Imon: 5 / 0.5 nA ⁽¹⁾	100 V/s	< 3 mVpp	SHV	0.1 W	Remote control via USB or Ethernet	61
R1471ET	4 / 8	±5500 V	300 µA	100 mV	Iset: 5 nA Imon: 5 / 0.5 nA ⁽¹⁾	500 V/s	< 5 mVpp	SHV	1.65 W	Remote control via USB or Ethernet	61
R1471HET	4 / 8	±5500 V	20 µA	100 mV	Iset: 1 nA Imon: 1 / 0.05 nA ⁽¹⁾	500 V/s	< 5 mVpp	SHV	0.1 W	Remote control via USB or Ethernet	61
R1470ET	4 / 8	±8000 V	3 mA	200 mV	Iset: 50 nA Imon: 50 / 5 nA ⁽¹⁾	500 V/s	< 5 - 15 mVpp	SHV	9 W (< 3 kV) 8 W (> 3 kV)	Remote control via USB or Ethernet	61
DT5470	1	5000 V	200 µA	1 V	Iset: 40 nA Imon: 4 / 0.4 nA ⁽¹⁾	500 V/s	< 10 mVpp	SHV	1 W	Powered and controlled by USB	59
DT5471	1	3000 V	500 µA	500 mV	Iset: 100 nA Imon: 10 / 1 nA ⁽¹⁾	500 V/s	< 10 mVpp	SHV	1 W	Powered and controlled by USB	59
DT5472	1	500 V	1 mA	100 mV	Iset: 200 nA Imon: 20 / 2 nA ⁽¹⁾	100 V/s	< 10 mVpp	SHV	0.5 W	Powered and controlled by USB	59

All specifications guaranteed from 10% to 90% of FSR.

DT55xxE: available with positive, negative or mixed polarity. DT14xxET and R14xxET: channel polarity independently selectable.

(1) Imon zoom.

PCB High Voltage Power Supplies

T8

Model	No. of Channels	Max Output V	Max Output I	Vset Input (V)	Vmon Output (V)	Imon Output (V)	Ripple Typ.	Power requirement (mW)	Operating temperature	p.
A7501	1	2100 V	100 µA	0 ÷ +2.5	0 ÷ +5	0 ÷ +2.5	< 5 mVpp	< 400	-40 °C ÷ +70 °C	62
A7504	1	4000 V	100 µA	0 ÷ +2.6	0 ÷ +2.5	0 ÷ +2.5	< 10 mVpp	< 600	-10 °C ÷ +50 °C	62
A7505	1	1600 V	500 µA	0 ÷ +2.6	0 ÷ +2.6	0 ÷ +2.5	< 5 mVpp	< 1600	-55 °C ÷ +80 °C	62
A7508	1	800 V	50 µA	0 ÷ +2.5	0 ÷ +2.5	0 ÷ +2.5	< 5 mVpp	< 100	-40 °C ÷ +70 °C	62
A7560	1	±6000 V	10 µA	0 ÷ +2	0 ÷ +2	0 ÷ +2	< 10 mVpp	< 2000	-10 °C ÷ +50 °C	63

All specifications guaranteed from 10% to 90% of FSR.

Powered Crates

T9

Model	Package	No. of Slots	Width	Height	Backplane connectors	Pluggable power supplies	Pluggable fan unit	Remote control	Output power	p.
NIM8301	NIM	12	19"	7U	NIM	Yes	Yes	RS232, USB (2.0), CANBUS, Ethernet	300 W / 600 W	166
NIM8302	NIM Compact	10	19"	5U	NIM	Yes	No fan unit	No	150 W	170
NIM8302P	NIM Portable	7	270 mm	5U	NIM	Yes	No fan unit	No	150 W	170
NIM8303	NIM	12	19"	5U	NIM	Yes	No fan unit	No	300 W / 600 W	168
NIM8304	NIM	12	19"	7U	NIM	Yes	Yes	RS232, USB (2.0), CANBUS, Ethernet	1100 W @ 110 Vac 2200 W @ 220 Vac	172
NIM8305	NIM Mini	2	170 mm	124 mm	NIM	No	No	No	430 W	171
NIM8306	NIM Mini	2	170 mm	124 mm	NIM	No	No	No	720 W	171
NV8020A	NIM / VME64	NIM: 5 VME: 8	19"	7U	NIM / VME64 J1/J2	NIM: Yes VME: No	No	No	NIM: 150 W VME: 365 W	174
VME8001	VME64	2 (6U)	19"	1U	VME64 J1/J2	No	No	No	170 W	163
VME8004B	VME64	4 (6U)	19"	2U	VME64 J1/J2	No	No	No	365 W	163
VME8004X	VME64X	4 (6U)	19"	4U	VME64X J1/J0/J2	No	No	No	450 W	164
VME8008B	VME64	8 (6U)	19"	4U	VME64 J1/J2	No	No	No	490 W	164
VME8008X	VME64X	8 (6U)	19"	4U	VME64X J1/J0/J2	No	No	No	450 W	165
VME8010	VME64	21 (6U)	19"	7U	VME64 J1/J2	No	No	No	470 W	162
VME8011	VME64	21 (6U)	19"	7U	VME64 J1/J2	Yes	No	No	470 W	162
VME8100	VME64, VME64X	21 (6U)	19"	8U	VME64 J1/J2, VME64X J1/J2, VME64X J1/J0/J2	Yes	Yes	RS232, USB (2.0), CANBUS, Ethernet	1200 W @ 100 Vac 2530 W @ 211 Vac	158
VME8200	VME64X	21 (6U), 21 Rear	19"	9U: (8U + 1U Air Filter)	VME64X J1/J0/J2	Yes	Yes	RS232, USB (2.0), CANBUS, Ethernet	1200 W @ 100 Vac 2530 W @ 211 Vac	160

ADCs (Peak Sensing)

T10

Model	Package	No. of Channels	Resolution (bits)	Conversion Time (μs)	LSB (mV)	Full Scale Range (V)	Multi Event Buffer size	Fast Clear (ns)	Connectors	p.
N957	NIM	1	13	1.2	1	10	64 K events	600	LEMO	122
V1785	VME	8	12	2.8	1 / 0.125 (Dual)	4 / 0.5 (Dual)	32 events	600	LEMO	134
V785	VME	32	12	5.7	1 / 2	4 / 8	32 events	600	Std. Flat	134
V785N	VME	16	12	2.8	1	4	32 events	600	LEMO	134

Digitizers

T11

Model	Package	No. of Channels	Max Sampling Rate (MS/s)	Bandwidth (MHz)	Full Scale Range (V)	Resolution (bits)	LSB (μ V)	Board Memory (Samples/ch)	Analog Input Connectors	p.
DT5720	Desktop	4 / 2	250	125	2	12	500	1.25 M / 10 M	MCX	90
DT5724	Desktop	4 / 2	100	40	0.5 / 2.25 / 10	14	30 / 140 / 600	512 k / 4 M	MCX	92
DT5725	Desktop	8	250	125	0.5 - 2	14	30 - 120	640 k / 5.12 M	MCX	94
DT5730	Desktop	8	500	250	0.5 - 2	14	30 - 120	640 k / 5.12 M	MCX	96
DT5740	Desktop	32 - 16 ⁽⁴⁾	62.5	30	2 / 10	12	500 / 2500	192 k	SMC 68P - MCX	98
DT5742 ⁽²⁾	Desktop	16 + 1	5000 ⁽³⁾	500	1	12	250	128 / 1024 events ⁽⁶⁾	MCX	104
DT5743 ⁽¹⁾	Desktop	8	3200	500	2.5	12	600	7 events ⁽⁶⁾	MCX	106
DT5751	Desktop	2 ⁽⁵⁾ - 4	2000 ⁽⁵⁾ - 1000	500	0.2 / 1	10	200 / 1000	3.6 M ⁽⁵⁾ - 1.8 M	MCX	100
DT5761	Desktop	1	4000	1000	1	10	1000	7.2 M	MCX	102
N6720	NIM	4 / 2	250	125	2	12	500	1.25 M / 10 M	MCX	90
N6724	NIM	4 / 2	100	40	0.5 / 2.25 / 10	14	30 / 140 / 600	512 k	MCX	92
N6725	NIM	8	250	125	0.5 - 2	14	30 - 120	640 k / 5.12 M	MCX	94
N6730	NIM	8	500	250	0.5 - 2	14	30 - 120	640 k / 5.12 M	MCX	96
N6740	NIM	32	62.5	30	2 / 10	12	500 / 2500	192 k	SMC 68P	98
N6742 ⁽²⁾	NIM	16 + 1	5000 ⁽³⁾	500	1	12	250	128 / 1024 events ⁽⁶⁾	MCX	104
N6743 ⁽¹⁾	NIM	8	3200	500	2.5	12	600	7 events ⁽⁶⁾	MCX	106
N6751	NIM	2 ⁽⁵⁾ - 4	2000 ⁽⁵⁾ - 1000	500	0.2 / 1	10	200 / 1000	3.6 M ⁽⁵⁾ - 1.8 M / 28.8 M ⁽⁵⁾ - 14.4 M	MCX	100
N6761	NIM	1	4000	1000	1	10	1000	7.2 M	MCX	102
V1720	VME	8	250	125	2	12	500	1.25 M / 10 M	MCX	90
V1724	VME	8	100	40	0.5 / 2.25 / 10	14	30 / 140 / 600	512 k / 4 M	MCX	92
V1725	VME	8 / 16	250	125	0.5 - 2	14	30 - 120	640 k / 5.12 M	MCX	94
V1730	VME	8 / 16	500	250	0.5 - 2	14	30 - 120	640 k / 5.12 M	MCX	96
V1740	VME	64	62.5	30	2 / 10	12	500 / 2500	192 k / 1.5 M	SMC 68P	98
V1742 ⁽²⁾	VME	32 + 2	5000 ⁽³⁾	500	1	12	250	128 / 1024 events ⁽⁶⁾	MCX	104
V1743 ⁽¹⁾	VME	16	3200	500	2.5	12	600	7 events ⁽⁶⁾	MCX	106
V1751	VME	4 ⁽⁵⁾ - 8	2000 ⁽⁵⁾ - 1000	500	0.2 / 1	10	200 / 1000	3.6 M ⁽⁵⁾ - 1.8 M / 28.8 M ⁽⁵⁾ - 14.4 M	MCX	100
V1761	VME	2	4000	1000	1	10	1000	7.2 M / 57.6 M	MCX	102
VX1720	VME64X	8	250	125	2	12	500	1.25 M / 10 M	MCX	90
VX1724	VME64X	8	100	40	0.5 / 2.25 / 10	14	30 / 140 / 600	512 k / 4 M	MCX	92
VX1725	VME64X	8 / 16	250	125	0.5 - 2	14	30 - 120	640 k / 5.12 M	MCX	94
VX1730	VME64X	8 / 16	500	250	0.5 - 2	14	30 - 120	640 k / 5.12 M	MCX	96
VX1740	VME64X	64	62.5	30	2 / 10	12	500 / 2500	192 k / 1.5 M	SMC 68P	98
VX1742 ⁽²⁾	VME64X	32 + 2	5000 ⁽³⁾	500	1	12	250	128 / 1024 events ⁽⁶⁾	MCX	104
VX1743 ⁽¹⁾	VME64X	16	3200	500	2.5	12	600	7 events ⁽⁶⁾	MCX	106
VX1751	VME64X	4 ⁽⁵⁾ - 8	2000 ⁽⁵⁾ - 1000	500	0.2 / 1	10	200 / 1000	3.6 M ⁽⁵⁾ - 1.8 M / 28.8 M ⁽⁵⁾ - 14.4 M	MCX	100
VX1761	VME64X	2	4000	1000	1	10	1000	7.2 M / 57.6 M	MCX	102

(1) Based on SAMLONG chip: 3.2 GS/s Switched Capacitor Array, 2 channels with 1024 storage cells each. (4) 32 channels on SMC connector, 16 channels on MCX connectors.

(2) Based on DRS chip: 5 GS/s Switched Capacitor Array, 8+1 channels with 1024 storage cells each. (5) If operating in Dual Edge Sampling (DES) mode.

(3) Sampling frequency of the analog memory (switched capacitor array); A/D conversion takes place at lower speed (dead-time). (6) 1 event = 1 k samples.

Amplifiers (Fast)

T12

Model	Package	No. of Channels	Gain	Bandwidth (MHz) ⁽¹⁾	Coupling	Input Impedance (Ω)	Output Rise Time (ns)	Output Range (V)	Equivalent Input Noise (μ V RMS)	In Conn.	Out Conn.	p.
N978	NIM	4	1 \div 10	250 (gain: 10x)	DC	50	< 1.5	\pm 2	< 50 (gain: 10x)	LEMO	LEMO	122
N979	NIM	16	10 (Optional in 2 \div 9 range)	250 (gain: 10x)	DC	50	< 1.5	\pm 2	< 50 (gain: 10x)	LEMO	LEMO	123
N979B	NIM	16	2, 4, 8, 10	250 (gain: 10x)	DC	50	< 1.5	\pm 2	< 50 (gain: 10x)	LEMO	LEMO	123
V974	VME	4	1 \div 10	170 (gain: 10x)	DC	50	< 3	\pm 2	< 70 (gain: 10x)	LEMO	LEMO	135
V975	VME	8	10	250	DC	50	< 1.5	\pm 2	< 50	LEMO	LEMO	135

(1) Bandwidth measured with ± 25 mV input signal.

Amplifiers (Spectroscopy)

T13

Model	Package	No. of Channels	Gain	Coupling	Shaping	Input Impedance (Ω)	Output Rise Time (ns)	Output Range (V)	Integral Non-linearity	Equivalent Input Noise (μ V RMS)	In Conn.	Out Conn.	p.
N1568A	NIM	16	0.8 ÷ 192	DC	Gaussian type	50	-	± 8 on 1 M Ω	< 0.005% ⁽²⁾	< 10	Strip Header	Strip Header	126
N568E	NIM	16	0.15 ÷ 480	DC	Gaussian type	50	25 ⁽¹⁾	± 8 on 1 M Ω	< 0.05%	< 15 (@gain=100)	LEMO	Strip Header	126
N568ELC	NIM	16	0.15 ÷ 480	DC	Gaussian type	50	25 ⁽¹⁾	± 8 on 1 M Ω	< 0.05%	< 25 (@gain=100)	LEMO	Strip Header	126
N568EB	NIM	16	0.15 ÷ 480	DC	Gaussian type	50	25 ⁽¹⁾	± 8 on 1 M Ω	< 0.05%	< 15 (@gain=100)	LEMO	Strip Header	126
N968	NIM	1	1 ÷ 3000	DC	semi-Gaussian	1000	-	10 on 1 M Ω	< 0.025%	< 3.5 (@gain=1000)	BNC	BNC	123
N1068	NIM	16	Coarse: 8 step Fine: 7-bit	DC	Gaussian type	50 (Single Ended) 110 (Differential)	-	± 8 on 1 M Ω	< 0.005% ⁽²⁾	< 10	LEMO / Strip Header	Strip Header	124

(1) Typical value on FAST_OUT.

(2) 20÷90% of the full scale @ Gain=Max and 4 μ s shaping time.

Attenuators

T14

Model	Package	No. of Channels	Range per Section (dB)	Resolution (dB)	Max Frequency (MHz)	I/O Delay (ns)	Insert Loss (dB)	I/O Connectors	p.
N858	NIM	2	0 ÷ 44.5	0.5	300	< 5	< 0.10	LEMO	127
V859	VME	2	0 ÷ 44.5	0.5	300	< 5	< 0.10	LEMO	135

Charge Sensitive Preamplifiers

T15

Model	Package	No. of Channels	Sensitivity (mV/MeV)	Equivalent Input Noise FWHM (keV)	Output Rise Time (ns)	Output Range (V)	Integral Non-linearity	Max Detector Bias Voltage (V)	Test Capacitance (pF)	In Conn.	Out Conn.	p.
A422A	Shielded box	1	5 / 30 / 60	< 17.5 @ 1 nF	< 50	± 8 ⁽²⁾ ± 4 ⁽¹⁾	< 0.045%	± 5000	10	SHV	BNC	150
A1422	Shielded box	1 / 4 / 8	5 / 45 / 90 / 400	< 6 @0pF ⁽⁴⁾ < 2 @0pF ⁽⁵⁾ < 10.6 @390pF ⁽⁶⁾ < 6.5 @390pF ⁽⁷⁾	< 10 @0pF ⁽⁸⁾ < 35 @0pF ⁽⁹⁾ < 20 @390pF ⁽⁶⁾ < 45 @390pF ⁽¹⁰⁾ < 100 @390pF ⁽¹¹⁾	± 3.5 ⁽¹⁾ ± 8 ⁽³⁾	< $\pm 0.05\%$ (0 ÷ ± 8 V peak output)	± 2000	1/10	SHV or BNC	LEMO or BNC	151
A1422H	15 pin SIP hybrid	1	5 / 45 / 90 / 400	< 6 @0pF ⁽⁴⁾ < 2 @0pF ⁽⁵⁾ < 10.6 @390pF ⁽⁶⁾ < 6.5 @390pF ⁽⁷⁾	< 10 @0pF ⁽⁸⁾ < 35 @0pF ⁽⁹⁾ < 20 @390pF ⁽⁶⁾ < 45 @390pF ⁽¹⁰⁾ < 100 @390pF ⁽¹¹⁾	± 3.5 ⁽¹⁾ ± 8 ⁽³⁾	< $\pm 0.05\%$ (0 ÷ ± 8 V peak output)	± 200	1/10	-	-	150

(1) Measured with 50 Ω termination; (2) Measured with 1 M Ω termination; (3) Measured with 1 k Ω termination; (4) F2 type, gain: 5 mV/MeV, (5) F2 type, gain: 45/90/400 mV/MeV, (6) F3 type, gain: 5 mV/MeV, (7) F3 type, gain: 45/90 mV/MeV; (8) F2 type, gain: 5/45/90 mV/MeV (9) F2 type, gain: 400 mV/MeV (10) F3 type, gain: 45 mV/MeV (11) F3 type, gain: 90 mV/MeV.

Charge Sensitive Preamplifiers (Scintillation Detectors)

T16

Model	Package	No. of Channels	Sensitivity (mV/pC)	Noise	Output Rise Time (ns)	Output Range (V)	Integral Non-linearity	Test Capacitance (pF)	In Conn.	Out Conn.	p.
A1424	Shielded box	1	0.8, 0.9, 1.1, 1.3, 1.5, 1.7, 2.5, 3, 5, 10 selectable	3.2 fC with 10 mV/pC sensitivity (max.); 8.5 fC with 0.8 mV/pC sensitivity (min.)	< 80 Energy Out < 3 Fast Out	± 8 ⁽¹⁾ ± 4 ⁽²⁾	< 0.02%	100	LEMO	LEMO	152

(1) Measured with 1 k Ω termination; (2) Measured with 50 Ω termination.

Fast Preamplifiers

T17

Model	Package	Inputs	Mode	Sensitivity (mV/fC)	Output Range (V)	Equivalent Input Noise RMS (fC)	Input Impedance (Ω)	Output Impedance (Ω)	Detector HV Rating (kV)	p.
A1425	Shielded box	1	Inverting	3.6	0 ÷ 1	0.21	200	50	1	152
A1426	Shielded box	1	Non-Inverting	5	0 ÷ 1	0.11	50	50	1	153

Coincidence/Logic/Trigger Units

T18

Model	Package	No. Of Sections	Function	Inputs per Section	Outputs per Section	I/O Delay (ns)	Input Bandwidth (MHz)	Majority	Strobe/Veto	Connectors	p.
N113	NIM	2	OR	12 NIM	2 NIM	< 10	130	No	Yes	LEMO	127
N405	NIM	3	Logic Unit	4 NIM	2+1 NIM, 1 NIM Linear	< 14	100	Yes	Yes	LEMO	127
N455	NIM	4	OR / AND	2 NIM	3+1 NIM, 1 NIM Overlap	< 16	130	No	Yes	LEMO	128
V2495	VME	1	Programmable Trigger Unit FPGA: Cyclone V 5CGXC4 (50 K LEs)	64 ECL/ PECL/ LVDS+2 bidirectional NIM/TTL (expandable up to 162)	32 LVDS+2 bidirectional NIM/TTL (expandable up to 130)	n/a	tbd	Yes	Yes	Robinson Nugent Flat/ LEMO	136
V976	VME	4	Logic Unit	4 NIM/TTL	4 NIM/TTL	< 9	150	Yes	No	LEMO	138

Controllers

T19

Model	Package	Link	Max Transfer Rate (MByte/s)	No. of Links	Programmable I/O	Data-way Display	I/O Connectors	p.
V1718	VME	USB 2.0 -> VME	30	1	5 out + 2 in TTL/NIM	Yes	LEMO	139
V2718	VME	Optical Link -> VME	80	1	5 out + 2 in TTL/NIM	Yes	LEMO	140
VX1718	VME64X	USB 2.0 -> VME	30	1	5 out + 2 in TTL/NIM	Yes	LEMO	139
VX2718	VME64X	Optical Link -> VME	80	1	5 out + 2 in TTL/NIM	Yes	LEMO	140
A2818	PCI	PCI -> Optical link	80	1	n / a	n / a	n / a	208
A3818	PCIe	PCIe -> Optical link	80	1 / 2 / 4	n / a	n / a	n / a	208

Discriminators

T20

Model	Package	No. of Channels	Function	Updating	Min Input (mV)	Output Width (ns)	I/O Delay (ns)	Outputs	Input Bandwidth (MHz)	In Conn.	Out Conn.	p.
N605	NIM	4	Const. Fraction	Selectable	- 20	2 ÷ 500	n/a ⁽¹⁾	3 NIM	250	LEMO	LEMO	128
N840	NIM	8	Leading Edge	Selectable	- 5	5 ÷ 40	10	2 + /1 NIM	140	LEMO	LEMO	129
N841	NIM	16	Leading Edge	Selectable	- 5	5 ÷ 40	10	2 + /1 NIM	140	LEMO	LEMO	129
N842	NIM	8	Const. Fraction	No	- 5	16.5 ÷ 273	n/a ⁽¹⁾	2 + /1 NIM	n/a	LEMO	LEMO	129
N843	NIM	16	Const. Fraction	No	- 5	16.5 ÷ 273	n/a ⁽¹⁾	2 + /1 NIM	n/a	LEMO	LEMO	129
N844 ⁽²⁾	NIM	8	Low Threshold	No	- 3	5 ÷ 90	10	2 + /1 NIM	60	LEMO	LEMO	129
N845	NIM	16	Low Threshold	No	- 3	5 ÷ 90	10	2 + /1 NIM	60	LEMO	LEMO	129
V812	VME	16	Const. Fraction	No	- 5	15 ÷ 250	n/a ⁽¹⁾	2 ECL	n/a	LEMO	Std. Flat	141
V814 ⁽²⁾	VME	16	Low Threshold	No	- 1	6 ÷ 95	10	2 ECL	60	LEMO	Std. Flat	141
V895	VME	16	Leading Edge	Selectable	- 5	5 ÷ 40	10	2 ECL	140	LEMO	Std. Flat	142

(1) For constant fraction discriminators, the I/O delay depends on delay set value.

(2) Also available with positive inputs.

Fan In-Fan Out Units⁽¹⁾

T21

Model	Package	No. of Sections	Type	Inputs per Section	Outputs per Section	I/O Delay (ns)	Input Bandwidth (MHz)	Connectors	p.
N454	NIM	4	Logic	4 NIM	4+2 NIM	< 8	100	LEMO	130
N625	NIM	4	Linear	4 Bipolar	4 Bipolar	< 4	100	LEMO	130
V2495	VME	1	Logic User-customizable FPGA: Cyclone V 5CGXC4 (50 K LEs)	64 ECL/PECL/LVDS +2 bidirectional NIM/TTL (expandable up to 162)	32 LVDS +2 bidirectional NIM/TTL (expandable up to 130)	tbd	tbd	Robinson Nugent Flat/LEMO	136
V925	VME	4	Linear	3x4+1x3 Bipolar	3x4+1x3 Bipolar	< 4	120	LEMO	142
V976	VME	4	Logic	4 NIM/TTL	4 NIM/TTL	< 9	150	LEMO	138

(1) All modules are DC coupled.

I/O Registers

T22

Model	Package	No. of Sections	Function	Inputs per Section	Outputs per Section	In Connectors	Out Connectors	p.
V2495	VME	1	Programmable I/O register FPGA: Cyclone V 5CGXC4 (50 K LEs)	64 ECL/PECL/LVDS +2 bidirectional NIM/TTL (expandable up to 162)	32 LVDS +2 bidirectional NIM/TTL (expandable up to 130)	Robinson Nugent Flat/ LEMO	Robinson Nugent Flat/ LEMO	136
V977	VME	1	Pattern Unit, I/O register	16 NIM / TTL	16 NIM / TTL	LEMO	LEMO	143

QDCs

T23

Model	Package	No. of Channels	Resolution (bits)	Conversion Time (μs)	LSB (fC)	Full Scale Range (pC)	Gate Width (μs)	Fast Clear (μs)	Connectors	Features	p.
V792	VME	32	12	5.7	100	400	0.05 ⁽¹⁾	0.6	Std. Flat	-	143
V792N	VME	16	12	2.8	100	400	0.05 ⁽¹⁾	0.6	LEMO	-	143
V862	VME	32	12	5.7	100	400	0.05 ⁽¹⁾	0.6	Robinson Nugent Flat	individual gate	144
V965	VME	16	12 (15 dyn.)	5.7	25 / 200	100 / 900	0.05 ⁽¹⁾	0.6	LEMO	dual range	144
V965A	VME	8	12 (15 dyn.)	2.8	25 / 200	100 / 900	0.05 ⁽¹⁾	0.6	LEMO	dual range	144

(1) Minimum Gate Width.

Scalers

T24

Model	Package	No. of Channels	Input Type	Count Rate (MHz)	Channel Depth	Connectors	p.
N1145	NIM 2U	4+1 downcounter	NIM / TTL	4x250 + 1x80	4x8 + 1x7 digit	LEMO	130
V830	VME	32	ECL / LVDS	250	32 bit	Std. Flat	145
FW1495SC ⁽¹⁾	VME	64 (expandable up to 128)	ECL / LVDS / PECL NIM / TTL ⁽²⁾	270	32 bit	Robinson Nugent Flat / LEMO	138
FW2495SC ⁽³⁾	VME	64 (expandable up to 128)	ECL / LVDS / PECL NIM / TTL ⁽²⁾	tbd	32 bit	Robinson Nugent Flat / LEMO	138

(1) Firmware for Mod. V1495.

(2) For NIM / TTL max 16 channels.

(3) Firmware for Mod. V2495.

TDCs

T25

Model	Package	No. of Channels	Resolution (bit)	Type	Conversion Time (μs)	LSB (ps)	Full Scale Range (μs)	Input Type	Connectors	p.
V1190A-2eSST	VME	128	19 / 17 ⁽¹⁾	Multihit Digital TDC ⁽²⁾	-	100 / 200 / 800	52 / 104	ECL / LVDS	Robinson Nugent Flat	145
V1190B-2eSST	VME	64	19 / 17 ⁽¹⁾	Multihit Digital TDC ⁽²⁾	-	100 / 200 / 800	52 / 104	ECL / LVDS	Robinson Nugent Flat	145
V1290A-2eSST	VME	32	21	Multihit Digital TDC ⁽²⁾	-	25	52	ECL / LVDS	Std. Flat	146
V1290N-2eSST	VME	16	21	Multihit Digital TDC ⁽²⁾	-	25	52	NIM	LEMO	146
V775	VME	32	12	Analog TDC	5.7	35 / 300	0.14 / 1.2	ECL	Std. Flat	147
V775N	VME	16	12	Analog TDC	2.8	35 / 300	0.14 / 1.2	NIM	LEMO	147
VX1190A-2eSST	VME64X	128	19 / 17 ⁽¹⁾	Multihit Digital TDC ⁽²⁾	-	100 / 200 / 800	52 / 104	ECL / LVDS	Robinson Nugent Flat	145
VX1190B-2eSST	VME64X	64	19 / 17 ⁽¹⁾	Multihit Digital TDC ⁽²⁾	-	100 / 200 / 800	52 / 104	ECL / LVDS	Robinson Nugent Flat	145
VX1290A-2eSST	VME64X	32	21	Multihit Digital TDC ⁽²⁾	-	25	52	ECL / LVDS	Std. Flat	146
VX1290N-2eSST	VME64X	16	21	Multihit Digital TDC ⁽²⁾	-	25	52	NIM	LEMO	146

(1) Depending on the selected range.

(2) Based on HPTDC (High Performance Time to Digital Converter) chip developed by CERN/ECP-MIC Division.

Timing Units

T26

Model	Package	No. of Sections	Function	Inputs per Section	Outputs per Section	Output Width/Delay	In Conn.	Out Conn.	p.
N108A	NIM	2	Delay	1 Analog	1 Analog	1.6 ÷ 65.1 ns	LEMO	LEMO	131
N93B	NIM	2	Timer	1 NIM + 1 ECL	2+1 NIM+ 1 ECL	50 ns ÷ 10 s	LEMO / Pin couple	LEMO / Pin couple	131
V972	VME	1	Delay	1 Analog	1 Analog	2.6 ÷ 34.1 ns	LEMO	LEMO	147
V993C	VME 2U	2	Timer	1 NIM/TTL + 1 ECL	2+1 NIM/TTL+ 1 ECL	50 ns ÷ 10 s	LEMO / Pin couple	LEMO / Pin couple	148

Translators

T27

Model	Package	No. Of Sections	Function	Inputs per Section	Outputs per Section	I/O delay (ns)	Input Bandwidth (MHz)	In Conn.	Out Conn.	p.
N638	NIM	2	NIM to ECL/NIM; ECL to NIM/ECL	8 NIM / 8 ECL	2x8 NIM / 8 ECL	< 3.5	300	LEMO / Std. Flat	LEMO / Std. Flat	132
N89	NIM	2	NIM to TTL; TTL to NIM	4 + 4	4 + 4	< 10	60 / 40	LEMO	LEMO	131
V2495	VME	1	Depending on board configuration	64 ECL/PECL/LVDS +2 bidirectional NIM/TTL (expandable up to 162)	32 LVDS+2 bidirectional NIM/TTL (expandable up to 130)	tdb	tdb	Robinson Nugent Flat/ LEMO	Robinson Nugent Flat/ LEMO	136
V538A	VME	1	NIM to ECL/NIM; ECL to NIM/ECL	8 NIM / 8 ECL	2x8 NIM / 2x8 ECL	< 3	300	LEMO / Std. Flat	LEMO / Std. Flat	148
V976	VME	4	NIM to TTL; TTL to NIM	4	4	< 11.5	150	LEMO	LEMO	138

Desktop/Portable Digital MCAs

T28

Model	Inputs	Coupling	Channels	No. of LV Preamp. Outputs	No. of HV Outputs	HV Power Output	Acquisition Modes	Best Suited Detectors	Ports	p.
DT5770	1	DC/AC	16 K	1	0	n/a	Signal Inspector, PHA	HPGe, NaI, LaBr ₃	USB 2.0, Ethernet	182
DT5780M	2	DC	16 K	2	2	+5 kV/300 µA -5 kV/300 µA	Signal Inspector, List Mode	HPGe ⁽³⁾	USB 2.0, Optical Link	179
DT5780N	2	DC	16 K	2	2	-5 kV/300 µA (2 output)	Signal Inspector, List Mode	HPGe ⁽³⁾	USB 2.0, Optical Link	179
DT5780P	2	DC	16 K	2	2	+5 kV/300 µA (2 output)	Signal Inspector, List Mode	HPGe ⁽³⁾	USB 2.0, Optical Link	179
DT5780SCM	2	DC	16 K	2	2	+4 kV/3 mA (4 W max) -4 kV/3 mA (4 W max)	Signal Inspector, List Mode	HPGe ⁽³⁾ , NaI, LaBr ₃	USB 2.0, Optical Link	179
DT5780SCN	2	DC	16 K	2	2	-4 kV/3 mA (2 output) (4 W max)	Signal Inspector, List Mode	HPGe ⁽³⁾ , NaI, LaBr ₃	USB 2.0, Optical Link	179
DT5780SCP	2	DC	16 K	2	2	+4 kV/3 mA (2 output) (4 W max)	Signal Inspector, List Mode	HPGe ⁽³⁾ , NaI, LaBr ₃	USB 2.0, Optical Link	179
DT5780SDM	2	DC	16 K	2	2	+500 V/3 mA -500 V/3 mA	Signal Inspector, List Mode	Si, Diamond	USB 2.0, Optical Link	179
DT5780SDN	2	DC	16 K	2	2	-500 V/3 mA (2 output)	Signal Inspector, List Mode	Si, Diamond	USB 2.0, Optical Link	179
DT5780SDP	2	DC	16 K	2	2	+500 V/3 mA (2 output)	Signal Inspector, List Mode	Si, Diamond	USB 2.0, Optical Link	179
DT5781	4	DC	16 K	0	0	n/a	Signal Inspector, List Mode	HPGe ⁽³⁾ , NaI, LaBr ₃	USB 2.0, Optical Link	181
DT5781A	2	DC	16 K	0	0	n/a	Signal Inspector, List Mode	HPGe ⁽³⁾ , NaI, LaBr ₃	USB 2.0, Optical Link	181
S2580 ⁽¹⁾	1	AC	2 K	n/a	1	+1500 V/500 µA	Signal Inspector, List Mode, PHA, MCS ⁽²⁾ , SCA ⁽²⁾	NaI (14 pin socket)	USB 2.0, Ethernet	184
S2580LB ⁽¹⁾	1	AC	2 K	n/a	1	+1500 V/500 µA	Signal Inspector, List Mode, PHA, MCS ⁽²⁾ , SCA ⁽²⁾	LaBr ₃ (14 pin socket)	USB 2.0, Ethernet	184
S2580G ⁽¹⁾	1	AC	2 K	n/a	1	+1500 V/500 µA	Signal Inspector, List Mode, PHA, MCS ⁽²⁾ , SCA ⁽²⁾	NaI (14 pin socket)	USB 2.0, Ethernet	184
S2580LBG ⁽¹⁾	1	AC	2 K	n/a	1	+1500 V/500 µA	Signal Inspector, List Mode, PHA, MCS ⁽²⁾ , SCA ⁽²⁾	LaBr ₃ (14 pin socket)	USB 2.0, Ethernet	184

(1) Version of Gamma stream.

(2) Coming soon.

(3) Not compliant with transistor reset preamplifier.

NIM Digital MCAs

Model	Inputs	Coupling	Channels	No. of LV Preamp. Outputs	No. of HV Outputs	HV Power Output	Acquisition Modes	Best Suited Detectors	Ports	p.
N6780M	2	DC	16 K	2	2	+5 kV/300 μ A -5 kV/300 μ A	Signal Inspector, List Mode	HPGe ⁽¹⁾	USB 2.0, Optical Link	179
N6780N	2	DC	16 K	2	2	-5 kV/300 μ A (2 output)	Signal Inspector, List Mode	HPGe ⁽¹⁾	USB 2.0, Optical Link	179
N6780P	2	DC	16 K	2	2	+5 kV/300 μ A (2 output)	Signal Inspector, List Mode	HPGe ⁽¹⁾	USB 2.0, Optical Link	179
N6781	4	DC	16 K	0	0	n/a	Signal Inspector, List Mode	HPGe ⁽¹⁾ , NaI, LaBr ₃	USB 2.0, Optical Link	181
N6781A	2	DC	16 K	0	0	n/a	Signal Inspector, List Mode	HPGe ⁽¹⁾ , NaI, LaBr ₃	USB 2.0, Optical Link	181

(1) Not compliant with transistor reset preamplifier.

1) General Information: the following general precautions for handling must be observed during all phases of operation and service of CAEN equipments. Failure to comply with these precautions or with specific warnings elsewhere in the product manual could result in personal injury or damage to the equipment. The precautions listed below represent warnings of certain dangers of which CAEN is aware. You, as the user of the product, should follow these warnings and all other safety precautions necessary for the safe operation of the equipment in your operating environment.

CAEN shall not be liable for user's failure to comply with these requirements







2) Conventions Used in This Document:

CAUTION indicates a hazard that could damage the equipments. Such damage may invalidate the warranty.

3) Safety Terms and Symbols on the Product: these terms may appear on the product:

- **DANGER:** indicates an injury hazard immediately accessible as you read the marking.
- **WARNING:** indicates an injury hazard not immediately accessible as you read the marking.
- **CAUTION:** indicates a hazard that could damage the product.

The following symbols may appear on the product:

 Caution, risk of danger ¹	 Caution, risk of electric shock	 Productive Conductor Terminal
 Earth (Ground) Terminal	 Alternating Current	 Three-Phase Alternating Current

¹ Refer to product manual.

4) Unpacking and Inspection:

CAUTION: observe precautions for handling electrostatic devices.

- Inspect containers for damage during shipment. Report any damage to the freight carrier for possible insurance claims.
- Check that all the components received match those listed on the enclosed packing list. (CAEN cannot accept responsibility for missing items unless we are notified promptly of any discrepancies.)
- Open shipping containers; be careful not to damage contents.
- Inspect contents and report any damage. The inspection should confirm that there is no exterior damage to the unit such as broken knobs or connectors and that the front panel and display face are not scratched or cracked. Keep all packing material until the inspection has been completed.
- If damage is detected, file a claim with carrier immediately and notify CAEN service.
- If equipment must be returned for any reason, carefully repack equipment in the original shipping container with original packing materials if possible. Please contact CAEN service.
- If equipment is to be installed later, replace equipment in original shipping container and store in a safe place until ready to install

5) ESD precautions: CAEN equipments may be classified as ESD sensitive item².

CAUTION: During long term or temporary storage the items shall be covered by ESD protective bags. Handling of the items without ESD protective covering shall be performed only into approved ESD Protected Area (EPAs); any operator shall be properly grounded (e.g. by wrist-straps) before handling the item. Avoid handling operations if the relative humidity is below 30% or take extra ESD safety precautions (such as redundant ground clips) if such handling is unavoidable.

² Excluded all the devices provided with independent case or chassis. Devices that consist of a circuit board with no case or chassis (e.g. VME, CAMAC, NIM modules or HV/LV Power supply boards) comply with the EMC directive if installed in a CE marked system.

6) Storage: CAEN equipments shall be handled and stored in a clean, dust free environment under the following conditions:

	Minimum	Maximum
Temperature	- 30° C	+ 80° C
RH (non-condensing)	5 %	90 %

7) Handling: CAEN equipments shall be handled only with lint-free gloves (e.g. nitrile); never touch the item with bare, ungloved hands.

CAUTION: do not subject the item to undue shock of vibrations; do not bump, drop or slide shipping containers. Do not leave items or shipping containers unsupervised in areas where untrained personnel may mishandle the items.

8) Cleaning: If required the equipments may be cleaned with isopropyl alcohol or deionised water and air dried. Clean the exterior of the product only. Do not apply cleaner directly to the items or allow liquids to enter or spill on the product.

9) Transport:

CAUTION: CAEN equipments can be safely transported in their original shipping packages.

10) Safety Precautions: exercise extreme caution when a shock hazard is present. Lethal voltage may be present on cable connector jacks or test fixtures. **A good safety practice is to expect that hazardous voltage is present in any unknown circuit before operating.** Warning label indicates HV sources which are hazardous to personnel; during test or integration all exposed HV connections shall be insulated or protected.

Before operating an instrument, make sure the line cord is connected to a properly grounded power receptacle. Inspect the connecting cables, test leads, and jumpers for possible wear, cracks, or breaks before each use.

When installing equipment where access to the main power cord is restricted, such as rack mounting, a separate main input power disconnect device must be provided, in close proximity to the equipment and within easy reach of the operator. For maximum safety, do not touch the product, test cables, or any other instruments while power is applied to the circuit under test. ALWAYS disconnect power supply from the entire test system and discharge any capacitors before: connecting or disconnecting cables or jumpers, installing or removing switching cards, or making internal changes, such as installing or removing jumpers.

CAUTION: The instrument and accessories must be used in accordance with its specifications and operating instructions or the safety of the equipment may be impaired.

CAUTION: Do not exceed the maximum signal levels of the instruments and accessories, as defined in the specifications and operating information.

CAUTION: When fuses are used in a product, replace with same type and rating for continued protection against fire hazard.

11) Ventilation Requirements:

CAUTION: All power supplied CAEN NIM, VME and CAMAC modules must be used only with crates with forced cooling air flow.

CAEN modules without power supply, such as Attenuators and Delay units, do not require crates with forced cooling air flow.

CAUTION: Rack bound CAEN HV Power Supply Systems must be installed with a minimum 10cm space both above and below the system.

12) Medical Use: CAEN equipments are not designed with components and testing procedures that would ensure a level of reliability suitable for use in treatment and diagnosis of humans. These items are not intended to be a substitute for any form of established process or equipment used to monitor or safeguard human health and safety in medical treatment.

13) Installation & Operation: only qualified personnel should carry out installation, operation and maintenance procedures.

14) Operating Environmental Requirements:

	Minimum	Maximum
Temperature	0° C	+ 40° C
RH (non-condensing)	10 %	90 %

15) Installing devices with no case or chassis (e.g. VME, CAMAC, NIM modules or HV/LV Power supply boards):

CAUTION: CAEN strongly recommends that you use an antistatic wrist strap and a conductive foam pad when installing these items. After removing the devices from the system or its protective antistatic wrapper, place the component flat on a grounded, static-free surface (and in the case of a board, component side up). Do not slide the component over any surface. Do not stack units on top of each other.

CAUTION: these items should be inserted in the crate only after turning off the power to the crate³. Otherwise, damage to the module is possible due to momentary misalignment of pins on the card edge connector.

³ Excluded modules supporting live insertion/extraction into/from the crate.

CAUTION: To insert a module in the relative crate follow these steps:

- Choose a convenient I/O station.
- Hold the board firmly with both hands (if HV/LV Power supply boards).
- Align the PCB back side with one crate free slot rails.
- Start sliding gently the board along the rails.
- Pay attention to closer boards: insert the module carefully to avoid contacting boards to the right or left.
- Ensure that correct alignment is kept.
- Continue sliding the board holding it firmly.
- Ensure that sliding is smooth.
- Plug the board into Crate backplane connectors with gentle finger pressure.
- Ensure the correct backplane connectors mating.
- Complete installation by screw-locking the board front panel on the crate.

16) Repairs: may be executed by CAEN service only.

Product Index

Model	Description	Family	pp.	CRT	Status
A1015	16 Floating Channel Multipin Radial to SHV connector Adapter for A1515 board (Max: 5 kV - Desktop)	Accessories / Adapters	46		
A1015G	14/16 Stacked Channel Multipin Radial to SHV connector Adapter for A1515TG/A1515QG board (Max: 5 kV - Desktop)	Accessories / Adapters	46		
A1015VM	Analog Voltage Monitor for A1515/A1515TG/A1515QG board	Accessories / Voltage Monitor	46		
A1422	Low Noise Fast Rise Time Charge Sensitive Preamplifiers	Modular Pulse Processing Electronics / Preamplifiers	151	T15/p.224	
A1422H	Low Noise Fast Rise Time Charge Sensitive Preamplifiers (Hybrid)	Modular Pulse Processing Electronics / Preamplifiers	150	T15/p.224	
A1423B	Wideband Amplifier	Modular Pulse Processing Electronics / Preamplifiers	153		
A1424	Scintillation Preamplifier	Modular Pulse Processing Electronics / Preamplifiers	152	T16/p.224	
A1425	Fast Charge Preamplifier	Modular Pulse Processing Electronics / Preamplifiers	152	T17/p.224	NEW
A1426 CARDARELLI	Matched Preamplifier	Modular Pulse Processing Electronics / Preamplifiers	153	T17/p.224	COMING SOON
A1481	Kill Signal Adapter for N14xx Series	Accessories / Adapters	208		
A1510	12 Channel 100 V, 1/10 mA Individual Floating Channel Dual Range Board	Power Supplies / Universal Multichannel Systems / Multichannel Boards	32	T2/p.218	
A1511B	12 Channel 500 V, 1/10 mA Individual Floating Channel Dual Range Board	Power Supplies / Universal Multichannel Systems / Multichannel Boards	32	T2/p.218	
A1512	12 Channel 500 V, 1 mA/100 μ A Individual Floating Channel Dual Range Board	Power Supplies / Universal Multichannel Systems / Multichannel Boards	32	T2/p.218	
A1513B	6 Channel 10 V/2.7 A Individual Floating Channel Board	Power Supplies / Universal Multichannel Systems / Multichannel Boards	27	T2/p.218	
A1515	16 Channel Floating 1kV, 1/0.1 mA Board	Power Supplies / Universal Multichannel Systems / Multichannel Boards	37	T2/p.218	NEW
A1515QG	16 Channel Floating 1kV, 1/0.1 mA Board for Quadruple GEM detectors	Power Supplies / Universal Multichannel Systems / Multichannel Boards	37	T2/p.218	NEW
A1515TG	14 Channel Floating 1kV, 1/0.1 mA Board for Triple GEM detectors	Power Supplies / Universal Multichannel Systems / Multichannel Boards	37	T2/p.218	NEW
A1516B	6 Channel 15 V/1.5 A Individual Floating Channel Board	Power Supplies / Universal Multichannel Systems / Multichannel Boards	27	T2/p.218	
A1517B	6 Channel 7 V/4 A Individual Floating Channel Board	Power Supplies / Universal Multichannel Systems / Multichannel Boards	27	T2/p.218	
A1518B	6 Channel 4.5 V/6 A Individual Floating Channel Board	Power Supplies / Universal Multichannel Systems / Multichannel Boards	27	T2/p.218	
A1519B	12 Channel 250 V, 0.1/1 mA Individual Floating Channel Dual Range Board	Power Supplies / Universal Multichannel Systems / Multichannel Boards	32	T2/p.218	
A1520P	12 Channel 500 V/15 mA Individual Floating Channel Board	Power Supplies / Universal Multichannel Systems / Multichannel Boards	32	T2/p.218	
A1523	6 Channel 12 kV/1 mA Common Floating Return Board	Power Supplies / Universal Multichannel Systems / Multichannel Boards	42	T4/p.219	
A1524	6 Channel 12 kV/100 μ A Common Floating Return Board	Power Supplies / Universal Multichannel Systems / Multichannel Boards	42	T4/p.219	
A1526	6 Channel 15 kV, 1/0.1 mA Common Floating Return Board	Power Supplies / Universal Multichannel Systems / Multichannel Boards	44	T4/p.219	
A1534	12 Channel 8 kV/200 μ A Individual Floating Channel Board	Power Supplies / Universal Multichannel Systems / Multichannel Boards	39	T2/p.218	
A1535	12/24 Channel 3.5 kV/3 mA (9 W) Common Floating Return Boards	Power Supplies / Universal Multichannel Systems / Multichannel Boards	33	T4/p.219	
A1536	12/24/32 Channel 3 kV/1 mA Common Floating Return Boards	Power Supplies / Universal Multichannel Systems / Multichannel Boards	33	T4/p.219	
A1538D	12 Channel 1.5 kV/10 mA (12W) Common Floating Return Board	Power Supplies / Universal Multichannel Systems / Multichannel Boards	33	T4/p.219	
A1539	12/24/32 Channel 100 V/15 mA Common Floating Return Boards	Power Supplies / Universal Multichannel Systems / Multichannel Boards	28	T4/p.219	NEW
A1540	12/24/32 Channel 100 V/1 mA Common Floating Return Boards	Power Supplies / Universal Multichannel Systems / Multichannel Boards	28	T4/p.219	NEW
A1540H	12/24/32 Channel 100 V, 15 mA/20 μ A Common Floating Return Dual Range Boards	Power Supplies / Universal Multichannel Systems / Multichannel Boards	28	T4/p.219	NEW
A1541	12/24/32 Channel 500 V/10 mA Common Floating Return Boards	Power Supplies / Universal Multichannel Systems / Multichannel Boards	28	T4/p.219	NEW
A1542	12/24/32 Channel 500 V/1 mA Common Floating Return Boards	Power Supplies / Universal Multichannel Systems / Multichannel Boards	28	T4/p.219	NEW
A1542H	12/24/32 Channel 500 V, 10 mA/20 μ A Common Floating Return Dual Range Boards	Power Supplies / Universal Multichannel Systems / Multichannel Boards	28	T4/p.219	NEW
A1550	12/24/32 5 kV/1 mA Common Floating Return Boards	Power Supplies / Universal Multichannel Systems / Multichannel Boards	39	T4/p.219	
A1560H	8/16 Channel 6 kV/20 μ A Common Floating Return Boards	Power Supplies / Universal Multichannel Systems / Multichannel Boards	41	T4/p.219	NEW

Product Index (continued)

Model	Description	Family	pp.	CRT	Status
A1561H	12 Channel 6 kV/20 μ A Common Floating Return Board	Power Supplies / Universal Multichannel Systems / Multichannel Boards	39	T4/p.219	
A1580H	8/16 Channel 8 kV/20 μ A Common Floating Return Boards	Power Supplies / Universal Multichannel Systems / Multichannel Boards	41	T4/p.219	NEW
A1588	8 Channel \pm 2 kV/500 μ A 4 Quadrant Bipolar Board	Power Supplies / Universal Multichannel Systems / Multichannel Boards	45		
A1590	16 Channel 9 kV/100 μ A Common Floating Return Board	Power Supplies / Universal Multichannel Systems / Multichannel Boards	42	T4/p.219	NEW
A1676A	EASY Branch Controller	Power Supplies / EASY	66		
A1702	32 Channel Silicon Photomultipliers Readout Front-End Board	Readout Systems	197		NEW
A1821	12 Channel 3 kV, 200/20 μ A Common Ground Dual Range Board	Power Supplies / Universal Multichannel Systems / Multichannel Boards	33	T3/p.219	
A1821H	12 Channel 3 kV, 200/10 μ A Common Ground Dual Range Board	Power Supplies / Universal Multichannel Systems / Multichannel Boards	33	T3/p.219	
A1833	12 Channel 3 kV/3mA, 4 kV/2 mA, 4 kV/0.2 mA Common Ground Dual Range Board	Power Supplies / Universal Multichannel Systems / Multichannel Boards	33	T3/p.219	
A2517	8 Channel 5 V/15 A (50 W) Individual Floating Channel Board	Power Supplies / Universal Multichannel Systems / Multichannel Boards	27	T2/p.218	
A2518	8 Channel 8 V/10 A (50 W) Individual Floating Channel Boards	Power Supplies / Universal Multichannel Systems / Multichannel Boards	27	T2/p.218	
A2519	8 Channel 15V/5 A (50 W) Individual Floating Channel Boards	Power Supplies / Universal Multichannel Systems / Multichannel Boards	27	T2/p.218	
A2795	Liquid Argon TPC Readout Board	Readout Systems	194		NEW
A2818	PCI CONET Controller	Accessories / Optical Controllers	208	T19/p.225	
A3000Fx	EASY Fan Units	Power Supplies / EASY	66		
A309 - A310 - A311 A312 - A313	Single Channel Fixed Attenuators	Accessories / Fixed Attenuators	210		
A30xx	EASY Power Supplies	Power Supplies / EASY	66		
A3100x	EASY Power Supplies	Power Supplies / EASY	66		
A315	Splitter	Accessories / Splitter	211		
A317	Clock Distribution Cable	Accessories / Cables	211		
A318	Single-Ended to Differential Cable Adapter	Accessories / Adapters	211		
A348x	EASY Bulk Power Supplies	Power Supplies / EASY	66		
A3602 - A35xx	EASY Power Supplies	Power Supplies / EASY	66		
A380x	EASY Front-End Boards	Power Supplies / EASY	66		
A3818	PCI Express CONET2 Controller	Accessories / Optical Controllers	208	T19/p.225	
A385 - A392	16 Channel LEMO Adapters	Accessories / Adapters	208		
A395A	32 LVDS/ECL/PECL input channels (Piggyback board)	Modular Pulse Processing Electronics / VME	137		
A395B	32 LVDS output channels (Piggyback board)	Modular Pulse Processing Electronics / VME	137		
A395C	32 ECL output channels (Piggyback board)	Modular Pulse Processing Electronics / VME	137		
A395D	8 NIM/TTL input/output channels (Piggyback board)	Modular Pulse Processing Electronics / VME	137		
A395E	8 Analog output 16-bit channels (Piggyback board)	Modular Pulse Processing Electronics / VME	137		
A422A	Charge Sensitive Preamplifier with Timing	Modular Pulse Processing Electronics / Preamplifiers	150	T15/p.224	
A4528x	SY4527/SY5527 CPU Modules	Power Supplies / Universal Multichannel Systems / Mainframes	21		
A4531	SY4527/SY5527 Primary Power Supply 600 W	Power Supplies / Universal Multichannel Systems / Mainframes	21		
A4532	SY4527/SY5527 Optional Single Power Supply Unit 600 W	Power Supplies / Universal Multichannel Systems / Mainframes	21		
A4533	SY4527/SY5527 Optional Single Power Supply Unit 1200 W	Power Supplies / Universal Multichannel Systems / Mainframes	21		
A483	HV Bidirectional Passive HV Filter	Accessories / HV Filter	210		

Product Index (continued)

Model	Description	Family	pp.	CRT	Status
A646	12 Channel DB37 to SHV connector Adapter (Max: 500V - Desktop)	Accessories / Adapters	46		
A647	24 Channel Multipin Radial to SHV connector Adapter (Max: 8kV - Desktop)	Accessories / Adapters	46		
A648	48 Channel Multipin Radial to SHV connector Adapter (Max: 3kV - Desktop)	Accessories / Adapters	46		
A649	32 Channel Multipin Radial to SHV connector Adapter (Max: 3kV - Desktop)	Accessories / Adapters	46		
A649B	32 Channel Multipin to SHV connector Adapter (Max: 8 kV - Desktop)	Accessories / Adapters	46		
A654	MCX to LEMO Cable Adapters	Accessories / Adapters	208		
A659	MCX to BNC Cable Adapters	Accessories / Adapters	208		
A7030	12/24/36/48 Channel 3 kV/1 mA (1.5W) Common Floating Return Boards	Power Supplies / Universal Multichannel Systems / Multichannel Boards	36	T4/p.219	NEW
A7040	12/24/36/48 Channel 100 V/500 μ A Common Floating Return Boards	Power Supplies / Universal Multichannel Systems / Multichannel Boards	31	T4/p.219	COMING SOON
A7042	12/24/36/48 Channel 500 V/500 μ A Common Floating Return Boards	Power Supplies / Universal Multichannel Systems / Multichannel Boards	31	T4/p.219	NEW
A7236	32 Channel 3.5 kV/1.5 mA (4W) Common Floating Return Board	Power Supplies / Universal Multichannel Systems / Multichannel Boards	38	T4/p.219	NEW
A7435	24 Channel 3.5 kV/3.5 mA (9W) Common Floating Return Board	Power Supplies / Universal Multichannel Systems / Multichannel Boards	38	T4/p.219	NEW
A746B	64 Channel Adapter for LEMO Connector (VME)	Accessories / Adapters	209		
A746D	32 Channel Adapter for LEMO Connector (NIM)	Accessories / Adapters	209		
A746E	32 Channel Adapter for LEMO Connector (DT)	Accessories / Adapters	209		
A7501	1 Ch 2100 V/100 μ A High Efficiency HV Power Supply Module	Power Supplies / Standalone Power Supplies / PCB High Voltage Power Supplies	62	T8/p.221	NEW
A7501PB	Single Channel High Reliability, High Voltage Power Supply Box	Power Supplies / Standalone Power Supplies / PCB High Voltage Power Supplies	64		NEW
A7504	1 Ch 4000 V/100 μ A High Efficiency HV Power Supply Module	Power Supplies / Standalone Power Supplies / PCB High Voltage Power Supplies	62	T8/p.221	NEW
A7505	1 Ch 1600 V/500 μ A High Efficiency HV Power Supply Module	Power Supplies / Standalone Power Supplies / PCB High Voltage Power Supplies	62	T8/p.221	NEW
A7508	1 Ch 800V/50 μ A High Efficiency HV Power Supply Module	Power Supplies / Standalone Power Supplies / PCB High Voltage Power Supplies	62	T8/p.221	NEW
A7560	2 Ch Bipolar \pm 6kV/10 μ A High Performance HV Power Supply Module	Power Supplies / Standalone Power Supplies / PCB High Voltage Power Supplies	63	T8/p.221	NEW
A83xx	General Purpose 1U Fan Unit	Accessories / Fan Units	211		NEW
		Modular Pulse Processing Electronics / Powered Crates	176		NEW
A954	16 Channel to 2x8 Channel Cable Adapter	Accessories / Adapters	209		
A967	32 Channel Cable Adapter for V767, V862, V1190, VX1190, Vx495, DT5495	Accessories / Adapters	209		
A992	16 Channel Impedance Adapter	Accessories / Adapters	209		
A995	Insertion/Extraction Tool for A996	Accessories / HV Connectors	210		
A996	52 Pin Cable Connector	Accessories / HV Connectors	210		
A997	HV Coaxial Cable Connector for CPE HV	Accessories / HV Connectors	210		
AG523	6 Channel 12 kV/1 mA Common Ground Board	Power Supplies / Universal Multichannel Systems / Multichannel Boards	42	T3/p.219	
AG524	6 Channel 12 kV/100 μ A Common Ground Board	Power Supplies / Universal Multichannel Systems / Multichannel Boards	42	T3/p.219	
AG535	12/24 Channel 3.5 kV/3 mA (6 W) Common Ground Boards	Power Supplies / Universal Multichannel Systems / Multichannel Boards	33	T3/p.219	
AG536	12/24/32 Channel 3 kV/1 mA Common Ground Boards	Power Supplies / Universal Multichannel Systems / Multichannel Boards	33	T3/p.219	
AG538D	12 Channel 1.5 kV/10 mA (12W) Common Ground Board	Power Supplies / Universal Multichannel Systems / Multichannel Boards	33	T3/p.219	
AG539	12/24/32 Channel 100 V/15 mA Common Ground Boards	Power Supplies / Universal Multichannel Systems / Multichannel Boards	28	T3/p.219	NEW
AG540	12/24/32 Channel 100 V/1 mA Common Ground Boards	Power Supplies / Universal Multichannel Systems / Multichannel Boards	28	T3/p.219	NEW
AG541	12/24/32 Channel 500 V/10 mA Common Ground Boards	Power Supplies / Universal Multichannel Systems / Multichannel Boards	28	T3/p.219	NEW

Product Index (continued)

Model	Description	Family	pp.	CRT	Status
AG542	12/24/32 Channel 500 V/1 mA Common Ground Boards	Power Supplies / Universal Multichannel Systems / Multichannel Boards	28	T3/p.219	NEW
AG550	12/24/32 Channel 5 kV/1 mA Common Ground Boards	Power Supplies / Universal Multichannel Systems / Multichannel Boards	39	T3/p.219	
AG590	16 Channel 9 kV/100 μ A Common Ground Board	Power Supplies / Universal Multichannel Systems / Multichannel Boards	42	T3/p.219	NEW
AG7030	12/24/36/48 Channel 3 kV/1 mA (1.5W) Common Ground Boards	Power Supplies / Universal Multichannel Systems / Multichannel Boards	36	T3/p.219	NEW
AG7040	12/24/36/48 Channel 100 V/500 μ A Common Ground Boards	Power Supplies / Universal Multichannel Systems / Multichannel Boards	31	T3/p.219	COMING SOON
AG7042	12/24/36/48 Channel 500 V/500 μ A Common Ground Boards	Power Supplies / Universal Multichannel Systems / Multichannel Boards	31	T3/p.219	NEW
AG7236	32 Channel 3.5 kV/1.5 mA (4W) Common Ground Board	Power Supplies / Universal Multichannel Systems / Multichannel Boards	38	T3/p.219	NEW
AG7435	24 Channel 3.5 kV/3.5 mA (9W) Common Ground Board	Power Supplies / Universal Multichannel Systems / Multichannel Boards	38	T3/p.219	NEW
AI2700	Optical Fiber Series	Accessories / Cables	210		
AP932	1 Channel 3 kV/30mA Individual Floating Board (SHV conn)	Power Supplies / Universal Multichannel Systems / Multichannel Boards	33	T2/p.218	
CAEN HV Wrapper	Library for CAEN Power Supply Control	Power Supplies / Power Supply Control Software	73		
CAEN SyncTest	Demo Software for CAEN Digitizers Synchronization	Modular Pulse Processing Electronics / Waveform Digitizers / Tools / Configuration Tools	120		
CAEN VME Demos	Demo Applications for CAEN Bridges Control	Modular Pulse Processing Electronics / Waveform Digitizers / Tools / Configuration Tools	120		
CAENComm	Interface Library for CAEN Data Acquisition Modules	Modular Pulse Processing Electronics / Waveform Digitizers / Tools / Libraries	119		
CAENDigitizer	Library of Functions for CAEN Digitizers High Level Management	Modular Pulse Processing Electronics / Waveform Digitizers / Tools / Libraries	119		
CAENDPP	High Level Library for CAEN Boards Running DPP Firmware	Modular Pulse Processing Electronics / Waveform Digitizers / Tools / Libraries	119		
CAENScope	CAEN Digitizer Signal Inspection and Waveform Recording Software	Modular Pulse Processing Electronics / Waveform Digitizers / Waveform Recording	109		
CAENUpgrader	Firmware Upgrade Tool for Front-end Boards Bridges & VME Power Supply	Modular Pulse Processing Electronics / Waveform Digitizers / Tools / Configuration Tools	120		
CoMPASS	Multiparametric DAQ Software for Physics Applications	Modular Pulse Processing Electronics / Waveform Digitizers / Digital Pulse Processing	112		NEW
DPP-CRAMS	Digital Pulse Processing for CAEN Readout of Analog Multiplexed Signals (x724)	Readout Systems	195		
DPP-DAW	Channel Independent Zero Suppression with Dynamic Acquisition Window	Modular Pulse Processing Electronics / Waveform Digitizers / Digital Pulse Processing	117		NEW
DPP-DAW Demo Software	Software interface for DPP-DAW management	Modular Pulse Processing Electronics / Waveform Digitizers / Digital Pulse Processing	117		NEW
DPP-PHA	Digital Pulse Processing for Pulse Height Analysis	Modular Pulse Processing Electronics / Waveform Digitizers / Digital Pulse Processing	113		
DPP-PSD	Digital Charge Integration and Pulse Shape Analysis	Modular Pulse Processing Electronics / Waveform Digitizers / Digital Pulse Processing	114		
DPP-PSD Control Software	Graphical Interface for DPP-PSD Management	Digital Spectroscopy / Software	185		
		Modular Pulse Processing Electronics / Waveform Digitizers / Digital Pulse Processing	114		
DPP-QDC	Digital Charge to Digital Converter for 740 Digitizer	Modular Pulse Processing Electronics / Waveform Digitizers / Digital Pulse Processing	115		NEW
DPP-QDC Demo Software	Software interface for DPP-QDC management	Modular Pulse Processing Electronics / Waveform Digitizers / Digital Pulse Processing	115		NEW
DPP-ZLEplus	Advanced Zero Length Encoding	Modular Pulse Processing Electronics / Waveform Digitizers / Digital Pulse Processing	116		
DPP-ZLEplus Demo Software	Software interface for DPP-ZLEplus management	Modular Pulse Processing Electronics / Waveform Digitizers / Digital Pulse Processing	116		
DT1419ET	4 Ch Reversible 500 V/200 μ A Desktop HV Power Supply Module (USB/Ethernet/T.screen)	Power Supplies / Standalone Power Supplies / Desktop High Voltage Power Supplies	58	T7/p.221	NEW
DT1470ET	4 Ch Reversible 8 kV/3 mA (8 W) Desktop HV Power Supply Module (USB/Ethernet/T.screen)	Power Supplies / Standalone Power Supplies / Desktop High Voltage Power Supplies	58	T7/p.221	NEW
DT1471ET	4 Ch Reversible 5.5 kV/300 μ A Desktop HV Power Supply Module (USB/Ethernet/T.screen)	Power Supplies / Standalone Power Supplies / Desktop High Voltage Power Supplies	58	T7/p.221	NEW
DT1471HET	4 Ch Reversible 5.5 kV/20 μ A Desktop HV Power Supply High Accuracy Module (USB/Ethernet/T.screen)	Power Supplies / Standalone Power Supplies / Desktop High Voltage Power Supplies	58	T7/p.221	NEW
DT4800	Micro Digital Detector Emulator	Digital Detector Emulators / Desktop	204		NEW
DT5423	Quad Desktop Power distributor	Modular Pulse Processing Electronics / Preamplifiers	154		

Product Index (continued)

Model	Description	Family	pp.	CRT	Status
		<i>Power Supplies / Standalone Power Supplies / Desktop Low Voltage Power Supplies</i>	60		
DT5470	1 Ch 5 kV/200 μ A USB-Powered Desktop HV Power Supply	<i>Power Supplies / Standalone Power Supplies / Desktop High Voltage Power Supplies</i>	59	T7/p.221	NEW
DT5471	1 Ch 3 kV/500 μ A (1 W) USB-Powered Desktop HV Power Supply	<i>Power Supplies / Standalone Power Supplies / Desktop High Voltage Power Supplies</i>	59	T7/p.221	NEW
DT5472	1 Ch 500 V/1 mA USB-Powered Desktop HV Power Supply	<i>Power Supplies / Standalone Power Supplies / Desktop High Voltage Power Supplies</i>	59	T7/p.221	NEW
DT5519E	4 Channel 500 V/3 mA Desktop HV Power Supply Module (USB/Ethernet)	<i>Power Supplies / Standalone Power Supplies / Desktop High Voltage Power Supplies</i>	56	T7/p.221	NEW
DT5521E	4 Channel 6 kV/300 μ A Desktop HV Power Supply Module (USB/Ethernet)	<i>Power Supplies / Standalone Power Supplies / Desktop High Voltage Power Supplies</i>	56	T7/p.221	NEW
DT5521HE	4 Channel 6 kV/20 μ A Desktop HV Power Supply Module (USB/Ethernet)	<i>Power Supplies / Standalone Power Supplies / Desktop High Voltage Power Supplies</i>	56	T7/p.221	NEW
DT5533E	4 Channel 4 kV/3 mA (4 W) Desktop HV Power Supply Module (USB/Ethernet)	<i>Power Supplies / Standalone Power Supplies / Desktop High Voltage Power Supplies</i>	56	T7/p.221	NEW
DT5534E	4 Channel 6 kV/1 mA (4 W) Desktop HV Power Supply Module (USB/Ethernet)	<i>Power Supplies / Standalone Power Supplies / Desktop High Voltage Power Supplies</i>	56	T7/p.221	NEW
DT5550	32 Channel DAQ System with Programmable FPGA and Sequencer	<i>Readout Systems</i>	196		COMING SOON
DT5720	4/2 Channel 12-bit 250 MS/s Digitizer	<i>Modular Pulse Processing Electronics / Waveform Digitizers / 720 Digitizer Family</i>	90	T11/p.223	
DT5724	4/2 Channel 14-bit 100 MS/s Digitizer	<i>Modular Pulse Processing Electronics / Waveform Digitizers / 724 Digitizer Family</i>	92	T11/p.223	
DT5725	8 Channel 14-bit 250 MS/s Digitizer	<i>Modular Pulse Processing Electronics / Waveform Digitizers / 725 Digitizer Family</i>	94	T11/p.223	NEW
DT5730	8 Channel 14-bit 500 MS/s Digitizer	<i>Modular Pulse Processing Electronics / Waveform Digitizers / 730 Digitizer Family</i>	96	T11/p.223	
DT5740	32 Channel 12-bit 62.5MS/s Digitizer	<i>Modular Pulse Processing Electronics / Waveform Digitizers / 740 Digitizer Family</i>	98	T11/p.223	
DT5742	16+1 Channel 12-bit 5 GS/s Switched Capacitor Digitizer	<i>Modular Pulse Processing Electronics / Waveform Digitizers / 742 Digitizer Family</i>	104	T11/p.223	
DT5743	8 Channel 12-bit 3.2 GS/s Switched Capacitor Digitizer	<i>Modular Pulse Processing Electronics / Waveform Digitizers / 743 Digitizer Family</i>	106	T11/p.223	
DT5751	2-4 Channel 10-bit 2/1 GS/s Digitizer	<i>Modular Pulse Processing Electronics / Waveform Digitizers / 751 Digitizer Family</i>	100	T11/p.223	
DT5761	1 Channel 10-bit 4 GS/s Digitizer	<i>Modular Pulse Processing Electronics / Waveform Digitizers / 761 Digitizer Family</i>	102	T11/p.223	
DT5770	Digital Multichannel Analyzer - Desktop	<i>Digital Spectroscopy / Digital Multichannel Analyzers</i>	182	T28/p.227	NEW
DT5780	Dual Digital Multichannel Analyzer (HV & Preamplifier PS) - Desktop	<i>Digital Spectroscopy / Digital Multichannel Analyzers</i>	179	T28/p.227	
DT5781	Dual/Quad Digital Multichannel Analyzer - Desktop	<i>Digital Spectroscopy / Digital Multichannel Analyzers</i>	181	T28/p.227	NEW
DT5790	Dual Digital Pulse Shape Discriminator	<i>Digital Spectroscopy / Digital Pulse Analyzers</i>	183		
DT5800	Desktop Digital Detector Emulator	<i>Digital Detector Emulators / Desktop</i>	205		
DT5810	Desktop Fast Digital Detector Emulator	<i>Digital Detector Emulators / Desktop</i>	203		NEW
EASY3000x	EASY Crates	<i>Power Supplies / EASY</i>	66		
EPICS IOC (PSM)	EPICS IOC for Power Supply Modules	<i>Power Supplies / Power Supply Control Software</i>	78		
EPICS IOC (SY4527 / SY5527)	EPICS IOC for SY4527 and SY5527 Systems	<i>Power Supplies / Power Supply Control Software</i>	78		
FW1495CRAMS	Sequencer firmware for CAEN Readout of Analog Multiplexed Signals (V1495)	<i>Readout Systems</i>	195		
FW495SC	128 Ch Multievent Latching Scaler	<i>Modular Pulse Processing Electronics / VME</i>	138		
Gamma stream	Active, stand-alone, fully featured MCA tube base for scintillation	<i>Digital Spectroscopy / Stand-Alone MCA Tube Base</i>	184	T28/p.227	NEW
GammaTOUCH	Gamma stream Control Software for Android™	<i>Digital Spectroscopy / Software</i>	185		
GECO2020	General Control Software for CAEN HV Power Supplies	<i>Power Supplies / Power Supply Control Software</i>	72		
HEXAGON	Dual Digital Multichannel Analyzer (HV & Preamplifier PS - LCD) - Desktop	<i>Digital Spectroscopy / Digital Multichannel Analyzers</i>	178		COMING SOON
HiVoCS	Web based Control Software for SY4527 and SY5527 Systems	<i>Power Supplies / Power Supply Control Software</i>	74		
LabVIEW Driver	Instrument Driver for Power Supply Modules	<i>Power Supplies / Power Supply Control Software</i>	76		

Product Index (continued)

Model	Description	Family	pp.	CRT	Status
MC²Analyzer	Digital MCA Data Acquisition and Analysis Software	<i>Digital Spectroscopy / Software</i>	185		
	User Friendly Software for Digital Pulse Height Analysis	<i>Modular Pulse Processing Electronics / Waveform Digitizers / Digital Pulse Processing</i>	113		
N1068	16 Ch Programmable Spectroscopy Amplifier with Time Filter, CFD and pile-up rejection	<i>Modular Pulse Processing Electronics / NIM</i>	124	T13/p.224	NEW
N108A	Dual Delay	<i>Modular Pulse Processing Electronics / NIM</i>	131	T26/p.227	
N113	Dual OR 12 In - 2 Out	<i>Modular Pulse Processing Electronics / NIM</i>	127	T18/p.224	
N1145	Quad Scaler and Preset Counter / Timer	<i>Modular Pulse Processing Electronics / NIM</i>	130	T24/p.226	
N1168	16 Ch Fast Scintillator Programmable Signal Processor and 16 ch CFD	<i>Modular Pulse Processing Electronics / NIM</i>	125		COMING SOON
N1419/A/B	4/2/1 Ch Reversible 500 V/200 μ A NIM HV Power Supply Module (USB)	<i>Power Supplies / NIM High Voltage Power Supplies</i>	50	T6/p.220	
N1419ET	4 Ch Reversible 500 V/200 μ A NIM HV Power Supply Module (USB/Ethernet/Tscreen)	<i>Power Supplies / NIM High Voltage Power Supplies</i>	50	T6/p.220	
N1470/A/B	4/2/1 Ch Reversible 8 kV/3 mA (8 W) NIM HV Power Supply Module (USB)	<i>Power Supplies / NIM High Voltage Power Supplies</i>	50	T6/p.220	
N1470AL	2 Ch Reversible 8 kV/3 mA (8 W) NIM HV Power Supply Module Low Cost Locally Programmable	<i>Power Supplies / NIM High Voltage Power Supplies</i>	50	T6/p.220	
N1470AR	2 Ch Reversible 8 kV/3 mA (8 W) NIM HV Power Supply Module (USB) Low Cost Remotely Programmable	<i>Power Supplies / NIM High Voltage Power Supplies</i>	50	T6/p.220	
N1470ET	4 Ch Reversible 8 kV/3 mA (8 W) NIM HV Power Supply Module (USB/Ethernet/T screen)	<i>Power Supplies / NIM High Voltage Power Supplies</i>	50	T6/p.220	
N1471/A/B	4/2/1 Ch Reversible 5.5 kV/300 μ A NIM HV Power Supply Module (USB)	<i>Power Supplies / NIM High Voltage Power Supplies</i>	50	T6/p.220	
N1471ET	4 Ch Reversible 5.5 kV/300 μ A NIM HV Power Supply Module (USB/Ethernet/T screen)	<i>Power Supplies / NIM High Voltage Power Supplies</i>	50	T6/p.220	
N1471H/A/B	4/2/1 Ch Reversible 5.5 kV/20 μ A NIM HV Power Supply High Accuracy Module (USB)	<i>Power Supplies / NIM High Voltage Power Supplies</i>	50	T6/p.220	
N1471HET	4 Ch Reversible 5.5 kV/20 μ A NIM HV Power Supply High Accuracy Module (USB/Ethernet/T.screen)	<i>Power Supplies / NIM High Voltage Power Supplies</i>	50	T6/p.220	
N1568A	16 Ch Programmable Spectroscopy Amplifier & Dual 16 Ch CFD (30%; 80%)	<i>Modular Pulse Processing Electronics / NIM</i>	126	T13/p.224	
N1568ADAT	USB RS485 Adapter Board	<i>Accessories / Adapters</i>	209		
N1570	2 Channel 15 kV/1 mA (10 W) NIM HV Power Supply Module (USB/Ethernet/T.screen)	<i>Power Supplies / NIM High Voltage Power Supplies</i>	53	T6/p.220	NEW
N405	Triple 4-Fold Logic Unit/Majority with VETO	<i>Modular Pulse Processing Electronics / NIM</i>	127	T18/p.224	
N454	4 - 8 Logic Fan In-Fan Out	<i>Modular Pulse Processing Electronics / NIM</i>	130	T21/p.225	
N455	Quad Coincidence Logic Unit	<i>Modular Pulse Processing Electronics / NIM</i>	128	T18/p.224	
N472	4 Channel 6 kV Power Supply	<i>Power Supplies / NIM High Voltage Power Supplies</i>	52	T6/p.220	
		<i>Power Supplies / NIM Low Voltage Power Supplies</i>	54		
N5424	Quad NIM Power distributor	<i>Modular Pulse Processing Electronics / Preamplifiers</i>	154		
		<i>Power Supplies / NIM Low Voltage Power Supplies</i>	54		
N568E	16 Channel Programmable Spectroscopy Amplifier (Low Noise)	<i>Modular Pulse Processing Electronics / NIM</i>	128	T13/p.224	
N568EB	16 Channel Programmable Spectroscopy Amplifier (Low Noise)	<i>Modular Pulse Processing Electronics / NIM</i>	128	T13/p.224	
N568ELC	16 Channel Programmable Spectroscopy Amplifier	<i>Modular Pulse Processing Electronics / NIM</i>	128	T13/p.224	
N605	4 Channel 200 MHz Constant Fraction Discriminator	<i>Modular Pulse Processing Electronics / NIM</i>	128	T20/p.225	NEW
N625	Quad Linear Fan In-Fan Out	<i>Modular Pulse Processing Electronics / NIM</i>	130	T21/p.225	
N638	16 Channel NIM-ECL/ECL-NIM Translator and Fan Out	<i>Modular Pulse Processing Electronics / NIM</i>	132	T27/p.227	
N6720	2/4 Channel 12-bit 250 MS/s Digitizer	<i>Modular Pulse Processing Electronics / Waveform Digitizers / 720 Digitizer Family</i>	90	T11/p.223	
N6724	4/2 Channel 14-bit 100 MS/s Digitizer	<i>Modular Pulse Processing Electronics / Waveform Digitizers / 724 Digitizer Family</i>	92	T11/p.223	
N6725	8 Channel 14-bit 250 MS/s Digitizer	<i>Modular Pulse Processing Electronics / Waveform Digitizers / 725 Digitizer Family</i>	94	T11/p.223	NEW
N6730	8 Channel 14-bit 500 MS/s Digitizer	<i>Modular Pulse Processing Electronics / Waveform Digitizers / 730 Digitizer Family</i>	96	T11/p.223	
N6740	32 Channel 12-bit 62.5 MS/s Digitizer	<i>Modular Pulse Processing Electronics / Waveform Digitizers / 740 Digitizer Family</i>	98	T11/p.223	

Product Index (continued)

Model	Description	Family	pp.	CRT	Status
N6742	16+1 Channel 12-bit 5 GS/s Switched Capacitor Digitizer	<i>Modular Pulse Processing Electronics / Waveform Digitizers / 742 Digitizer Family</i>	104	T11/p.223	
N6743	8 Channel 12-bit 3.2 GS/s Switched Capacitor Digitizer	<i>Modular Pulse Processing Electronics / Waveform Digitizers / 743 Digitizer Family</i>	106	T11/p.223	
N6751	2-4 Channel 10-bit 2/1 GS/s Digitizer	<i>Modular Pulse Processing Electronics / Waveform Digitizers / 751 Digitizer Family</i>	100	T11/p.223	
N6761	1 Channel 10-bit 4 GS/s Digitizer	<i>Modular Pulse Processing Electronics / Waveform Digitizers / 761 Digitizer Family</i>	102	T11/p.223	
N6780	Dual Digital Multichannel Analyzer (HV & Preamplifier PS) - NIM	<i>Digital Spectroscopy / Digital Multichannel Analyzers</i>	179	T29/p.228	
N6781	Dual/Quad Digital Multichannel Analyzer - NIM	<i>Digital Spectroscopy / Digital Multichannel Analyzers</i>	181	T29/p.228	NEW
N8315	NIM Linear Power supply 150W	<i>Modular Pulse Processing Electronics / Powered Crates</i>	176		
N840	8 Channel Leading Edge Discriminator	<i>Modular Pulse Processing Electronics / NIM</i>	129	T20/p.225	
N841	16 Channel Leading Edge Discriminator	<i>Modular Pulse Processing Electronics / NIM</i>	129	T20/p.225	
N842	8 Channel Constant Fraction Discriminator	<i>Modular Pulse Processing Electronics / NIM</i>	129	T20/p.225	
N843	16 Channel Constant Fraction Discriminator	<i>Modular Pulse Processing Electronics / NIM</i>	129	T20/p.225	
N844	8 Channel Low Threshold Discriminator	<i>Modular Pulse Processing Electronics / NIM</i>	129	T20/p.225	
N845	16 Channel Low Threshold Discriminator	<i>Modular Pulse Processing Electronics / NIM</i>	129	T20/p.225	
N858	Dual Attenuator	<i>Modular Pulse Processing Electronics / NIM</i>	127	T14/p.224	
N89	NIM - TTL - NIM Adapter	<i>Modular Pulse Processing Electronics / NIM</i>	131	T27/p.227	
N914	8 Fold Photomultiplier Pulse Processor	<i>Modular Pulse Processing Electronics / NIM</i>	122		
N93B	Dual Timer	<i>Modular Pulse Processing Electronics / NIM</i>	131	T26/p.227	
N957	8k Multichannel Analyzer	<i>Modular Pulse Processing Electronics / NIM</i>	122	T10/p.222	
N968	Spectroscopy Amplifier	<i>Modular Pulse Processing Electronics / NIM</i>	123	T13/p.224	
N978	4 Channel Variable Gain Fast Amplifier	<i>Modular Pulse Processing Electronics / NIM</i>	122	T12/p.223	
N979	16 Channel Fast Amplifier	<i>Modular Pulse Processing Electronics / NIM</i>	123	T12/p.223	
N979B	16 Channel Mixed Gain Fast Amplifier	<i>Modular Pulse Processing Electronics / NIM</i>	123	T12/p.223	
NDT1419	4 Ch Reversible 500 V/200 μ A NIM/Desktop HV Power Supply Module (USB/Ethernet/T.screen)	<i>Power Supplies / NIM High Voltage Power Supplies</i>	50	T6/p.220	
NDT1470	4 Ch Reversible 8 kV/3 mA (8 W) NIM/Desktop HV Power Supply Module (USB/Ethernet/T.screen)	<i>Power Supplies / NIM High Voltage Power Supplies</i>	50	T6/p.220	
NDT1471	4 Ch Reversible 5.5 kV/300 μ A NIM/Desktop HV Power Supply Module (USB/Ethernet/T.screen)	<i>Power Supplies / NIM High Voltage Power Supplies</i>	50	T6/p.220	
NDT1471H	4 Ch Reversible 5.5 kV/20 μ A NIM/Desktop HV Power Supply High Accuracy Module (USB/Ethernet/T.screen)	<i>Power Supplies / NIM High Voltage Power Supplies</i>	50	T6/p.220	
NDT6800	NIM/Desktop Digital Detector Emulator	<i>Digital Detector Emulators / NIM</i>	205		
NIM8301	7U 12 slot smart fan unit 300/600 W Crate	<i>Modular Pulse Processing Electronics / Powered Crates</i>	166	T9/p.222	
NIM8302	5U 10 slot 150 W Compact Crate	<i>Modular Pulse Processing Electronics / Powered Crates</i>	170	T9/p.222	
NIM8303	5U 12 slot 300/600 W Crate	<i>Modular Pulse Processing Electronics / Powered Crates</i>	168	T9/p.222	
NIM8304	7U 12 slot smart fan unit Switching 2000 W Crate	<i>Modular Pulse Processing Electronics / Powered Crates</i>	172	T9/p.222	
NIM8305	2 Slot Switching 430 W Mini Crate	<i>Modular Pulse Processing Electronics / Powered Crates</i>	171	T9/p.222	
NIM8306	2 Slot Switching 720 W Mini Crate	<i>Modular Pulse Processing Electronics / Powered Crates</i>	171	T9/p.222	
NV8020A	7U CRATE VME/NIM 8 slot VME64 365W, 5 slot NIM 150W	<i>Modular Pulse Processing Electronics / Powered Crates</i>	174	T9/p.222	
OPC Server	OPC Server for CAEN Power Supplies	<i>Power Supplies / Power Supply Control Software</i>	77		
R1419ET	8/4 Ch Reversible 500 V/200 μ A 19" HV Power Supply Module (USB/Ethernet/T.screen)	<i>Power Supplies / Standalone Power Supplies / Rack High Voltage Power Supplies</i>	61	T7/p.221	NEW
R1470ET	8/4 Ch Reversible 8 kV/3 mA (8 W) Desktop 19" Power Supply Module (USB/Ethernet/T.screen)	<i>Power Supplies / Standalone Power Supplies / Rack High Voltage Power Supplies</i>	61	T7/p.221	NEW

Product Index (continued)

Model	Description	Family	pp.	CRT	Status
R1471ET	8/4 Ch Reversible 5.5 kV/300 μ A Desktop 19" Power Supply Module (USB/Ethernet/T.screen)	Power Supplies / Standalone Power Supplies / Rack High Voltage Power Supplies	61	T7/p.221	NEW
R1471HET	8/4 Ch Reversible 5.5 kV/20 μ A 19" HV Power Supply High Accuracy Module (USB/Ethernet/T.screen)	Power Supplies / Standalone Power Supplies / Rack High Voltage Power Supplies	61	T7/p.221	NEW
R647	24 Channel Multipin Radial to SHV connector Adapter (Max: 8kV - 19" Rack)	Accessories / Adapters	46		
R648	48 Channel Radial to SHV connector Adapter (Max: 3kV - 19" Rack)	Accessories / Adapters	46		
R649	32 Channel Radial to SHV connector Adapter (Max: 3kV - 19" Rack)	Accessories / Adapters	46		
R649B	32 Channel Radial to SHV connector Adapter (Max: 8kV - 19" Rack)	Accessories / Adapters	46		
SP5600C - SP5600D SP5600E - SP5600AN	Nuclear and Modern Physics Kits	CAEN Educational	188		NEW
SP5600EMU	Emulation Kit	CAEN Educational	190		NEW
SP5700	EasyPET	CAEN Educational	189		COMING SOON
Sy Smart Touch	Control Software for SY4527 and SY5527 Systems	Power Supplies / Power Supply Control Software	75		
SY2791	Liquid Argon TPC Readout System	Readout Systems	192		
SY4527	Universal Multichannel Power Supply System / 19" wide, 8U-high (16 slot)	Power Supplies / Universal Multichannel Systems / Mainframes	16	T1/p.218	
SY4527LC	Universal Multichannel Power Supply System Low Cost / 19" wide, 8U-high (10 slot)	Power Supplies / Universal Multichannel Systems / Mainframes	20	T1/p.218	
SY5527	Universal Multichannel Power Supply System / 19" wide, 4U-high (6 slot)	Power Supplies / Universal Multichannel Systems / Mainframes	16	T1/p.218	
SY5527LC	Universal Multichannel Power Supply System Low Cost / 19" wide, 4U-high (4 slot)	Power Supplies / Universal Multichannel Systems / Mainframes	20	T1/p.218	
SY8800	Universal Multichannel Low Voltage Power Supply System	Power Supplies / High Power Low Voltage System	70	T1/p.218	
V1190A-2eSST	128 Channel Multihit TDC (100/200/800 ps)	Modular Pulse Processing Electronics / VME	145	T25/p.226	
V1190B-2eSST	64 Channel Multihit TDC (100/200/800 ps)	Modular Pulse Processing Electronics / VME	145	T25/p.226	
V1290A-2eSST	32 Channel Multihit TDC (25 ps)	Modular Pulse Processing Electronics / VME	146	T25/p.226	
V1290N-2eSST	16 Channel Multihit TDC (25 ps)	Modular Pulse Processing Electronics / VME	146	T25/p.226	
V1718	VME-USB2.0 Bridge	Modular Pulse Processing Electronics / VME	139	T19/p.225	
V1720	8 Channel 12-bit 250 MS/s Digitizer	Modular Pulse Processing Electronics / Waveform Digitizers / 720 Digitizer Family	90	T11/p.223	
V1724	8 Channel 14-bit 100 MS/s Digitizer	Modular Pulse Processing Electronics / Waveform Digitizers / 724 Digitizer Family	92	T11/p.223	
V1725	16/8 Channel 14-bit 250 MS/s Digitizer	Modular Pulse Processing Electronics / Waveform Digitizers / 725 Digitizer Family	94	T11/p.223	NEW
V1730	16/8 Channel 14-bit 500 MS/s Digitizer	Modular Pulse Processing Electronics / Waveform Digitizers / 730 Digitizer Family	96	T11/p.223	
V1740	64 Channel 12-bit 62.5 MS/s Digitizer	Modular Pulse Processing Electronics / Waveform Digitizers / 740 Digitizer Family	98	T11/p.223	
V1742	32+2 Channel 12-bit 5 GS/s Switched Capacitor Digitizer	Modular Pulse Processing Electronics / Waveform Digitizers / 742 Digitizer Family	104	T11/p.223	
V1743	16 Channel 12-bit 3.2 GS/s Switched Capacitor Digitizer	Modular Pulse Processing Electronics / Waveform Digitizers / 743 Digitizer Family	106	T11/p.223	
V1751	4-8 Channel 10-bit 2/1 GS/s Digitizer	Modular Pulse Processing Electronics / Waveform Digitizers / 751 Digitizer Family	100	T11/p.223	
V1761	2 Channel 10-bit 4GS/s Digitizer	Modular Pulse Processing Electronics / Waveform Digitizers / 761 Digitizer Family	102	T11/p.223	
V1785	8 Channel Dual Range Multievent Peak Sensing ADC	Modular Pulse Processing Electronics / VME	134	T10/p.222	
V2495	Programmable Logic Unit	Modular Pulse Processing Electronics / VME	136	T18/p.224	NEW
			136	T21/p.225	NEW
			136	T22/p.226	NEW
			136	T27/p.227	NEW
V2718	VME-PCI Optical Link Bridge	Modular Pulse Processing Electronics / VME	140	T19/p.225	
V538A	8 Channel NIM-ECL/ECL-NIM Translator	Modular Pulse Processing Electronics / VME	148	T27/p.227	

Product Index (continued)

Model	Description	Family	pp.	CRT	Status
V6519	6 Channel 500 V/3 mA VME HV Power Supply Module	Power Supplies / VME High Voltage Power Supplies	48	T5/p.220	
V6521	6 Channel 6 kV/300 μ A VME HV Power Supply Module	Power Supplies / VME High Voltage Power Supplies	48	T5/p.220	
V6521H	6 Channel 6 kV/20 μ A VME HV Power Supply Module	Power Supplies / VME High Voltage Power Supplies	48	T5/p.220	
V6533	6 Channel 4 kV/3 mA VME HV Power Supply Module (9 W)	Power Supplies / VME High Voltage Power Supplies	48	T5/p.220	
V6534	6 Channel 6 kV/1 mA VME HV Power Supply Module	Power Supplies / VME High Voltage Power Supplies	48	T5/p.220	
V775	32 Channel Multievent TDC (35 \pm 300 ps)	Modular Pulse Processing Electronics / VME	147	T25/p.226	
V775N	16 Channel Multievent TDC (35 \pm 300 ps)	Modular Pulse Processing Electronics / VME	147	T25/p.226	
V785	32 Channel Multievent Peak Sensing ADC	Modular Pulse Processing Electronics / VME	134	T10/p.222	
V785N	16 Channel Multievent Peak Sensing ADC	Modular Pulse Processing Electronics / VME	134	T10/p.222	
V792	32 Channel Multievent QDC	Modular Pulse Processing Electronics / VME	143	T23/p.226	
V792N	16 Channel Multievent QDC	Modular Pulse Processing Electronics / VME	143	T23/p.226	
V812	16 Channel Constant Fraction Discriminator	Modular Pulse Processing Electronics / VME	141	T20/p.225	
V814	16 Channel Low Threshold Discriminator	Modular Pulse Processing Electronics / VME	141	T20/p.225	
V830	32 Channel Latching Scaler	Modular Pulse Processing Electronics / VME	145	T24/p.226	
V859	Dual Attenuator	Modular Pulse Processing Electronics / VME	135	T14/p.224	
V862	32 Channel Multievent Individual Gate QDC	Modular Pulse Processing Electronics / VME	144	T23/p.226	
V895	16 Channel Leading Edge Discriminator	Modular Pulse Processing Electronics / VME	142	T20/p.225	
V925	Quad Linear Fan In-Fan Out	Modular Pulse Processing Electronics / VME	142	T21/p.225	
V965	16 Channel Dual Range Multievent QDC	Modular Pulse Processing Electronics / VME	144	T23/p.226	
V965A	8 Channel Dual Range Multievent QDC	Modular Pulse Processing Electronics / VME	144	T23/p.226	
V972	Delay Unit	Modular Pulse Processing Electronics / VME	147	T26/p.227	
V974	4 Channel Variable Gain Fast Amplifier	Modular Pulse Processing Electronics / VME	135	T12/p.223	
V975	8 Channel Fast Amplifier	Modular Pulse Processing Electronics / VME	135	T12/p.223	
V976	Quad 4 Fold AND/OR/MAJ, NIM-TTL TTLNIM Translator, Fan-In Fan-Out	Modular Pulse Processing Electronics / VME	138	T18/p.224	
			138	T21/p.225	
			138	T27/p.227	
V977	16 Channel I/O Register (Status A)	Modular Pulse Processing Electronics / VME	143	T22/p.226	
V993C	Dual Timer	Modular Pulse Processing Electronics / VME	148	T26/p.227	
VME8001	1U 2 Slot VME64 Mini Crate	Modular Pulse Processing Electronics / Powered Crates	163	T9/p.222	
VME8004B	2U 4 Slot VME64 Mini Crate	Modular Pulse Processing Electronics / Powered Crates	163	T9/p.222	
VME8004X	2U 4 Slot VME64X Mini Crate	Modular Pulse Processing Electronics / Powered Crates	164	T9/p.222	NEW
VME8008B	4U 8 Slot VME64 Mini Crate	Modular Pulse Processing Electronics / Powered Crates	164	T9/p.222	
VME8008X	4U 8 Slot VME64X Mini Crate	Modular Pulse Processing Electronics / Powered Crates	165	T9/p.222	NEW
VME8010 - VME8011	7U 21 Slot VME64 Low Cost Crates	Modular Pulse Processing Electronics / Powered Crates	162		
VME8100	8U 21 Slot VME64/64X Enhanced Crate series	Modular Pulse Processing Electronics / Powered Crates	158	T9/p.222	
VME8200	9U 21Slot VME64X Enhanced Crate series	Modular Pulse Processing Electronics / Powered Crates	160	T9/p.222	
VX1190A-2eSST	128 Channel Multihit TDC (100/200/800 ps)	Modular Pulse Processing Electronics / VME	145	T25/p.226	

Product Index (continued)

Model	Description	Family	pp.	CRT	Status
VX1190B-2eSST	64 Channel Multihit TDC (100/200/800 ps)	<i>Modular Pulse Processing Electronics / VME</i>	145	T25/p.226	
VX1290A-2eSST	32 Channel Multihit TDC (25 ps)	<i>Modular Pulse Processing Electronics / VME</i>	146	T25/p.226	
VX1290N-2eSST	16 Channel Multihit TDC (25 ps)	<i>Modular Pulse Processing Electronics / VME</i>	146	T25/p.226	
VX1718	VME-USB2.0 Bridge	<i>Modular Pulse Processing Electronics / VME</i>	139	T19/p.225	
VX1720	8 Channel 12-bit 250 MS/s Digitizer	<i>Modular Pulse Processing Electronics / Waveform Digitizers / 720 Digitizer Family</i>	90	T11/p.223	
VX1724	8 Channel 14-bit 100 MS/s Digitizer	<i>Modular Pulse Processing Electronics / Waveform Digitizers / 724 Digitizer Family</i>	92	T11/p.223	
VX1725	16/8 Channel 14-bit 250 MS/s Digitizer	<i>Modular Pulse Processing Electronics / Waveform Digitizers / 725 Digitizer Family</i>	94	T11/p.223	NEW
VX1730	16/8 Channel 14-bit 500 MS/s Digitizer	<i>Modular Pulse Processing Electronics / Waveform Digitizers / 730 Digitizer Family</i>	96	T11/p.223	
VX1740	64 Channel 12-bit 62.5 MS/s Digitizer	<i>Modular Pulse Processing Electronics / Waveform Digitizers / 740 Digitizer Family</i>	98	T11/p.223	
VX1742	32+2 Channel 12-bit 5 GS/s Switched Capacitor Digitizer	<i>Modular Pulse Processing Electronics / Waveform Digitizers / 742 Digitizer Family</i>	104	T11/p.223	
VX1743	16 Channel 12-bit 3.2 GS/s Switched Capacitor Digitizer	<i>Modular Pulse Processing Electronics / Waveform Digitizers / 743 Digitizer Family</i>	106	T11/p.223	
VX1751	4-8 Channel 10-bit 2/1 GS/s Digitizer	<i>Modular Pulse Processing Electronics / Waveform Digitizers / 751 Digitizer Family</i>	100	T11/p.223	
VX1761	2 Channel 10-bit 4GS/s Digitizer	<i>Modular Pulse Processing Electronics / Waveform Digitizers / 761 Digitizer Family</i>	102	T11/p.223	
VX2718	VME-PCI Optical Link Bridge	<i>Modular Pulse Processing Electronics / VME</i>	140	T19/p.225	
WaveCatcher	Advanced Software Tool for 743 Digitizers	<i>Modular Pulse Processing Electronics / Waveform Digitizers / Waveform Recording</i>	111		
WaveDump	Open Source Acquisition Software for Developers	<i>Modular Pulse Processing Electronics / Waveform Digitizers / Waveform Recording</i>	110		

Functional Index

Function	Family	Model	Description	pp.	CRT	Status
Adapters	<i>Accessories</i>	A1015	16 Floating Channel Multipin Radial to SHV connector Adapter for A1515 board (Max: 5 kV - Desktop)	46		
		A1015G	14/16 Stacked Channel Multipin Radial to SHV connector Adapter for A1515TG/A1515QG board (Max: 5 kV - Desktop)	46		
		A1481	Kill Signal Adapter for N14xx Series	208		
		A385 - A392	16 Channel LEMO Adapters	208		
		A318	Single-Ended to Differential Cable Adapter	211		
		A646	12 Channel DB37 to SHV connector Adapter (Max: 500V - Desktop)	46		
		A647	24 Channel Multipin Radial to SHV connector Adapter (Max: 8kV - Desktop)	46		
		A648	48 Channel Multipin Radial to SHV connector Adapter (Max: 3kV - Desktop)	46		
		A649	32 Channel Multipin Radial to SHV connector Adapter (Max: 3kV - Desktop)	46		
		A649B	32 Channel Multipin to SHV connector Adapter (Max: 8 kV - Desktop)	46		
		A654	MCX to LEMO Cable Adapters	208		
		A659	MCX to BNC Cable Adapters	208		
		A746B	64 Channel Adapter for LEMO Connector (VME)	209		
		A746D	32 Channel Adapter for LEMO Connector (NIM)	209		
		A746E	32 Channel Adapter for LEMO Connector (DT)	209		
		A954	16 Channel to 2x8 Channel Cable Adapter	209		
		A967	32 Channel Cable Adapter for V767, V862, V1190, VX1190, Vx495, DT5495	209		
		A992	16 Channel Impedance Adapter	209		
		N1568ADAT	USB RS485 Adapter Board	209		
		R647	24 Channel Multipin Radial to SHV connector Adapter (Max: 8kV - 19" Rack)	46		
		R648	48 Channel Radial to SHV connector Adapter (Max: 3kV - 19" Rack)	46		
		R649	32 Channel Radial to SHV connector Adapter (Max: 3kV - 19" Rack)	46		
		R649B	32 Channel Radial to SHV connector Adapter (Max: 8kV - 19" Rack)	46		
ADCs (Peak Sensing)	<i>NIM</i>	N957	8k Multichannel Analyzer	122	T10/p.222	
		<i>VME</i>	V1785	8 Channel Dual Range Multievent Peak Sensing ADC	134	T10/p.222
		V785	32 Channel Multievent Peak Sensing ADC	134	T10/p.222	
		V785N	16 Channel Multievent Peak Sensing ADC	134	T10/p.222	
Amplifiers (Fast)	<i>NIM</i>	N978	4 Channel Variable Gain Fast Amplifier	122	T12/p.223	
		N979	16 Channel Fast Amplifier	123	T12/p.223	
		N979B	16 Channel Mixed Gain Fast Amplifier	123	T12/p.223	
	<i>VME</i>	V974	4 Channel Variable Gain Fast Amplifier	135	T12/p.223	
		V975	8 Channel Fast Amplifier	135	T12/p.223	
Amplifiers (Spectroscopy)	<i>NIM</i>	N1068	16 Ch Programmable Spectroscopy Amplifier with Time Filter, CFD and pile-up rejection	124	T13/p.224	NEW
		N1168	16 Ch Fast Scintillator Programmable Signal Processor and 16 ch CFD	125		COMING SOON
		N1568A	16 Ch Programmable Spectroscopy Amplifier & Dual 16 Ch CFD (30%; 80%)	126	T13/p.224	
		N568E	16 Channel Programmable Spectroscopy Amplifier (Low Noise)	128	T13/p.224	
		N568EB	16 Channel Programmable Spectroscopy Amplifier (Low Noise)	128		
		N568ELC	16 Channel Programmable Spectroscopy Amplifier	128	T13/p.224	
		N968	Spectroscopy Amplifier	123	T13/p.224	
Analog Multiplexed ASICs Readout Systems	<i>Readout Systems</i>	DT5550	32 Channel DAQ System with Programmable FPGA and Sequencer	196		COMING SOON
Analog Pulse Processors	<i>NIM</i>	N914	8 Fold Photomultiplier Pulse Processor	122		

Functional Index (continued)

Function	Family	Model	Description	pp.	CRT	Status	
Attenuators	<i>NIM</i>	N858	Dual Attenuator	127	T14/p.224		
	<i>VME</i>	V859	Dual Attenuator	135	T14/p.224		
Cables	<i>Accessories</i>	A317	Clock Distribution Cable	211			
		Al2700	Optical Fiber Series	210			
Charge Sensitive Preamplifiers	<i>Preamplifiers</i>	A1422	Low Noise Fast Rise Time Charge Sensitive Preamplifiers	151	T15/p.224		
		A1422H	Low Noise Fast Rise Time Charge Sensitive Preamplifiers (Hybrid)	150	T15/p.224		
		A422A	Charge Sensitive Preamplifier with Timing	150	T15/p.224		
Charge Sensitive Preamplifiers (Scintillation Detectors)	<i>Preamplifiers</i>	A1424	Scintillation Preamplifier	152	T16/p.224		
Coincidence/Logic/Trigger Units	<i>NIM</i>	N113	Dual OR 12 In - 2 Out	127	T18/p.224		
		N405	Triple 4-Fold Logic Unit/Majority with VETO	127	T18/p.224		
		N455	Quad Coincidence Logic Unit	128	T18/p.224		
	<i>VME</i>	A395A	32 LVDS/ECL/PECL input channels (Piggyback board)	137			
		A395B	32 LVDS output channels (Piggyback board)	137			
		A395C	32 ECL output channels (Piggyback board)	137			
		A395D	8 NIM/TTL input/output channels (Piggyback board)	137			
		A395E	8 Analog output 16-bit channels (Piggyback board)	137			
		V2495	Programmable Logic Unit	136	T18/p.224	NEW	
		V976	Quad 4 Fold AND/OR/MAJ, NIM-TTL TTLNIM Translator, Fan-In Fan-Out	138	T18/p.224		
	Common Floating Return Boards	<i>Power Supplies</i>	A1523	6 Channel 12 kV/1 mA Common Floating Return Board	42	T4/p.219	
			A1524	6 Channel 12 kV/100 μ A Common Floating Return Board	42	T4/p.219	
			A1526	6 Channel 15 kV, 1/0.1 mA Common Floating Return Board	44	T4/p.219	
A1535			12/24 Channel 3.5 kV/3 mA (9 W) Common Floating Return Boards	33	T4/p.219		
A1536			12/24/32 Channel 3 kV/1 mA Common Floating Return Boards	33	T4/p.219		
A1538D			12 Channel 1.5 kV/10 mA (12W) Common Floating Return Board	33	T4/p.219		
A1539			12/24/32 Channel 100 V/15 mA Common Floating Return Boards	28	T4/p.219	NEW	
A1540			12/24/32 Channel 100 V/1 mA Common Floating Return Boards	28	T4/p.219	NEW	
A1540H			12/24/32 Channel 100 V, 15 mA/20 μ A Common Floating Return Dual Range Boards	28	T4/p.219	NEW	
A1541			12/24/32 Channel 500 V/10 mA Common Floating Return Boards	28	T4/p.219	NEW	
A1542			12/24/32 Channel 500 V/1 mA Common Floating Return Boards	28	T4/p.219	NEW	
A1542H			12/24/32 Channel 500 V, 10 mA/20 μ A Common Floating Return Dual Range Boards	28	T4/p.219	NEW	
A1550			12/24/32 5 kV/1 mA Common Floating Return Boards	39	T4/p.219		
A1560H			8/16 Channel 6 kV/20 μ A Common Floating Return Boards	41	T4/p.219	NEW	
A1561H			12 Channel 6 kV/20 μ A Common Floating Return Board	39	T4/p.219		
A1580H			8/16 Channel 8 kV/20 μ A Common Floating Return Boards	41	T4/p.219	NEW	
A1588			8 Channel \pm 2 kV/500 μ A 4 Quadrant Bipolar Board	45			
A1590			16 Channel 9 kV/100 μ A Common Floating Return Board	42	T4/p.219	NEW	
A7030			12/24/36/48 Channel 3 kV/1 mA (1.5W) Common Floating Return Boards	36	T4/p.219	NEW	
A7040			12/24/36/48 Channel 100 V/500 μ A Common Floating Return Boards	31	T4/p.219	COMING SOON	
A7042			12/24/36/48 Channel 500 V/500 μ A Common Floating Return Boards	31	T4/p.219	NEW	
A7236			32 Channel 3.5 kV/1.5 mA (4W) Common Floating Return Board	38	T4/p.219	NEW	
A7435			24 Channel 3.5 kV/3.5 mA (9W) Common Floating Return Board	38	T4/p.219	NEW	

Functional Index (continued)

Function	Family	Model	Description	pp.	CRT	Status
Common Floating Return Boards	<i>Power Supplies</i>	AP932	1 Channel 3 kV/30mA Individual Floating Board (SHV conn)	33	T2/p.218	
Common Ground Boards	<i>Power Supplies</i>	A1821	12 Channel 3 kV, 200/20 μ A Common Ground Dual Range Board	33	T3/p.219	
		A1821H	12 Channel 3 kV, 200/10 μ A Common Ground Dual Range Board	33	T3/p.219	
		A1833	12 Channel 3 kV/3mA, 4 kV/2 mA, 4 kV/0.2 mA Common Ground Dual Range Board	33	T3/p.219	
		AG523	6 Channel 12 kV/1 mA Common Ground Board	42	T3/p.219	
		AG524	6 Channel 12 kV/100 μ A Common Ground Board	42	T3/p.219	
		AG535	12/24 Channel 3.5 kV/3 mA (6 W) Common Ground Boards	33	T3/p.219	
		AG536	12/24/32 Channel 3 kV/1 mA Common Ground Boards	33	T3/p.219	
		AG538D	12 Channel 1.5 kV/10 mA (12W) Common Ground Board	33	T3/p.219	
		AG539	12/24/32 Channel 100 V/15 mA Common Ground Boards	28	T3/p.219	NEW
		AG540	12/24/32 Channel 100 V/1 mA Common Ground Boards	28	T3/p.219	NEW
		AG541	12/24/32 Channel 500 V/10 mA Common Ground Boards	28	T3/p.219	NEW
		AG542	12/24/32 Channel 500 V/1 mA Common Ground Boards	28	T3/p.219	NEW
		AG550	12/24/32 Channel 5 kV/1 mA Common Ground Boards	39	T3/p.219	
		AG590	16 Channel 9 kV/100 μ A Common Ground Board	42	T3/p.219	NEW
		AG7030	12/24/36/48 Channel 3 kV/1 mA (1.5W) Common Ground Boards	36	T3/p.219	NEW
		AG7040	12/24/36/48 Channel 100 V/500 μ A Common Ground Boards	31	T3/p.219	COMING SOON
		AG7042	12/24/36/48 Channel 500 V/500 μ A Common Ground Boards	31	T3/p.219	NEW
		AG7236	32 Channel 3.5 kV/1.5 mA (4W) Common Ground Board	38	T3/p.219	NEW
		AG7435	24 Channel 3.5 kV/3.5 mA (9W) Common Ground Board	38	T3/p.219	NEW
Configuration Tools	<i>Waveform Digitizers</i>	CAEN SyncTest	Demo Software for CAEN Digitizers Synchronization	120		
		CAEN VME Demos	Demo Applications for CAEN Bridges Control	120		
		CAENUpgrader	Firmware Upgrade Tool for Front-end Boards Bridges & VME Power Supply	120		
Control Software	<i>Power Supplies</i>	GECO2020	General Control Software for CAEN HV Power Supplies	72		
		HiVoCS	Web based Control Software for SY4527 and SY5527 Systems	74		
		Sy Smart Touch	Control Software for SY4527 and SY5527 Systems	75		
Controllers	<i>VME</i>	V1718	VME-USB2.0 Bridge	139	T19/p.225	
		V2718	VME-PCI Optical Link Bridge	140	T19/p.225	
		VX1718	VME-USB2.0 Bridge	139	T19/p.225	
		VX2718	VME-PCI Optical Link Bridge	140	T19/p.225	
Desktop High Voltage Power Supplies	<i>Power Supplies</i>	DT1419ET	4 Ch Reversible 500 V/200 μ A Desktop HV Power Supply Module (USB/Ethernet/T.screen)	58	T7/p.221	NEW
		DT1470ET	4 Ch Reversible 8 kV/3 mA (8 W) Desktop HV Power Supply Module (USB/Ethernet/T.screen)	58	T7/p.221	NEW
		DT1471ET	4 Ch Reversible 5.5 kV/300 μ A Desktop HV Power Supply Module (USB/Ethernet/T.screen)	58	T7/p.221	NEW
		DT1471HET	4 Ch Reversible 5.5 kV/20 μ A Desktop HV Power Supply High Accuracy Module (USB/Ethernet/T.screen)	58	T7/p.221	NEW
		DT5470	1 Ch 5 kV/200 μ A USB-Powered Desktop HV Power Supply	59	T7/p.221	NEW
		DT5471	1 Ch 3 kV/500 μ A (1 W) USB-Powered Desktop HV Power Supply	59	T7/p.221	NEW
		DT5472	1 Ch 500 V/1 mA USB-Powered Desktop HV Power Supply	59	T7/p.221	NEW
		DT5519E	4 Channel 500 V/3 mA Desktop HV Power Supply Module (USB/Ethernet)	56	T7/p.221	NEW
		DT5521E	4 Channel 6 kV/300 μ A Desktop HV Power Supply Module (USB/Ethernet)	56	T7/p.221	NEW
		DT5521HE	4 Channel 6 kV/20 μ A Desktop HV Power Supply Module (USB/Ethernet)	56	T7/p.221	NEW

Functional Index (continued)

Function	Family	Model	Description	pp.	CRT	Status
Desktop High Voltage Power Supplies	<i>Power Supplies</i>	DT5533E	4 Channel 4 kV/3 mA (4 W) Desktop HV Power Supply Module (USB/Ethernet)	56	T7/p.221	NEW
		DT5534E	4 Channel 6 kV/1 mA (4 W) Desktop HV Power Supply Module (USB/Ethernet)	56	T7/p.221	NEW
		R1419ET	8/4 Ch Reversible 500 V/200 μ A 19" HV Power Supply Module (USB/Ethernet/T.screen)	61	T7/p.221	NEW
		R1470ET	8/4 Ch Reversible 8 kV/3 mA (8 W) Desktop 19" Power Supply Module (USB/Ethernet/T.screen)	61	T7/p.221	NEW
		R1471ET	8/4 Ch Reversible 5.5 kV/300 μ A Desktop 19" Power Supply Module (USB/Ethernet/T.screen)	61	T7/p.221	NEW
		R1471HET	8/4 Ch Reversible 5.5 kV/20 μ A 19" HV Power Supply High Accuracy Module (USB/Ethernet/T.screen)	61	T7/p.221	NEW
Desktop Low Voltage Power Supplies	<i>Power Supplies</i>	DT5423	Quad Desktop Power distributor	60		
	<i>Preamplifiers</i>	DT5423	Quad Desktop Power distributor	154		
Digital Detector Emulators	<i>Desktop</i>	DT4800	Micro Digital Detector Emulator	204		NEW
		DT5800	Desktop Digital Detector Emulator	205		
		DT5810	Desktop Fast Digital Detector Emulator	203		NEW
	<i>NIM</i>	NDT6800	NIM/Desktop Digital Detector Emulator	205		
Digital Pulse Processing firmware	<i>Readout Systems</i>	DPP-CRAMS	Digital Pulse Processing for CAEN Readout of Analog Multiplexed Signals (x724)	195		
		FW1495CRAMS	Sequencer firmware for CAEN Readout of Analog Multiplexed Signals (V1495)	195		
	<i>VME</i>	FW495SC	128 Ch Multievent Latching Scaler	138		
	<i>Waveform Digitizers / DPP</i>	DPP-DAW	Channel Independent Zero Suppression with Dynamic Acquisition Window	117		NEW
		DPP-PHA	DPP-PHA - Digital Pulse Processing for Pulse Height Analysis	113		
		DPP-PSD	Digital Charge Integration and Pulse Shape Analysis	114		
		DPP-QDC	Digital Charge to Digital Converter for 740 Digitizer	115		NEW
		DPP-ZLEplus	Advanced Zero Length Encoding	116		
Digital Pulse Shape Discriminators	<i>Digital Spectroscopy</i>	DT5790	Dual Digital Pulse Shape Discriminator	183		
Digitizers	<i>720 Family</i>	DT5720	4/2 Channel 12-bit 250 MS/s Digitizer	90	T11/p.223	
		N6720	2/4 Channel 12-bit 250 MS/s Digitizer	90	T11/p.223	
		V1720	8 Channel 12-bit 250 MS/s Digitizer	90	T11/p.223	
		VX1720	8 Channel 12-bit 250 MS/s Digitizer	90	T11/p.223	
	<i>724 Family</i>	DT5724	4/2 Channel 14-bit 100 MS/s Digitizer	92	T11/p.223	
		N6724	4/2 Channel 14-bit 100 MS/s Digitizer	92	T11/p.223	
		V1724	8 Channel 14-bit 100 MS/s Digitizer	92	T11/p.223	
		VX1724	8 Channel 14-bit 100 MS/s Digitizer	92	T11/p.223	
	<i>725 Family</i>	DT5725	8 Channel 14-bit 250 MS/s Digitizer	94	T11/p.223	NEW
		N6725	8 Channel 14-bit 250 MS/s Digitizer	94	T11/p.223	NEW
		V1725	16/8 Channel 14-bit 250 MS/s Digitizer	94	T11/p.223	NEW
		VX1725	16/8 Channel 14-bit 250 MS/s Digitizer	94	T11/p.223	NEW
	<i>730 Family</i>	DT5730	8 Channel 14-bit 500 MS/s Digitizer	96	T11/p.223	
		N6730	8 Channel 14-bit 500 MS/s Digitizer	96	T11/p.223	
		V1730	16/8 Channel 14-bit 500 MS/s Digitizer	96	T11/p.223	
		VX1730	16/8 Channel 14-bit 500 MS/s Digitizer	96	T11/p.223	
	<i>740 Family</i>	DT5740	32 Channel 12-bit 62.5MS/s Digitizer	98	T11/p.223	
		N6740	32 Channel 12-bit 62.5 MS/s Digitizer	98	T11/p.223	
		V1740	64 Channel 12-bit 62.5 MS/s Digitizer	98	T11/p.223	
		VX1740	64 Channel 12-bit 62.5 MS/s Digitizer	98	T11/p.223	

Functional Index (continued)

Function	Family	Model	Description	pp.	CRT	Status
Digitizers	742 Family	DT5742	16+1 Channel 12-bit 5 GS/s Switched Capacitor Digitizer	104	T11/p.223	
		N6742	16+1 Channel 12-bit 5 GS/s Switched Capacitor Digitizer	104	T11/p.223	
		V1742	32+2 Channel 12-bit 5 GS/s Switched Capacitor Digitizer	104	T11/p.223	
		VX1742	32+2 Channel 12-bit 5 GS/s Switched Capacitor Digitizer	104	T11/p.223	
	743 Family	DT5743	8 Channel 12-bit 3.2 GS/s Switched Capacitor Digitizer	106	T11/p.223	
		N6743	8 Channel 12-bit 3.2 GS/s Switched Capacitor Digitizer	106	T11/p.223	
		V1743	16 Channel 12-bit 3.2 GS/s Switched Capacitor Digitizer	106	T11/p.223	
		VX1743	16 Channel 12-bit 3.2 GS/s Switched Capacitor Digitizer	106	T11/p.223	
	751 Family	DT5751	2-4 Channel 10-bit 2/1 GS/s Digitizer	100	T11/p.223	
		N6751	2-4 Channel 10-bit 2/1 GS/s Digitizer	100	T11/p.223	
		V1751	4-8 Channel 10-bit 2/1 GS/s Digitizer	100	T11/p.223	
		VX1751	4-8 Channel 10-bit 2/1 GS/s Digitizer	100	T11/p.223	
	761 Family	DT5761	1 Channel 10-bit 4 GS/s Digitizer	102	T11/p.223	
		N6761	1 Channel 10-bit 4 GS/s Digitizer	102	T11/p.223	
		V1761	2 Channel 10-bit 4GS/s Digitizer	102	T11/p.223	
		VX1761	2 Channel 10-bit 4GS/s Digitizer	102	T11/p.223	
Discriminators	NIM	N605	4 Channel 200 MHz Constant Fraction Discriminator	128	T20/p.225	NEW
		N840	8 Channel Leading Edge Discriminator	129	T20/p.225	
		N841	16 Channel Leading Edge Discriminator	129	T20/p.225	
		N842	8 Channel Constant Fraction Discriminator	129	T20/p.225	
		N843	16 Channel Constant Fraction Discriminator	129	T20/p.225	
		N844	8 Channel Low Threshold Discriminator	129	T20/p.225	
		N845	16 Channel Low Threshold Discriminator	129	T20/p.225	
	VME	V812	16 Channel Constant Fraction Discriminator	141	T20/p.225	
		V814	16 Channel Low Threshold Discriminator	141	T20/p.225	
		V895	16 Channel Leading Edge Discriminator	142	T20/p.225	
EASY Bulk Power Supplies	Power Supplies	A348x	EASY3000 AC/DC Converters	66		
EASY Crates	Power Supplies	EASY3000x	EASY3000 Remote Crates	66		
EASY Fan Units	Power Supplies	A3000Fx	EASY3000 Fan Units	66		
EASY Power Supply Boards	Power Supplies	A30xx - A3602	EASY3000 LV Floating Power Supply Boards	66		
		A3100x	EASY3000 LV Floating Power Supply Boards	66		
		A35xx	EASY3000 HV Power Supply Boards	66		
EASY Front-End Boards	Power Supplies	A380x	128 Channel ADC/DAC/Temperature Sensor Boards	66		
EASY Remote Controllers	Power Supplies	A1676A	EASY3000 Branch Controller	66		
Educational Kits (Detector Emulation)	CAEN Educational	SP5600EMU	Emulation Kit	190		NEW
Educational Kits (PET System)	CAEN Educational	SP5700	EasyPET	189		COMING SOON
Educational Kits (SiPM)	CAEN Educational	SP5600C - SP5600D SP5600E - SP5600AN	Nuclear and Modern Physics Kits	188		NEW
EPICS Input-Output Controller	Power Supplies	EPICS IOC (PSM)	EPICS IOC for Power Supply Modules	78		
		EPICS IOC (SY4527 / SY5527)	EPICS IOC for SY4527 and SY5527 Systems	78		
Fan In-Fan Out Units	NIM	N454	4 - 8 Logic Fan In-Fan Out	130	T21/p.225	
		N625	Quad Linear Fan In-Fan Out	130	T21/p.225	
	VME	V2495	Programmable Logic Unit	136	T21/p.225	NEW
		V925	Quad Linear Fan In-Fan Out	142	T21/p.225	

Functional Index (continued)

Function	Family	Model	Description	pp.	CRT	Status
Fan In-Fan Out Units	VME	V976	Quad 4 Fold AND/OR/MAJ, NIM-TTL TTLNIM Translator, Fan-In Fan-Out	138	T21/p.225	
Fan Units	Accessories	A83xx	General Purpose 1U Fan Unit	211		NEW
	Powered Crates	A83xx	General Purpose 1U Fan Unit	176		NEW
Fast Preamplifiers	Preamplifiers	A1425	Fast Charge Preamplifier	152	T17/p.224	NEW
		A1426 CARDARELLI	Matched Preamplifier	153	T17/p.224	COMING SOON
Fixed Attenuators	Accessories	A309 - A310 - A311 - A312 A313	Single Channel Fixed Attenuators	210		
HV Connectors	Accessories	A995	Insertion/Extraction Tool for A996	210		
		A996	52 Pin Cable Connector	210		
		A997	HV Coaxial Cable Connector for CPE HV	210		
HV Filter	Accessories	A483	HV Bidirectional Passive HV Filter	210		
I/O Registers	VME	V2495	Programmable Logic Unit	136	T22/p.226	NEW
		V977	16 Channel I/O Register (Status A)	143	T22/p.226	
Individual Floating Channel Boards	Power Supplies	A1510	12 Channel 100 V, 1/10 mA Individual Floating Channel Dual Range Board	32	T2/p.218	
		A1511B	12 Channel 500 V, 1/10 mA Individual Floating Channel Dual Range Board	32	T2/p.218	
		A1512	12 Channel 500 V, 1 mA/100 μ A Individual Floating Channel Dual Range Board	32	T2/p.218	
		A1513B	6 Channel 10 V/2.7 A Individual Floating Channel Board	27	T2/p.218	
		A1515	16 Channel Floating 1kV, 1/0.1 mA Board	37	T2/p.218	NEW
		A1515QG	16 Channel Floating 1kV, 1/0.1 mA Board for Quadruple GEM detectors	37	T2/p.218	NEW
		A1515TG	14 Channel Floating 1kV, 1/0.1 mA Board for Triple GEM detectors	37	T2/p.218	NEW
		A1516B	6 Channel 15 V/1.5 A Individual Floating Channel Board	27	T2/p.218	
		A1517B	6 Channel 7 V/4 A Individual Floating Channel Board	27	T2/p.218	
		A1518B	6 Channel 4.5 V/6 A Individual Floating Channel Board	27	T2/p.218	
		A1519B	12 Channel 250 V, 0.1/1 mA Individual Floating Channel Dual Range Board	32	T2/p.218	
		A1520P	12 Channel 500 V/15 mA Individual Floating Channel Board	32	T2/p.218	
		A1534	12 Channel 8 kV/200 μ A Individual Floating Channel Board	39	T2/p.218	
		A2517	8 Channel 5 V/15 A (50 W) Individual Floating Channel Board	27	T2/p.218	
		A2518	8 Channel 8 V/10 A (50 W) Individual Floating Channel Boards	27	T2/p.218	
		A2519	8 Channel 15V/5 A (50 W) Individual Floating Channel Boards	27	T2/p.218	
LabVIEW Instrument Driver	Power Supplies	LabVIEW Driver	Instrument Driver for Power Supply Modules	76		
Liquid Argon TPC Readout System	Readout Systems	A2795	Liquid Argon TPC Readout Board	194		NEW
		SY2791	Liquid Argon TPC Readout System	192		
Mainframes	Power Supplies	A4528x	SY4527/SY5527 CPU Modules	21		
		A4531	SY4527/SY5527 Primary Power Supply 600 W	21		
		A4532	SY4527/SY5527 Optional Single Power Supply Unit 600 W	21		
		A4533	SY4527/SY5527 Optional Single Power Supply Unit 1200 W	21		
		SY4527	Universal Multichannel Power Supply System / 19" wide, 8U-high (16 slot)	16	T1/p.218	
		SY4527LC	Universal Multichannel Power Supply System Low Cost / 19" wide, 8U-high (10 slot)	20	T1/p.218	
		SY5527	Universal Multichannel Power Supply System / 19" wide, 4U-high (6 slot)	16	T1/p.218	
		SY5527LC	Universal Multichannel Power Supply System Low Cost / 19" wide, 4U-high (4 slot)	20	T1/p.218	
SY8800	Universal Multichannel Low Voltage Power Supply System	70	T1/p.218			
Multichannel Analyzer	Digital Spectroscopy	DT5770	Digital Multichannel Analyzer - Desktop	182	T28/p.227	NEW

Functional Index

Function	Family	Model	Description	pp.	CRT	Status
Multichannel Analyzer	<i>Digital Spectroscopy</i>	DT5780	Dual Digital Multichannel Analyzer (HV & Preamplifier PS) - Desktop	179	T28/p.227	
		DT5781	Dual/Quad Digital Multichannel Analyzer - Desktop	181	T28/p.227	NEW
		Gamma stream	Active, stand-alone, fully featured MCA tube base for scintillation	184	T28/p.227	NEW
		HEXAGON	Dual Digital Multichannel Analyzer (HV & Preamplifier PS - LCD) - Desktop	178		COMING SOON
		N6780	Dual Digital Multichannel Analyzer (HV & Preamplifier PS) - NIM	179	T29/p.228	
		N6781	Dual/Quad Digital Multichannel Analyzer - NIM	181	T29/p.228	NEW
Mixed Powered Crates	<i>Powered Crates</i>	NV8020A	7U CRATE VME/NIM 8 slot VME64 365W, 5 slot NIM 150W	174	T9/p.222	
NIM High Voltage Power Supplies	<i>Power Supplies</i>	N1419/A/B	4/2/1 Ch Reversible 500 V/200 μ A NIM HV Power Supply Module (USB)	50	T6/p.220	
		N1419ET	4 Ch Reversible 500 V/200 μ A NIM HV Power Supply Module (USB/Ethernet/Tscreen)	50	T6/p.220	
		N1470/A/B	4/2/1 Ch Reversible 8 kV/3 mA (8 W) NIM HV Power Supply Module (USB)	50	T6/p.220	
		N1470AL	2 Ch Reversible 8 kV/3 mA (8 W) NIM HV Power Supply Module Low Cost Locally Programmable	50	T6/p.220	
		N1470AR	2 Ch Reversible 8 kV/3 mA (8 W) NIM HV Power Supply Module (USB) Low Cost Remotely Programmable	50	T6/p.220	
		N1470ET	4 Ch Reversible 8 kV/3 mA (8 W) NIM HV Power Supply Module (USB/Ethernet/T screen)	50	T6/p.220	
		N1471/A/B	4/2/1 Ch Reversible 5.5 kV/300 μ A NIM HV Power Supply Module (USB)	50	T6/p.220	
		N1471ET	4 Ch Reversible 5.5 kV/300 μ A NIM HV Power Supply Module (USB/Ethernet/T screen)	50	T6/p.220	
		N1471H/A/B	4/2/1 Ch Reversible 5.5 kV/20 μ A NIM HV Power Supply High Accuracy Module (USB)	50	T6/p.220	
		N1471HET	4 Ch Reversible 5.5 kV/20 μ A NIM HV Power Supply High Accuracy Module (USB/Ethernet/T.screen)	50	T6/p.220	
		N1570	2 Channel 15 kV/1 mA (10 W) NIM HV Power Supply Module (USB/Ethernet/T.screen)	53	T6/p.220	NEW
		N472	4 Channel 6 kV Power Supply	52	T6/p.220	
		NDT1419	4 Ch Reversible 500 V/200 μ A NIM/Desktop HV Power Supply Module (USB/Ethernet/T.screen)	50	T6/p.220	
		NDT1470	4 Ch Reversible 8 kV/3 mA (8 W) NIM/Desktop HV Power Supply Module (USB/Ethernet/T.screen)	50	T6/p.220	
		NDT1471	4 Ch Reversible 5.5 kV/300 μ A NIM/Desktop HV Power Supply Module (USB/Ethernet/T.screen)	50	T6/p.220	
		NDT1471H	4 Ch Reversible 5.5 kV/20 μ A NIM/Desktop HV Power Supply High Accuracy Module (USB/Ethernet/T.screen)	50	T6/p.220	
NIM Low Voltage Power Supplies	<i>Power Supplies</i>	N5424	Quad NIM Power distributor	54		
	<i>Preamplifiers</i>	N5424	Quad NIM Power distributor	154		
NIM Powered Crates	<i>Powered Crates</i>	NIM8301	7U 12 slot smart fan unit 300/600 W Crate	166	T9/p.222	
		NIM8302	5U 10 slot 150 W Compact Crate	170	T9/p.222	
		NIM8303	5U 12 slot 300/600 W Crate	168	T9/p.222	
		NIM8304	7U 12 slot smart fan unit Switching 2000 W Crate	172	T9/p.222	
		NIM8305	2 Slot Switching 430 W Mini Crate	171	T9/p.222	
		NIM8306	2 Slot Switching 720 W Mini Crate	171	T9/p.222	
NIM Powered Crates - Accessories	<i>Powered Crates</i>	N8315	NIM Linear Power supply 150W	176		
Optical Controllers	<i>Accessories</i>	A2818	PCI CONET Controller	208	T19/p.225	
		A3818	PCI Express CONET2 Controller	208	T19/p.225	
PCB High Voltage Power Supplies	<i>Power Supplies</i>	A7501	1 Ch 2100 V/100 μ A High Efficiency HV Power Supply Module	62	T8/p.221	NEW
		A7501PB	Single Channel High Reliability, High Voltage Power Supply Box	64		NEW
		A7504	1 Ch 4000 V/100 μ A High Efficiency HV Power Supply Module	62	T8/p.221	NEW
		A7505	1 Ch 1600 V/500 μ A High Efficiency HV Power Supply Module	62	T8/p.221	NEW
		A7508	1 Ch 800V/50 μ A High Efficiency HV Power Supply Module	62	T8/p.221	NEW
		A7560	2 Ch Bipolar \pm 6kV/10 μ A High Performance HV Power Supply Module	63	T8/p.221	NEW

Functional Index (continued)

Function	Family	Model	Description	pp.	CRT	Status
Power Supply Control Software	<i>Power Supplies</i>	OPC Server	OPC Server for CAEN Power Supplies	77		
QDCs	<i>VME</i>	V792	32 Channel Multievent QDC	143	T23/p.226	
		V792N	16 Channel Multievent QDC	143	T23/p.226	
		V862	32 Channel Multievent Individual Gate QDC	144	T23/p.226	
		V965	16 Channel Dual Range Multievent QDC	144	T23/p.226	
		V965A	8 Channel Dual Range Multievent QDC	144		
Readout Software - DPP	<i>Waveform Digitizers</i>	CoMPASS	Multiparametric DAQ Software for Physics Applications	112		NEW
		DPP-DAW Demo Software	Software interface for DPP-DAW management	117		NEW
		DPP-PSD Control Software	Graphical Interface for DPP-PSD Management	114		
		DPP-QDC Demo Software	Software interface for DPP-QDC management	115		NEW
		DPP-ZLEplus Demo Software	Software interface for DPP-ZLEplus management	116		
		MC Analyzer	User Friendly Software for Digital Pulse Height Analysis	113		
Readout Software - Waveform Recording	<i>Waveform Digitizers</i>	CAENScope	CAEN Digitizer Signal Inspection and Waveform Recording Software	109		
		WaveCatcher	Advanced Software Tool for 743 Digitizers	111		
		WaveDump	Open Source Acquisition Software for Developers	110		
Scalers	<i>NIM</i>	N1145	Quad Scaler and Preset Counter / Timer	130	T24/p.226	
	<i>VME</i>	V830	32 Channel Latching Scaler	145	T24/p.226	
SiPM arrays Readout System	<i>Readout Systems</i>	A1702	32 Channel Silicon Photomultipliers Readout Front-End Board	197		NEW
Software Libraries	<i>Power Supplies</i>	CAEN HV Wrapper	Library for CAEN Power Supply Control	73		
	<i>Waveform Digitizers</i>	CAENComm	Interface Library for CAEN Data Acquisition Modules	119		
		CAENDigitizer	Library of Functions for CAEN Digitizers High Level Management	119		
		CAENDPP	High Level Library for CAEN Boards Running DPP Firmware	119		
Splitter	<i>Accessories</i>	A315	Splitter	211		
TDCs	<i>VME</i>	V1190A-2eSST	128 Channel Multihit TDC (100/200/800 ps)	145	T25/p.226	
		V1190B-2eSST	64 Channel Multihit TDC (100/200/800 ps)	145	T25/p.226	
		V1290A-2eSST	32 Channel Multihit TDC (25 ps)	146	T25/p.226	
		V1290N-2eSST	16 Channel Multihit TDC (25 ps)	146	T25/p.226	
		V775	32 Channel Multievent TDC (35÷300 ps)	147	T25/p.226	
		V775N	16 Channel Multievent TDC (35÷300 ps)	147	T25/p.226	
		VX1190A-2eSST	128 Channel Multihit TDC (100/200/800 ps)	145	T25/p.226	
		VX1190B-2eSST	64 Channel Multihit TDC (100/200/800 ps)	145	T25/p.226	
		VX1290A-2eSST	32 Channel Multihit TDC (25 ps)	146	T25/p.226	
		VX1290N-2eSST	16 Channel Multihit TDC (25 ps)	146	T25/p.226	
		Timing Units	<i>NIM</i>	N108A	Dual Delay	131
N93B	Dual Timer			131	T26/p.227	
<i>VME</i>	V972		Delay Unit	147	T26/p.227	
	V993C		Dual Timer	148	T26/p.227	
Translators	<i>NIM</i>	N638	16 Channel NIM-ECL/ECL-NIM Translator and Fan Out	132	T27/p.227	
		N89	NIM - TTL - NIM Adapter	131	T27/p.227	
	<i>VME</i>	V2495	Programmable Logic Unit	136	T27/p.227	NEW
		V538A	8 Channel NIM-ECL/ECL-NIM Translator	148	T27/p.227	
		V976	Quad 4 Fold AND/OR/MAJ, NIM-TTL TTLNIM Translator, Fan-In Fan-Out	138	T27/p.227	

Functional Index (continued)

Function	Family	Model	Description	pp.	CRT	Status
VME High Voltage Power Supplies	<i>Power Supplies</i>	V6519	6 Channel 500 V/3 mA VME HV Power Supply Module	48	T5/p.220	
		V6521	6 Channel 6 kV/300 μ A VME HV Power Supply Module	48	T5/p.220	
		V6521H	6 Channel 6 kV/20 μ A VME HV Power Supply Module	48	T5/p.220	
		V6533	6 Channel 4 kV/3 mA VME HV Power Supply Module (9 W)	48	T5/p.220	
		V6534	6 Channel 6 kV/1 mA VME HV Power Supply Module	48	T5/p.220	
		VME Powered Crate	<i>Powered Crates</i>	VME8001	1U 2 Slot VME64 Mini Crate	163
VME8004B	2U 4 Slot VME64 Mini Crate			163	T9/p.222	
VME8004X	2U 4 Slot VME64X Mini Crate			164	T9/p.222	NEW
VME8008B	4U 8 Slot VME64 Mini Crate			164	T9/p.222	
VME8008X	4U 8 Slot VME64X Mini Crate			165	T9/p.222	NEW
VME8010 - VME8011	7U 21 Slot VME64 Low Cost Crates			162		
VME8100	8U 21 Slot VME64/64X Enhanced Crate series			158	T9/p.222	
VME8200	9U 21Slot VME64X Enhanced Crate series			160	T9/p.222	
Voltage Monitor	<i>Accessories</i>			A1015VM	Analog Voltage Monitor for A1515/A1515TG/A1515QG board	46
Wideband Amplifiers	<i>Preamplifiers</i>	A1423B	Wideband Amplifier	153		

Sales Network

CAEN is proud to have served many customers and research labs world wide.

CAEN continues to supply its equipment to physics research centers and industrial market offering world wide sales and support.

Our products appeal to a wide range of customers including engineers, scientists and technical professionals who all trust them to help achieve their goals faster and more effectively.

CAEN is sure to have the equipment suited to your need, and we will back it up with the best service and support in the industry.

Call today your closest representatives!



Italy and CERN

CAEN SpA

Corporate Headquarters

Via Vetraia 11
55049 - Viareggio • Italy
Phone +39.0584.388.398
Fax +39.0584.388.959
info@caen.it
www.caen.it

USA and Canada

CAEN Technologies, Inc.

1140 Bay Street - Suite 2C
Staten Island, NY 10305 • USA
Phone +1.718.981.0401
Fax +1.718.556.9185
info@caentechnologies.com
www.caentechnologies.com

Germany

CAEN GmbH

Klingenstraße 108
D-42651 Solingen • Germany
Phone +49 (0)212.254.4077
Fax +49 (0)212.25.44079
Mobile +49 (0)151.16.548.484
info@caen-de.com
www.caen-de.com

For a full and updated list of our Resellers and Distributors please visit our website at the following link:

www.caen.it/salesnetwork



This catalog, or parts thereof, may not be reproduced in any form or by any means without written permission from CAEN S.p.A.
CAEN S.p.A has publishing rights for all images reproduced in "2016 / 2017 Product Catalog", except when indicated.

Although every effort has been made to ensure the accuracy of information presented in this catalog, CAEN S.p.A. reserves the right to modify its products specifications without giving any notice; for up to date information please visit www.caen.it.

HV_001_15042016
CRT_001_15042016

Printed in Italy, Mars 2016
Technical Documentation & Communication Office - CAEN S.p.A.
ADOCUME00128
CAT16_17_001_18042016



CAEN S.p.A.

Via Vetraia 11
55049 - Viareggio
Italy
Phone +39.0584.388.398
Fax +39.0584.388.959
info@caen.it
www.caen.it

CAEN GmbH

Klingenstraße 108
D-42651 Solingen - Germany
Phone +49 (0)212.254.4077
Fax +49 (0)212.25.44079
Mobile +49 (0)151.16.548.484
info@caen-de.com
www.caen-de.com

CAEN Technologies, Inc.

1140 Bay Street - Suite 2C
Staten Island, NY 10305
USA
Phone +1.718.981.0401
Fax +1.718.556.9185
info@caentechnologies.com
www.caentechnologies.com