



جامعة الأمير سطام بن عبد العزيز
Prince Sattam Bin Abdulaziz University

COMPUTER HARDWARE MAINTENANCE

LAB MANUAL 2015

Mohammed Yousuf Uddin

College of Computer Engineering and Science

Prince Sattam bin Abdulaziz University

Al Kharj, Kingdom of Saudi Arabia

m.yousuf@psau.edu.sa

Table of Content

Experiments	TITLE	PAGE NO
Chapter 1	Identification of Components of Desktop PC	3
Chapter 2	Motherboard	13
Chapter 3	Power Supply and Voltage Regulatory Module	25
Chapter 4	Assemble and Disassemble the PC	31
Chapter 5	Micro Processor.	38
Chapter 6	Secondary Storage Devices HDD, SDD	47
Chapter 7	Primary Memory	58
Chapter 8	Installing Windows Operating System	68
	Installing Windows Operating System	95

Chapter 1

Introduction to Computer and its Components



Objectives

- Understand the functions of computer
- Identify types of computers
- Identify components of Desktop Computer

Computer

Computer is an electronic and digital device, it take data as input, process it and gives information as output and save it. Computer is used because it is more efficient¹ and effective². Computer hardware is accessed through Software (operating System) computer is Extensible³: means we can add any number of application software to this and extend its functionality. Versatile⁴: means it is used in almost all places like hospitals, business, education, Research etc. Computer is not similar to any other electronic and digital machine but its Versatile and Extensible. Block Diagram of modern Computer.

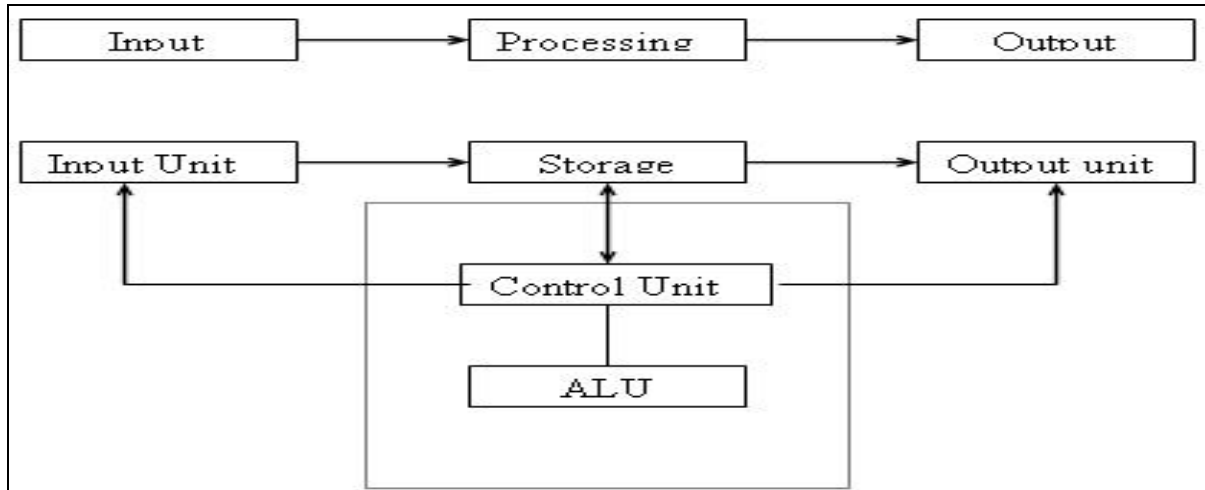

Figure 1.1 Block Diagram of Computer

Computer uses many electronic Components which run on Direct Current such as Integrated circuits, Capacitors, Transistors, Resistors, Buses, Printed Circuit boards.

Computer is Digital it means it process the data stores the data in the form of binary digits (0,1) which are represented in the form of electric voltages 0= -Negative Current 1= + positive voltages.

Input is done through input devices like Keyboard, Mouse, and Scanner etc

Output is done through output devices like Monitor, Printer, and Projector etc

Processing⁵ is done mainly by Processor and also there are many Supporting components for processor to execute the work.

Storage⁶ of data and information is done on Storage devices or Memories like Hard Disk Drive, CD/DVD, and Flash Drives permanently. Other memories used by Processing Unit are RAM, ROM Cache stores the data temporarily during execution or Processing.

Types of Computers

Super Computers: Supercomputers are High performance Computers with multi-tasking high-throughput. Build with thousands of Processor. Supercomputers are used for highly calculation-intensive tasks such as problems including quantum physics, weather forecasting, climate research, oil and gas exploration, molecular modeling and physical simulations such as nuclear fusion.

First Supercomputer was first designed by Seymour Cray in 1960's. As of the 2012 world's fastest super computer is IBM Sequoia with 16.32 PFLOPS followed by Fujitsu K-Computer with capacity of 10.51 PLFOPS. Since June 2013, China's Tianhe-2supercomputer is currently the fastest in the world at 33.86 peta FLOPS (PFLOPS), or 33.86 quadrillions of FLOPS.



Figure 1.2 Tianhe 2 Supercomputer

July 2015 new entry in the Top 10 supercomputers on the latest list is **Shaheen II** at number 7 is a Cray XC40 system installed at **King Abdullah University of Science and Technology (KAUST)** in Saudi Arabia. Shaheen II achieved 5.536 petaflop/sec on the Linpack benchmark, making it the highest-ranked Middle East system in the 22-year history of the list and the first to crack the Top 10 list, with 196608 cores and 7235.2 RPEAK TFLOPS, that is 5.5 petaflop/sec and running on Cray Linux environment.



Figure 1.3 Shaheen 2 Supercomputer

Mainframes: Mainframe computers are powerful computers used primarily by corporate and governmental organizations for critical applications, bulk data processing such as census, industry and consumer statistics, enterprise resource planning, and transaction processing. Mainframes are designed to handle very high volume input and output (I/O) and emphasize throughput computing. Mainframes are measured in millions of instructions per second (MIPS).



Figure 1.4 IBM System Z

Workstations

A workstation is a special computer designed for technical or scientific applications. With higher configuration than a personal computer, main applications include running a multi-user operating systems, 3D graphics and oil and gas exploration and simulation as well other application which requires high computing power. Example in given below image is Dell Precision T7910 with Intel Xeon 2.3 GHz processor with 10 cores, 32 GB RAM and NVIDIA Quadro 4GB graphics card.



Figure 1.5 Dell T7910

Desktop Computers: Desktop Computers are Personal Computers for single users with Speed of 3 to 4 GHz of processing speed.



Figure 1.6 Desktop Computer

Laptop Computers: Laptop is a personal computer and it is portable and all in one layout in which the keyboard, pointing device, are integrated into computer chassis and an LCD display is in a hinged lid. Additionally laptop has a built in battery which supports up to 5 to 6 hours. It is often referred as Notebook.



Figure 1.7 Laptop Computer

Personal Digital Assistant (PDA): is a portable computer small enough to fit in your hand and it is also referred to as palmtop computer. It allows you to perform only a small number of functions.



Figure 1.8 HP PDA

Tablet Computer: is a portable computer larger than PDA with Touch screen for input and with many functionalities different variants are available in the market like Apple iPad, HTC Pad, Samsung, HP, Archos, and Microsoft etc.



Figure 1.9 Apple iPad

Components of a Personal Computer

1. **System Case:** The system case or System Unit, sometimes called the *chassis* or *enclosure*, is the metal and plastic box that houses the main components of the computer.
2. **Monitor** - Your monitor is the component that displays the visual output from your computer as generated by the video card.
3. **Keyboard** - This is the input device to enter the text data in to the computer.
4. **Mouse** - A point and click interface for entering commands which works well in graphical environments.

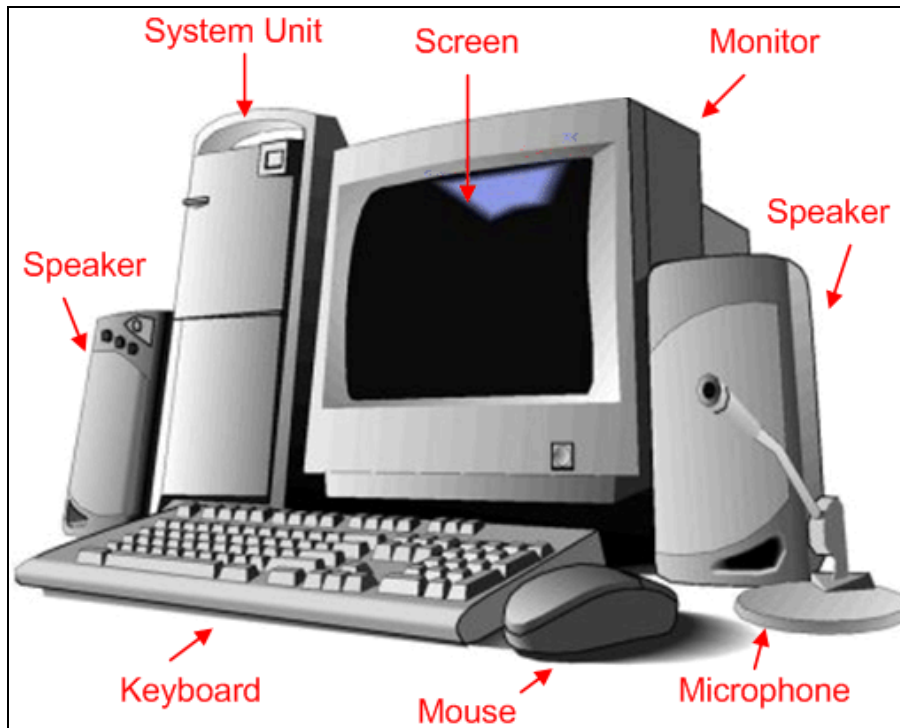

Figure 1.10 Components of Personal Computer

Components inside the System Case

1. **Power Supply** (SMPS) it's a Switch Mode Power Supply, which takes 220 V/ 110 V AC current as input and converts that in to multiple DC voltages.
2. **Hard disk drive(s)** this is where your files are permanently stored on your computer. Also, normally, your operating system is installed here.
3. **CD/DVD drive(s)** this is normally a read only drive where files are permanently stored. There are now read/write CD/DVD drives that use special software to allow users to read from and write to these drives.
4. **Motherboard** **motherboard** is the central printed circuit board (PCB) holds many of the crucial components of the system, while providing connectors for other peripherals. It is also known as Main Board.

Components on a Motherboard

- **Processor Socket:** processor is installed in this socket.
- **Memory Slots:** Primary memory RAM is installed in this slot
- **IDE Connectors:** Hard Disk Drive, CD/DVD Drive, Floppy drive connected here.
- **PCI Slot:** Adapter cards are installed in this slot like Display card, Sound card, Network Interface card, etc
- **PCI-Ex Slot:** it is used to connect Advanced Graphics cards.
- **Power Connectors:** power supply is connected to this.
- **Chipset:** Group of specialized chips on the mother board
- **Back Panel Connectors:** External devices are connected to motherboard or system through this back panel.

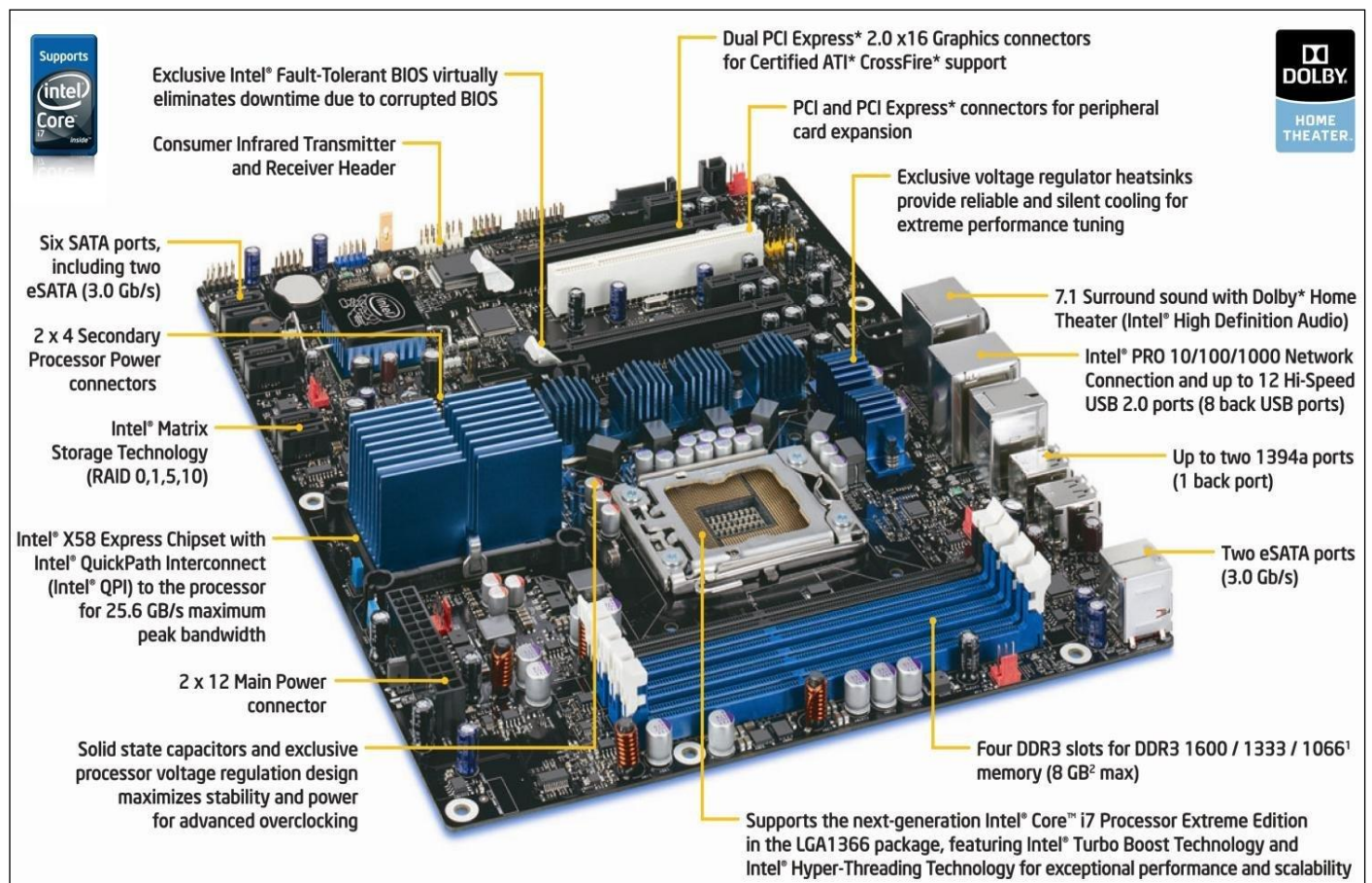

Figure 1.11 Intel DX50 Mother Board

Chipset Memory Control Hub (MCH) also know as North Bridge⁷ Input Output Control Hub (ICH) also know as South Bridge⁸ Buses ROM (Read Only Memory) Other Chips

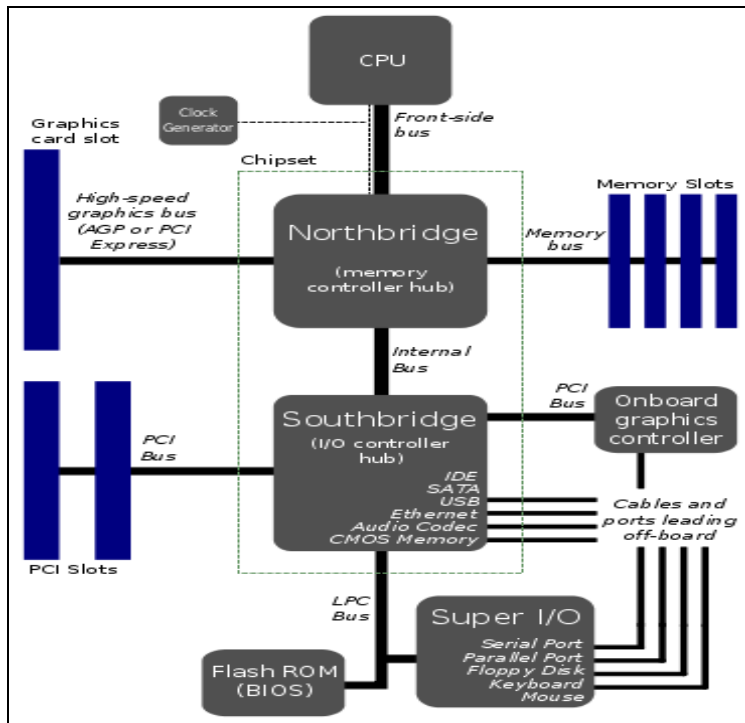
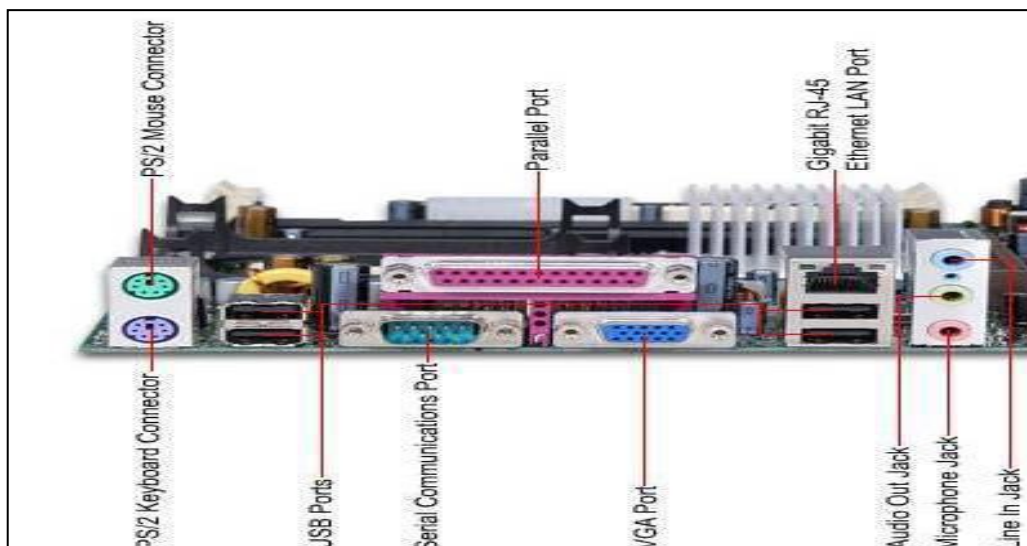

Figure 1.12 Chipset

Back-Panel⁹ Display Connector (VGA) PS/2 Mouse and Keyboard RJ 45 Network Connector Audio Connectors USB Others (HDMI, LPT, COM1, Mini USB, SATA connector etc)



Back Panel

Safety

- ⊗ Check for Static Electricity before you touch system case
- ⊗ Turn-off power supply or unplug power cable before system inspection

Terminologies

1. Efficient فعال
2. Effective
3. Extensible عقد قابل للتجديد
4. Versatile متعدد الإستعمالات
5. Processing
6. Storage تخزين
7. North bridge الجسر الشمالي
8. South bridge الجسر الجنوبي
9. Back-Panel

Chapter 2

Motherboard

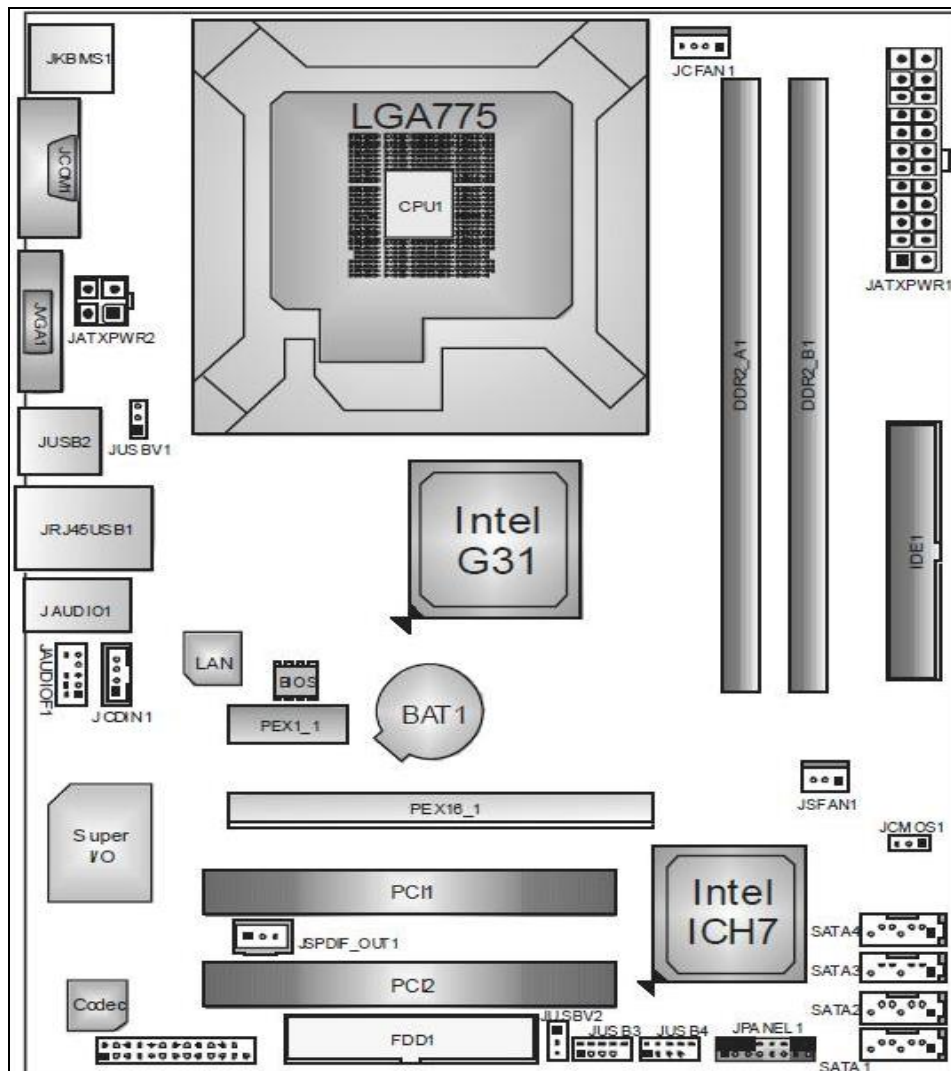

Objectives

- Understand functionality and Architecture of Motherboard
- Identify components on Motherboard
- Practice Connecting components on Motherboard

The PC Case or System Case

The Purpose of PC Case is to hold all the basic components, to protect those components from dust and dirt, to cool the components, and to provide noise reduction.

PC case typically comes with a power supply, cable management systems and mounting locations for the motherboard, drives and other internal components.

Case Form Factors: Form factors¹ refer to physical dimensions (Length, width). PC Case comes in Form Factors to match motherboard form factors such as ATX, BTX.

Case Categories: PC case falls into two categories tower and desktop. A tower² dimension is oriented vertically, desktop dimension is oriented horizontal. They come in various sizes and quality. Such as Full Tower, Mid Tower, Mini Tower, Desktop, and Low Profile.

Full Tower is 3 to 4 feet tall

Mid Tower is slightly smaller than Full tower cases

Mini tower is 14 to 15 inches tall

Desktop is classical horizontally oriented desktop case 14 inches wide and 5 inches tall.

Low Profile case is scaled down version of the desktop case, also called “slimline”



Figure 2.1 PC Case Tower



PC Case Desktop or Low Profile

Motherboard

Motherboard³ is the Printed circuit board and it is the main component of the system, every component internal or external connects directly or indirectly to motherboard. It is also known as *mainboard* or printed circuit board, system board. It is made of fiberglass brown or green typically with a meshwork of copper lines these lines are electronic circuits through which power, data, and control signals travel. Group of these lines assigned a set of functions, is collectively called a “bus”.

There are ways in which components are connected⁴ to the motherboard.

1. Integrated in to the circuit board of the motherboard (in build video, audio, NIC controllers)
2. Attached through connectors, sockets, slots on board (processor, RAM, HDD, CD/DVD)
- 3 Attached through external back panel or front panel (Keyboard, Mouse, Speakers, USB drive)

Form Factors of Motherboard

The form factor refers to the physical dimensions (size and shape) as well as certain connector, screw hole, and other positions that dictate into which type of case the board will fit.

BTX	New-generation tower and desktop systems; likely to be the most common form factor from 2007 and beyond; supports high-end systems
microBTX	Smaller version of BTX; used in new-generation mid-range systems; fits the microBTX or BTX chassis
picoBTX	Smallest version of BTX; used in low-end small form factor, entertainment, or appliance systems; fits the picoBTX, microBTX, or BTX chassis
ATX	Standard tower and desktop systems; most common form factor from mid-1996 through the present; supports high-end systems
Mini-ATX	A slightly smaller version of ATX that fits the ATX chassis; many ATX motherboards are sold as Mini-ATX motherboards
microATX	Smaller version of ATX; used in mid-range systems; fits the microATX or ATX chassis
Mini-ITX	Minimum-size FlexATX version; used in set-top boxes and compact/small form factor systems; highly integrated with one PCI expansion slot; fits in the Mini-ITX, FlexATX, microATX, or ATX chassis
NLX	Corporate slim desktop or mini-tower systems; fast and easy serviceability; slots on riser card; largely replaced in recent systems by microATX, FlexATX, and Mini-ITX designs

Main Components of Motherboard

- Processor Socket
- Memory Slots
- Chipset
- Bus Architecture
- Firmware
- BIOS
- CMOS
- Motherboard Connectors
- Adapter cards Slots

Processor Socket

Processor is mounted on the motherboard in a socket.

Types of Socket

- Pin Grid Array (PGA)
- Land Grid Array (LGA) (socket T)
- Ball Grid Array (BGA)
- Flip Chip PGA

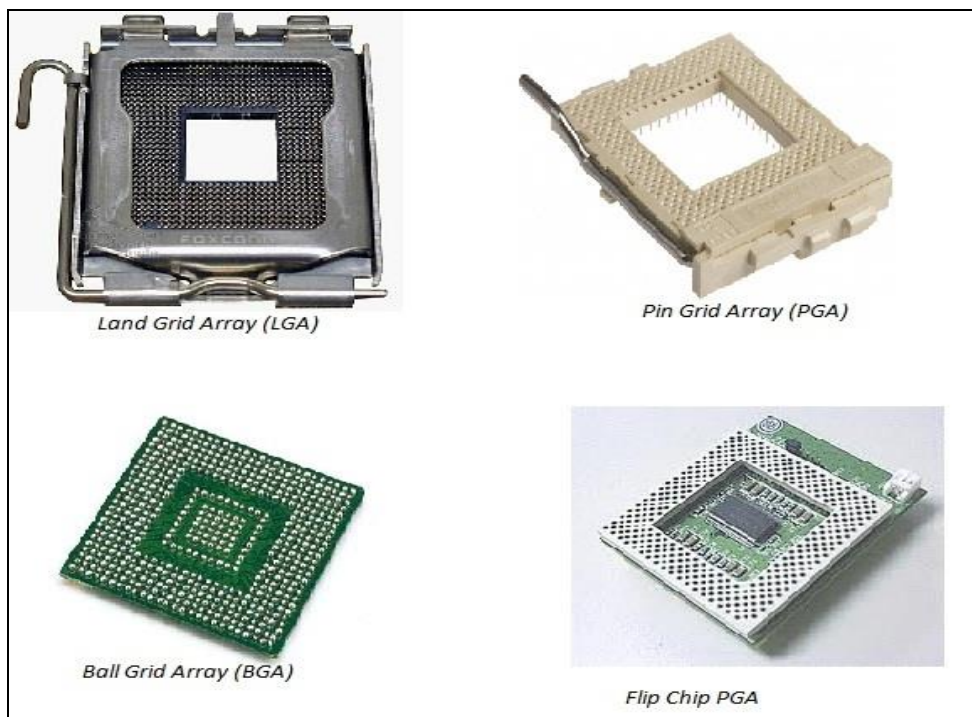

Figure 2.2 Processor Sockets

Primary Memory Slots

- 172-pin MicroDIMM, used for DDR SDRAM
- 184-pin DIMM, used for DDR SDRAM
- 200-pin SO-DIMM, used for DDR SDRAM and DDR2 SDRAM
- 204-pin SO-DIMM, used for DDR3 SDRAM
- 214-pin MicroDIMM, used for DDR2 SDRAM
- 240-pin DIMM, used for DDR2 SDRAM, DDR3 SDRAM and FB-DIMM DRAM



Figure 2.3 Memory Slot

Chipset

Chipset refers to a group of integrated circuits, or chips, that are designed to work together. A chipset controls the system bus structures and facilitates the movement of data and instructions between the Processor, cache memory and internal and external peripheral devices.

Two main chips in chipset are Memory Control Hub (Northbridge) and Input Output Control Hub (Southbridge). The Northbridge links the CPU to very high-speed devices, especially main memory and graphics controllers, and the Southbridge connects to lower-

speed peripheral buses (such as PCI). In many modern chipsets, the Southbridge actually contains some on-chip integrated peripherals, such as Ethernet, USB, and audio devices. Chipset controls the flow of bits that travel between the CPU, system memory, and the motherboard bus. Efficient data transfers, fast expansion bus support, and advanced power management and many more are the features of chipset.

A chipset is usually designed to work with a specific family of microprocessors. Because it controls communications between the processor and external devices, the chipset plays a crucial role in determining system performance.

Every chipset has a specific model number and its two main chips North Bridge and South Bridge model numbers. We can identify them in following ways

1. Using Chipset Identification Utility: download a tool from Intel or third party website and install the tool to identify the chipset model.
2. Through Device manager: click **Start** » click **Control Panel** » double-click the **System** icon » click the **Hardware** tab » click **Device Manager** Click the sign to expand the **System devices** entry. Look for the chipset name in a string similar to the following: "Intel® 955X Memory Controller Hub - 2774". In this example, the chipset is an Intel® 955X Express Chipset.

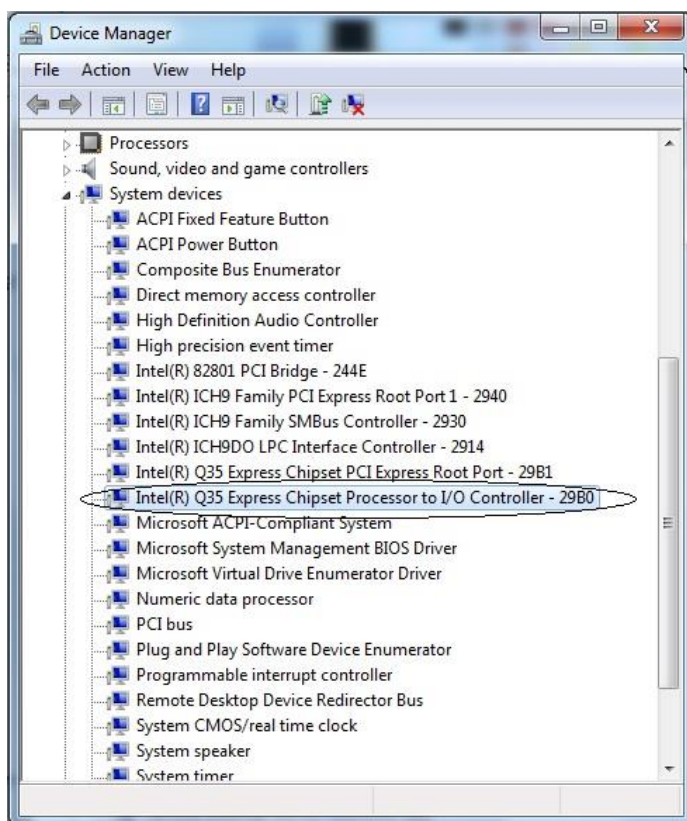

3. Product Documentation
4. Chipset Marking: Open the System case and on the motherboard find the chipset marking or chipset model number.

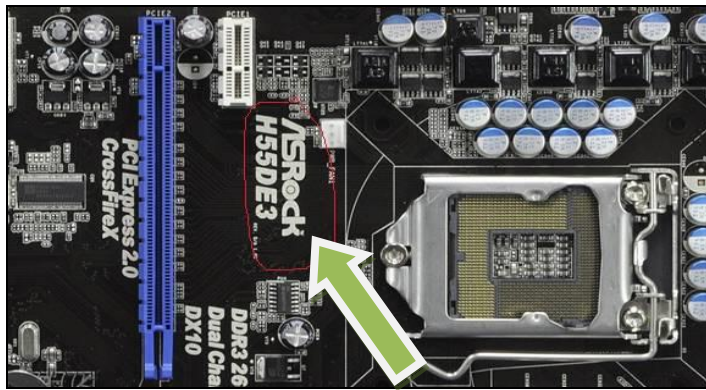

Figure 2.4 Chipset Model

Given below is the list of few chipset models and processor compatible with them.

Chipset	Part numbers	South Bridge	Processors	FSB	Memory type
945GC	82945GC (MCH)	ICH7/ICH7R/ICH7-DH	Pentium 4, Pentium D, Celeron D, Core 2 Duo, Pentium Dual-Core, Atom	533/800 MHz	DDR2 533/667
P965	82P965 (MCH)	ICH8/ICH8R/ICH8-DH	Pentium Dual-Core/Core 2 Quad/Core 2 Duo	533/800/1066 MHz	DDR2 533/667/800
Q35	82Q35 (MCH)	ICH9/ICH9R/ICH9-DO	Pentium Dual-Core/Core 2 Quad/Core 2 Duo	800/1066/1333 MHz	DDR2 667/800
H55	BD82H55 (PCH)	SLGZX(B3)	Core i3/i5/i7 Mobile	2 GB/s	DMI
QS77	BD82QS77 (PCH)	SLJ8B(C1)	Core i3/i5/i7 Mobile	4 GB/s	DMI

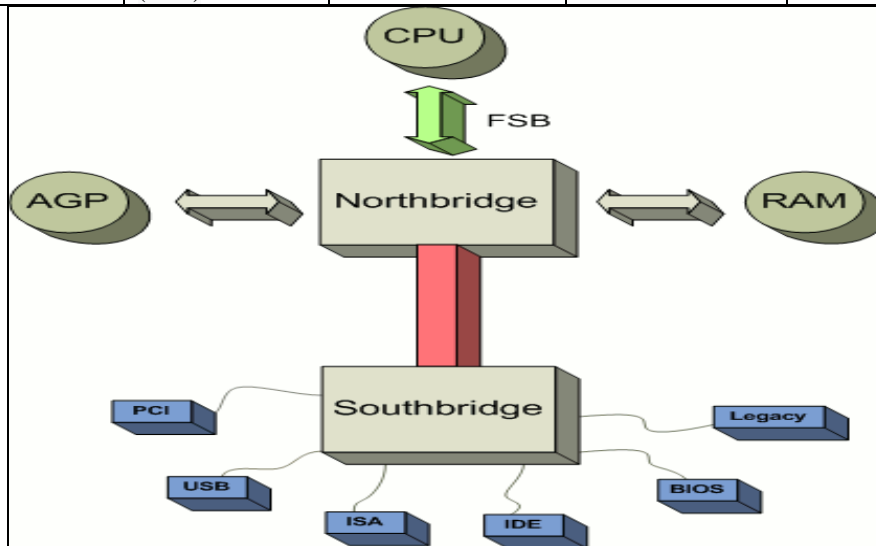

Figure 2.5 Chipset Block Diagram

Bus Architecture

It refers to pathways that power, data, and control signals use to travel from one component to another in the computer. There are different types of buses.

Processor Bus: data and control signals to and from processor travel through this bus it is also known as Front Side Bus

Memory Bus: data and control signals to and from primary memory (RAM) travel through this bus.

Input Output Bus: data and control signals to and from input and output devices travel through this bus.

The **system crystal** determines the speed at which a CPU and the rest of the PC operate. This is called the **system bus speed**. The system crystal is usually a quartz oscillator, very similar to the one in a wristwatch, soldered to the motherboard (Figure 2.6). The quartz oscillator sends out an electric pulse at a certain speed, many millions of times per second. This signal goes first to a clock chip that adjusts the pulse, usually increasing the pulse sent by the crystal by some large multiple. As long as the PC is turned on, the quartz oscillator, through the clock chip, fires a Charge on the CLK wire, in essence pushing the system along. Before you install a CPU into a system, you must make sure that the crystal and clock chip send out the correct clock pulse for that particular CPU.

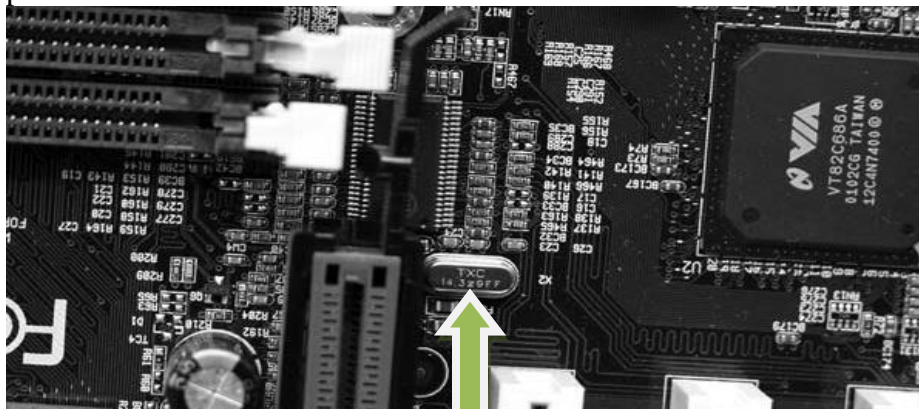

Figure 2.6 Quartz Oscillator

Firmware

Firmware⁵ refers to software instructions, usually stored on ROM chips. Firmware exists on most PC components, such as video adapter, hard drives, network adapter and printers. These instructions are always available, so they are not reprogrammed every time the computer is started.

BIOS: Basic Input Output System

BIOS is a term that stands for basic input output system, which consists of low-level software that controls the system hardware and acts as an interface between the operating system and the hardware. It is responsible for informing the processor of the devices present and how to communicate with them. Whenever the processor makes a request of a component, the BIOS steps in and translates the request into instructions that the component can understand.

Older Computers contained a true Read-Only BIOS that cannot be altered. Now the flash BIOS can be electronically upgrade so that it can recognize new device type. Given below is the illustration of system as layers⁶ where BIOS is in between hardware and Operating System.

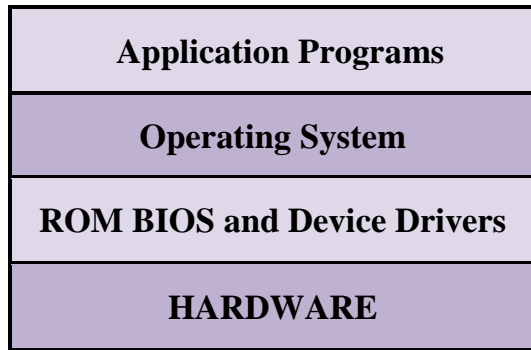

Figure 2.7 PC System Layers

CMOS: Complementary Metal Oxide Semiconductor is another type of firmware, which stores settings such as data and time, keyboard settings, boot sequence. Interrupt Request line and I/O resources that BIOS uses. It is also referred as RTC/NVRAM (Real Time Clock Non Volatile RAM), this chip is volatile⁷ but it is supplied with power from Lithium Battery as show in the given below figure 2.8.

You can enter and edit the settings by entering the computer's Setup Program during boot up process. This is also referred as BIOS Setup.

Note: BIOS and CMOS not to be confused they are two separate components.

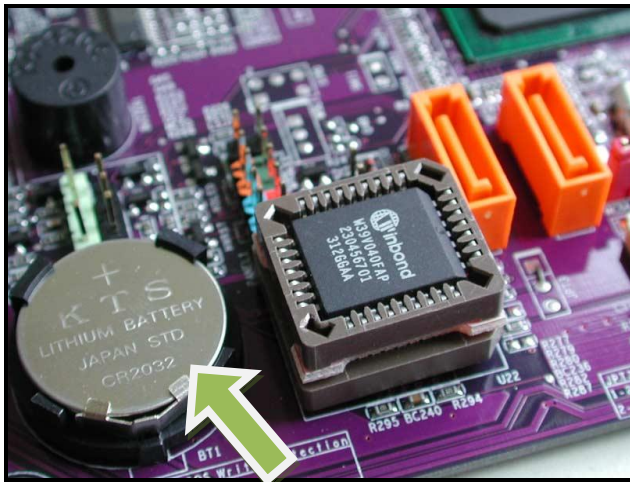

Figure 2.8 CMOS Battery

UEFI: (Unified Extensible Firmware Interface) is a standard firmware interface for PCs, designed to replace BIOS (basic input/output system). This standard was created by over 140 technology companies as part of the UEFI consortium, including Microsoft. It's designed to improve software interoperability and address limitations of BIOS. Some advantages of UEFI firmware include:

- Better security by helping to protect the pre-startup—or pre-boot—process against bootkit attacks.
- Faster startup times and resuming from hibernation.
- Support for drives larger than 2.2 terabytes (TB).
- Support for modern, 64-bit firmware device drivers that the system can use to address more than 17.2 billion gigabytes (GB) of memory during startup.
- Capability to use BIOS with UEFI hardware.

Mother Board Connectors

All of the components of a computer directly⁸ or indirectly⁹ connect to motherboard and some are in-built¹⁰. In many ways connection is established they are as follows.

- On Board Connection: here component is fixed on to board using **Slots** and **Sockets** on mother board. Example Processor, RAM, Network card, AGP card etc
- Internal Connection: Components inside the System case connects to mother board using **connectors**. Example Hard Disk Drive, CD/DVD Drive, etc
- External Connection: Components external to the system case are connected through **back-panel**.

SLOTS: slot is a narrow opening through which an object can pass. Here on motherboard a slot is used to fix an adapter card in to it. There are different types of slot available but most common which are seen on most of the motherboards are given below.

PCI Slots (*Peripheral Component Interconnect*): *PCI is bus to connect the expansion cards like network card, modem card, video card etc, PCI Slot is the most common slot found on almost all of the mother boards. . There are many variants of PCI bus as follows.*

	133 MB/s (32-bit at 33 MHz)
	266 MB/s (32-bit at 66 MHz or 64-bit at 33 MHz)
	533 MB/s (64-bit at 66 MHz)

Figure 2.9 PCI Slot

PCI Express (PCIe): this slot is as PCI but with numerous improvements such as maximum system bus throughput, high speed, and low pin count.

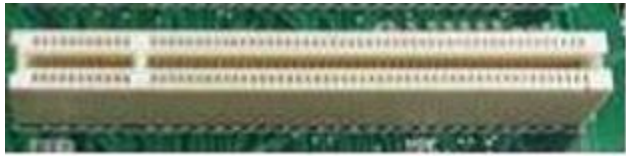

x1	BANDWIDTH Single direction: 2.5 Gbps/200 MBps Dual Directions: 5 Gbps/400 MBps	
x4	BANDWIDTH Single direction: 10 Gbps/800 MBps Dual Directions: 20 Gbps/1.6 GBps	
x8	BANDWIDTH Single direction: 20 Gbps/1.6 GBps Dual Directions: 40 Gbps/3.2 GBps	
x16	BANDWIDTH Single direction: 40 Gbps/3.2 GBps Dual Directions: 80 Gbps/6.4 GBps	

Figure 2.10 PCI E Slots

PCI Express Version	Transfer Rate	Bandwidth in x16
1.0	2.5 GT/s	32 Gbit/s or 4 GB/s
2.0	5 GT/s	64 Gbit/s or 8 GB/s
3.0	8 GT/s	126 Gbit/s or 15.7 GB/s
4.0	16 GT/s	252 Gbit/s or 31.5 GB/s

The PCI Express bus is hot plug, i.e., it's possible to install and remove PCI Express boards even when the PC is on. PCI Express slot is connected to the motherboard chipset using a dedicated lane, not sharing this lane (data path) with other PCI Express slots.

The PCI Express x16 slot was developed to be used by video cards. PCI Express has replaced AGP as the default interface for graphics cards on new systems. With a few exceptions, all graphics cards being released as of 2009 from ATI and NVIDIA use PCI Express. NVIDIA uses the high bandwidth data transfer of PCIe for its Scalable Link Interface (SLI) technology, which allows multiple graphics cards of the same chipset and model number to be run in tandem, allowing increased performance.

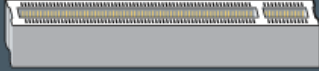
Power Connectors: Power Supply (SMPS) supplies power to mother board. Different Form factors of power supply are available for desktop computers, such as ATX, BTX, LPX, microATX , Flex ITX.

ATX (Advanced Technology Extension) is widely used. The ATX specification requires the power supply to produce three main outputs, +3.3 V, +5 V and +12 V.





The power supply connectors	
	4 Pin Molex Connector This is used to power various components, including hard drives and CD/DVD drives. <i>available in: AT, ATX & ATX-2</i>
	20 Pin Molex ATX Power Connector This is used to power the motherboard in ATX systems. <i>available in: ATX(ATX-2 have four extra pins)</i>
	4 Pin Molex P4 12V Power Connector Used specifically for Pentium 4 Processor Motherboards.
	6 Pin AUX Connector Provides +5V DC, and two connections of +3.3V. <i>available in: ATX/ATX-2</i>
	15 pin SATA Connector Provides + 3.3 DC available in ATX-2 Used for Hard disk and CD/DVD drive

Figure 2.11 Power Connectors.

Parallel ATA Connector (PATA): It is 40 Pin connector. A ribbon cable¹¹ connects the Hard disk drive and CD/DVD Drive to the interface, as shown in the figure below.

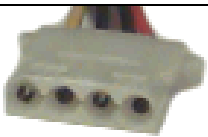
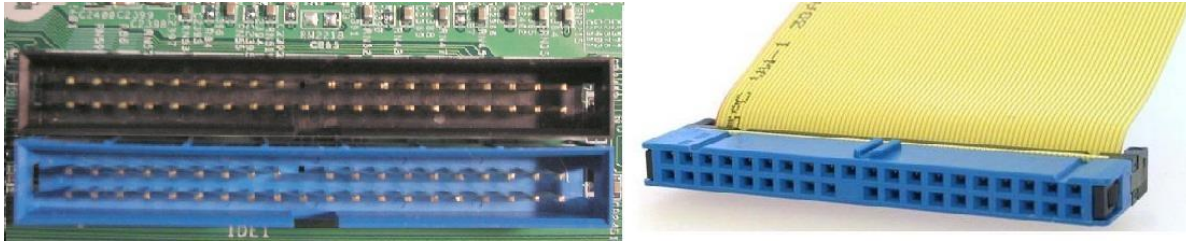

Figure 2.12 PATA Connectors.

Serial ATA (SATA): SATA is the High Speed Interface with seven conductors, SATA ribbon cable can be of 1 meter, it enables Hot-plugging. Figure below show cable and connector on motherboard.



Figure 2.13 SATA Connector

Back Panel Connectors

ATX boards have a unique double-high connector area for all the built-in connectors on the motherboard. When the computer is mounted, those motherboard parts show up at the computer case back panel. They are used to plug the mouse, keyboard, monitor, printer, sound and any other peripherals you may have.

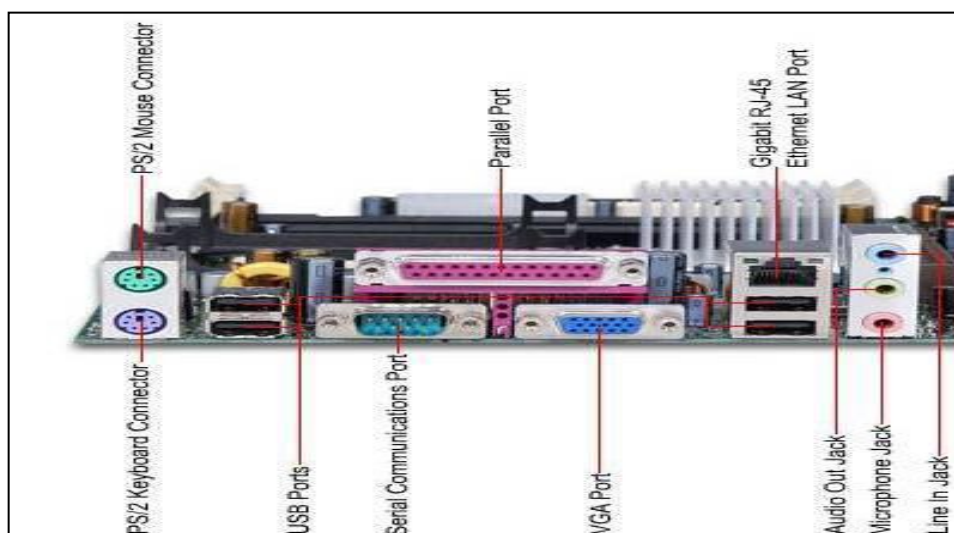

Figure 2.14 Back panel connectors

Safety

- ⊛ Use anti-static electric discharge pad or wear shoes before touching motherboard
- ⊛ Do not touch pins inside Processor Socket

Terminologies

10. Form-Factors
11. Tower برج
12. Motherboard اللوحات الرئيسية
13. Connected متصل
14. Firmware البرامج الثابتة
15. Layers طبقات
16. Volatile متطاير
17. Directly مباشره
18. Indirectly على نحو غير مباشر
19. In-built يحمل في ثناياه عوامل
20. Ribbon-Cable الشريط الكابل

Chapter 3

Power Supply and Voltage Regulatory Module



Objectives

- Understand the Power Supply Units, Specifications and Cable Connections
- Identity and Trouble Shoot Power Supply problems
- Understand Voltage Regulatory Module on motherboard
- Test and Trouble shoot Voltage Regulatory Module on motherboard

SMPS

Figure 3.1 SMPS

Power supply unit (PSU) or Switch Mode Power Supply (SMPS) converts 110V or 220V AC current into the DC voltages which a computer needs to operate. These are +3.3VDC, +5VDC, –5VDC (on older systems), +12VDC, and –12VDC. The jacket on the leads carrying each type of voltage has a different industry standard color coding for faster recognition. A watt is a unit of power. The higher the number, the more power your computer can draw from the power supply. Think of this rating as the “capacity” of the device to supply power. Most computers require power supplies in the 250- to 500-watt range. Higher wattage power supplies might be required for more advanced systems that employ power-hungry graphics technologies or multiple disk drives, for instance. PSU that powers a PC and utilizes switching power conversion (SPC) is known as Switch mode power supply. The principle of SPC takes energy from the power grid, and then it's chopped with a high-frequency rate into smaller energy packets with the use of some fast switches (FETs), and finally, it's transferred with the help of components like capacitors and inductors. In the end, all of the energy packets are merged, and after some rectification processes, energy flows smoothly from the output.

Inside the power supply unit there are electronic components that are inductor coils, transformers, capacitors, resistors, transistors and diodes. Quality of these components plays the main role in reliable functioning of power supply units.



Figure 3.1 inside SMPS

SMPS Cooling

A very important component of most PSUs is the fan that handles cooling. However, there are some passive PSUs that don't utilize any active cooling. Fans keep sensitive components (like electrolytic caps) at appropriate temperatures. Doing this prolongs the PSU's life span, but the type

and quality of the fan also plays a key role in its noise output. The circuit that controls the fan is responsible for its speed, and thus acoustic profile, under various conditions. If a manufacturer uses a high-speed fan, chances are that it will increase the overall noise output, especially at higher loads. PSU's are of different types, sleeve bearing fans, double ball bearing fans, fluid dynamic bearing and Hydro dynamic bearing fans.

SMPS output cables and Connectors

AC Input / DC Output						
AC INPUT	200~240v ~ 5A 50-60 Hz					
DC OUTPUT	+3.3v	+5v	+12v	+12v	-12v	+5vsb
	22A	19A	24A	21A	0.3A	2.5A
TOTAL POWER	130W		480W		3.6W	12.5W
	500W					

The figure shows six different power supply connectors arranged in two rows of three. Each connector is shown with its corresponding label below it:

- CPU 4+4 Pin x1**: A yellow 4+4 pin connector.
- Motherboard 20+4 Pin x1**: A multi-colored 20+4 pin connector.
- SATA x6**: A black SATA power connector.
- Floppy 4 Pin x1**: A black 4 pin connector.
- PCIe 6+2 Pin x1**: A multi-colored 6+2 pin connector.
- Peripheral 4 Pin x3**: A black 4 pin connector.

Figure 3.2 Connectors

Power supply units' gives different output lanes with different type of connector, purpose of this variation in type of connector is to provide safety and convenience to connect different devices in system case with power supply unit. Cable are color coded, different color indicates different voltages, figure given below show the color codes.

Color	Signal	Pin	Pin	Signal	Color
Orange	+3.3 V	1	13	+3.3 V	Orange
				+3.3 V sense	Brown
Orange	+3.3 V	2	14	-12 V	Blue
Black	Ground	3	15	Ground	Black
Red	+5 V	4	16	Power on	Green
Black	Ground	5	17	Ground	Black
Red	+5 V	6	18	Ground	Black
Black	Ground	7	19	Ground	Black
Grey	Power good	8	20	Reserved	N/C
Purple	+5 V standby	9	21	+5 V	Red
Yellow	+12 V	10	22	+5 V	Red
Yellow	+12 V	11	23	+5 V	Red
Orange	+3.3 V	12	24	Ground	Black

Figure 3.3 ATX-24 pin connector color code

Power supply should be tested first in case of no power on, as follow

1. Test wall socket for desired AC output
2. Test power cable
3. Check SMPS Fan
4. Test output voltages from SMPS based on voltage given in figure 3.3

To power on SMPS outside the System case, short circuit the Power On (green) cable with ground (black) as shown in the figure below. Multi meter is tool to test the different voltage outputs from the power supply.

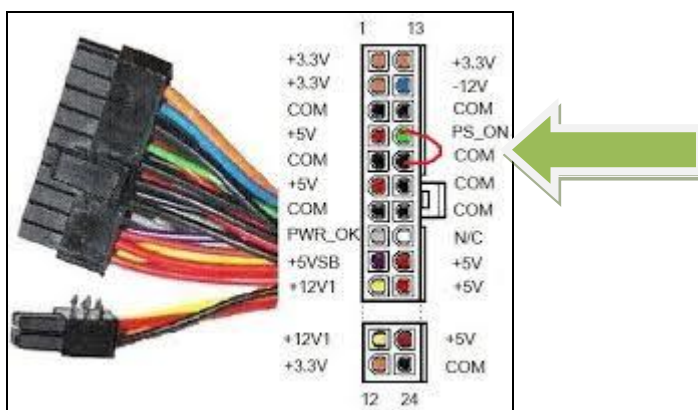

Figure 3.4 Power-on SMPS

Voltage Regulatory Circuit

Voltage regulatory circuit supplies power to processor, it also know as processor power module, A good voltage regulator won't have any fluctuations or noise on its outputs, providing the CPU and other components with a clean and stable voltage, allowing them to work perfectly. A bad voltage regulator can lead to fluctuations or noise on the voltage that will lead to malfunctions like the computer crashing, resetting and presenting the infamous Blue Screen of Death on Windows.

VRM is divided as phases or channels on motherboard, more the phases better the quality of motherboard in general there are 3 phases on motherboard, high performance and high quality motherboards offer up to 12 phases of VRM on it.

Each phase consist of following electronic components

1. Induction coil or Choke (each phase 1 coil)

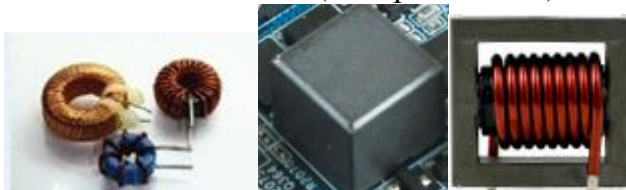

2. MOSFETs (Metal-Oxide Semiconductor Field Effect Transistor) (each phase 3)

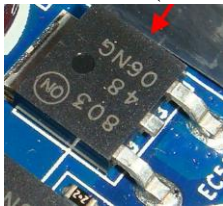

3. Capacitors (each phase 3 capacitors)

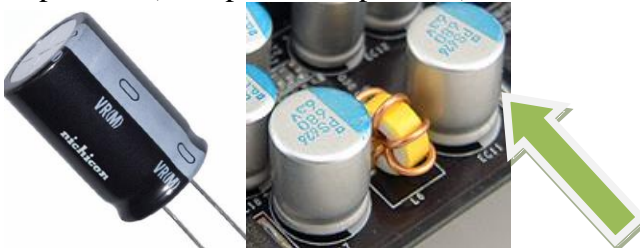

4. MOSFET Driver IC (1 per Phase)

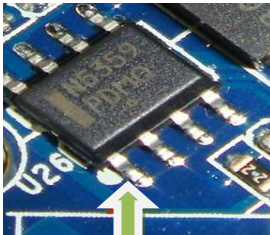

Each Phase thus consist of one coil, 3 MOSFET, 3 Capacitor, 1 MOSFET driver.

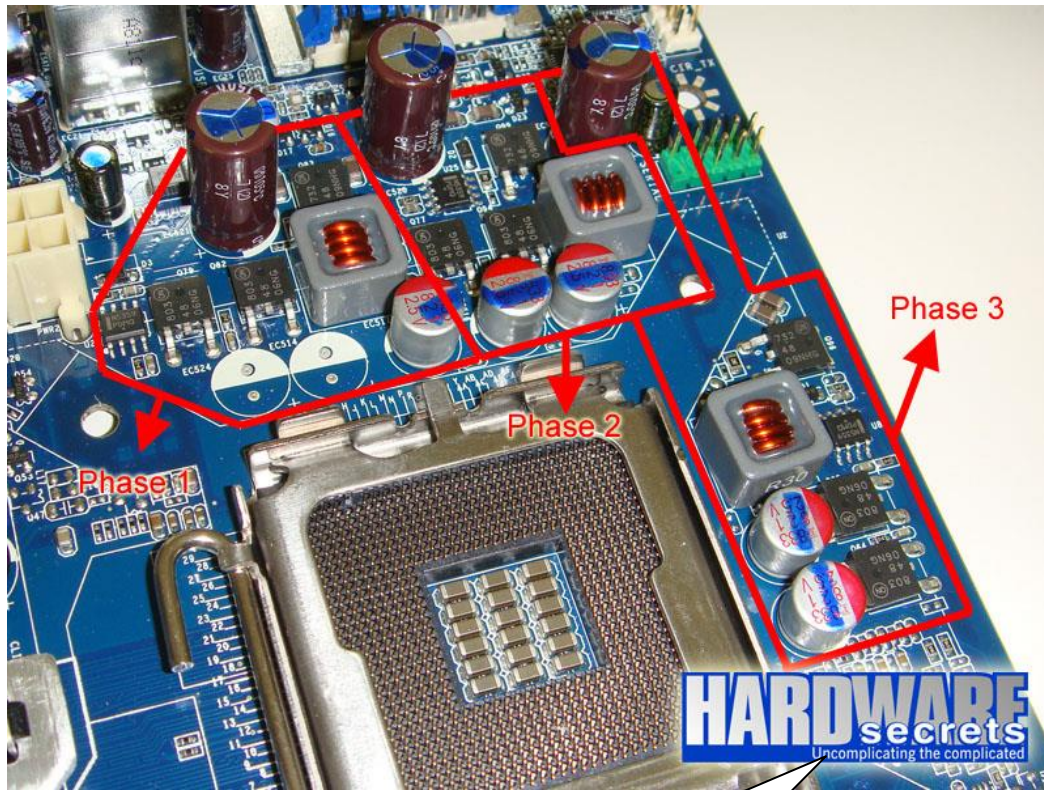

www.hardwaresecrets.com



**ASROCK X99M Motherboard
with 12 Phases**

Chapter 4

Assemble and Disassemble the Desktop PC

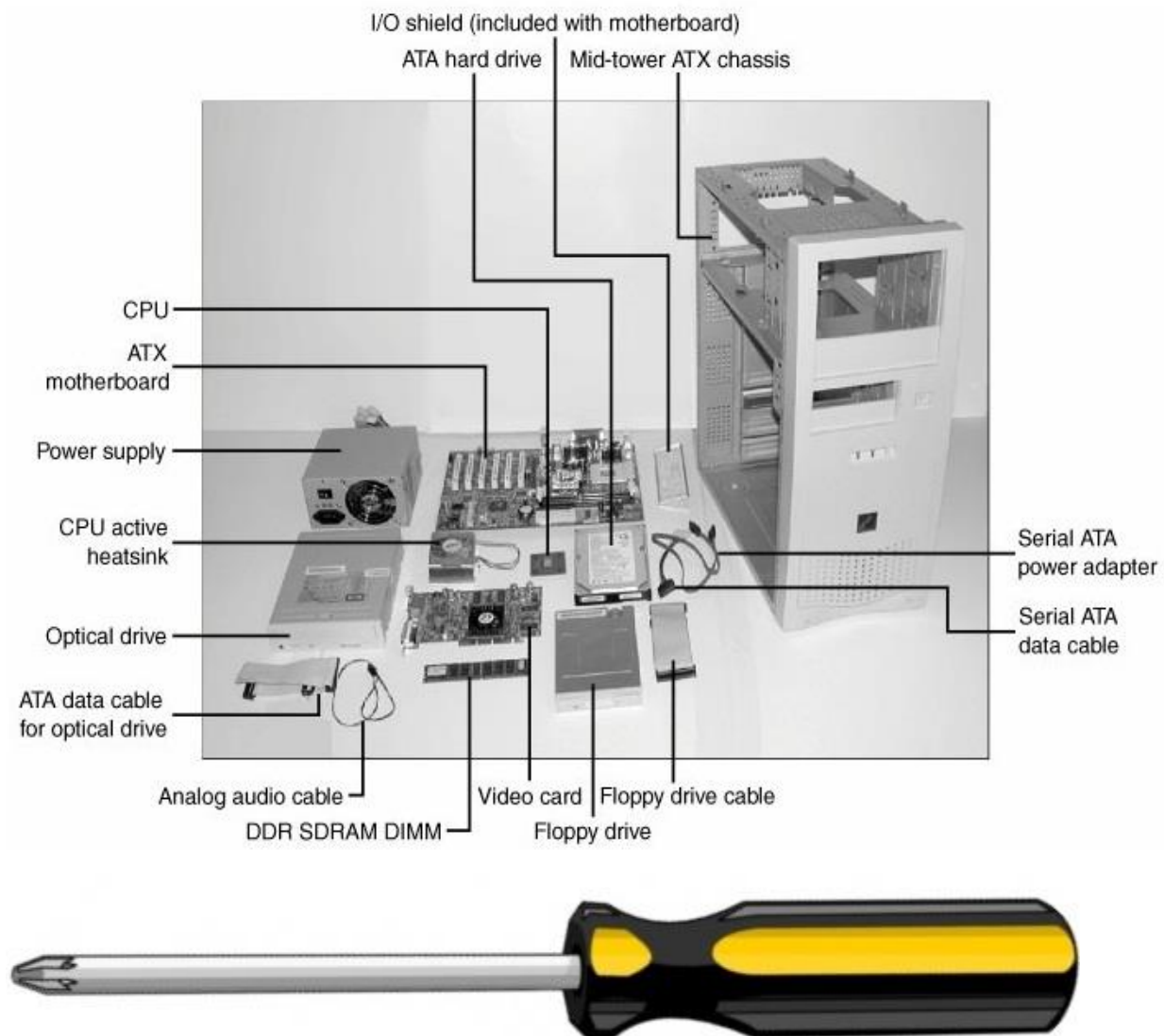

Objectives

- Assemble and Disassemble the whole Desktop computer
- Identity and use tools
- Troubleshoot connection problems

The components used in building a typical PC are as follows:

- Case and power supply
- Motherboard
- Processor with heat-sink¹ and fan²
- Memory
- Floppy drive (optional)
- Hard disk drive
- Optical drive(s) (CD and/or DVD)
- Keyboard and pointing device (mouse)
- Video card and display
- Sound card (optional) and speakers
- Modem (optional) or network interface card (optional)
- Cables
- Hardware (nuts, bolts, screws, and brackets)
- Operating system software

Tools used to assemble and disassemble

- Flat or straight screw driver
- Phillips/square or Quadrex screw
- Trox screw driver etc



Figure 4.0 Quadrex bits



Figure 4.1 Tweezers



Figure 3.2 Cable Cutter



Figure 4.3 Claw Tool

The following sections cover the assembly and disassembly procedure:

1. System Case and Power Supply
2. Motherboard, Processor, Heat sink, RAM.
3. Adapter cards
4. Disk Drives
5. External Devices

System Case and Power supply (SMPS)

System Case and Power Supply are available as single unit pre-attached, if not, assemble the power supply as follows.

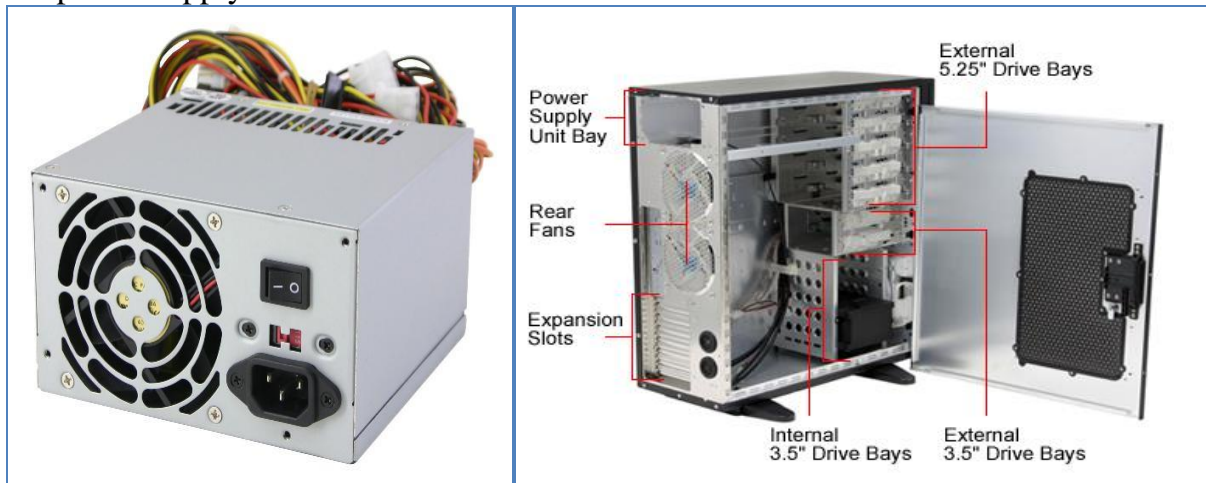

Figure 4.3 SMPS

Figure 4.4 System Case

Note: SMPS should be set to proper Input Voltage Level 220 or 110.

Motherboard

Motherboard should be prepared as follows

Processor: While inserting Processor, in to processor socket. One should follow the marking on the processor and processor socket they should be on same side.

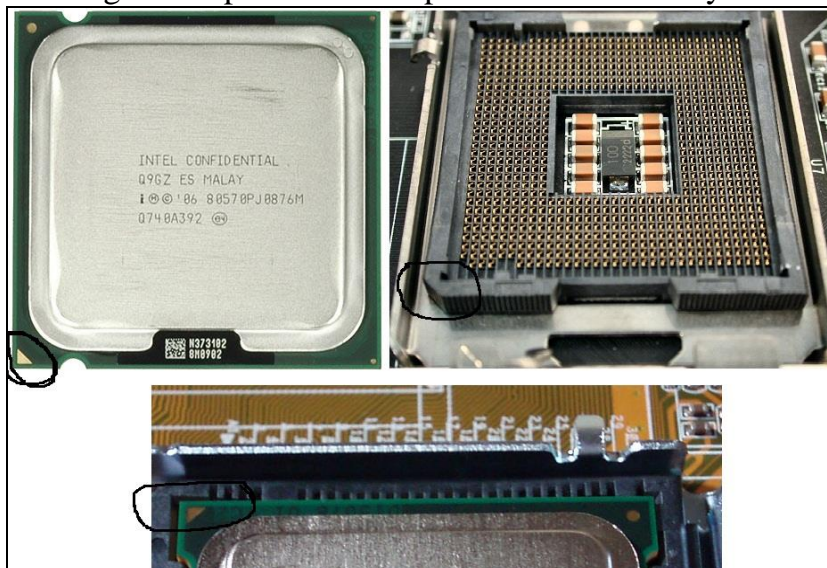

Figure 4.5 Processor and Processor Socket direction for assembling

Heat sink and Processor Fan: heat sink is the metal piece made of Aluminum Alloy which acts as heat exchanger, it disperses the heat in to surrounding air, and heat-sink is used to cool the high power semiconductor devices. On computer motherboard it used on processor, memory control hub and Input Output Control hub. Before placing heating on any chip heat sink compound is used it is a viscous fluid it is also known as thermal grease⁴ it increases thermal conductivity.



Figure 4.6 Heat sink



Figure 4.7 Thermal grease

Heat sink Fan: a fan is attached on the top of processor heat sink and other heat sink is left without fan or it is not required. This fan will exhort the hot air from heat sink.

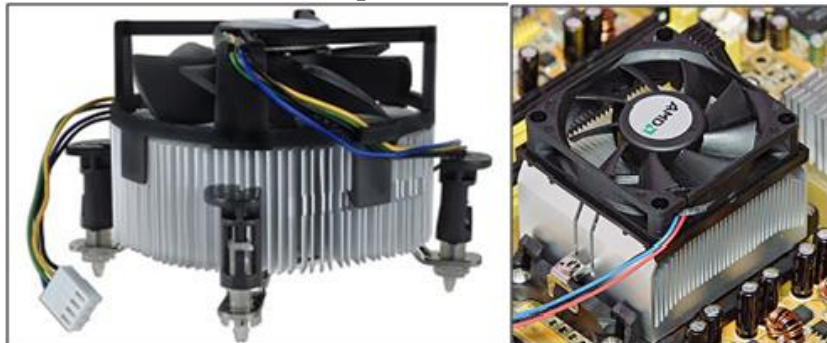

Figure 4.8 Heat sink with fan

Insert RAM in to DIMM Slots

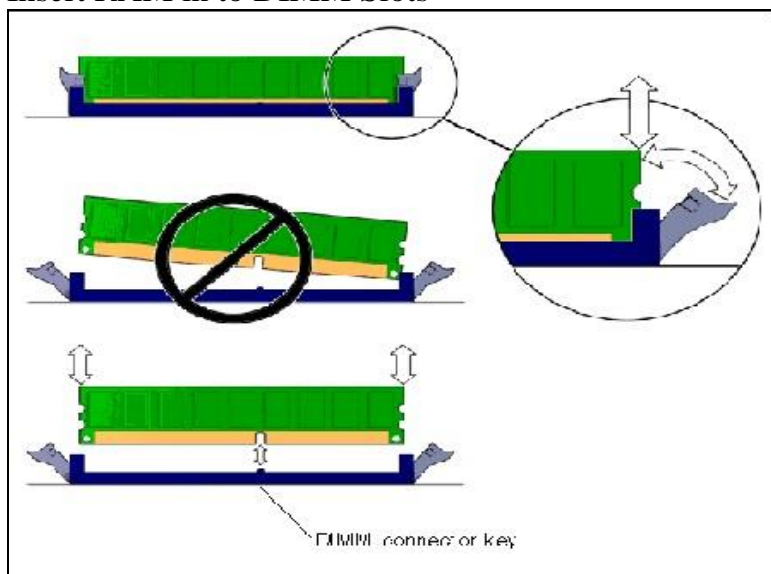

Figure 4.9 RAM Placement

Disk Drives: Disk drives (Hard Disk Drives, CD/DVD Drives) should be mounted in to racks of the system case and alignment should be proper.

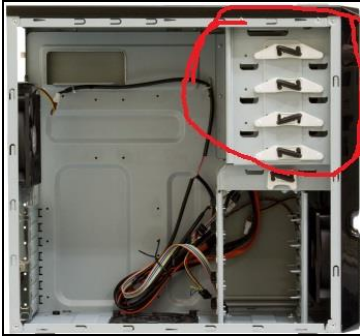

Figure 4.10 Disk Racks in system case

Motherboard should be placed in to the system case here two things should be taken in to account.

1. Position of the screw holes and standoffs
2. Back panel alignment

After motherboard is placed in to system case and screws and standoffs are fixed carefully next step is to connect all the cables.

Connect Power cable to motherboard

Hard Disk Drive CD/DVD power cable and Data cable (SATA/PATA)

Connect Front panel cables for Power Switch, Restart, USB, LEDs, and Audio Jacks. Refer motherboard manual for connections or follow the labels of connectors and motherboard or in few motherboards pin pattern act as guide.

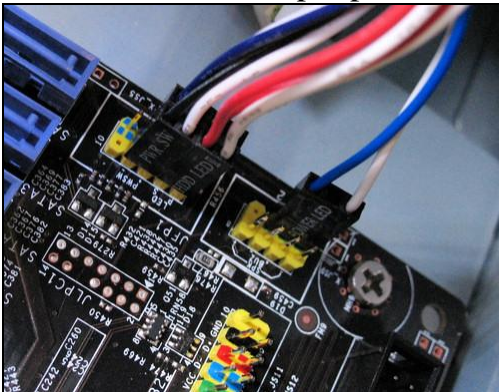

Figure 4.11 Front Panel Connectors

Adapter cards: like Network interface cards, Display cards, Modem cards. Etc is installed in to system on Slots like PCI AGP PCIe and others. To install an adapter card first identify the card and slot required for it. If available place the card in to slot carefully insert with little force and ensure complete connect.

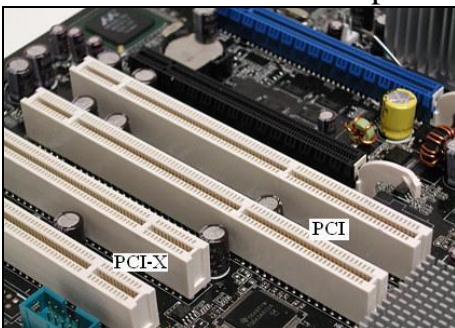

Figure 4.12 Expansion Slots

External Devices: External Device like Monitor Keyboard, mouse, Speakers, Printers etc are connected through back panel and USB devices and audio devices can be connected through front panel⁵ also

Monitor requires power and data through separate connections. Power is given directly or even through SMPS, Data cable is connected to the back –panel of the system (motherboard). There are different types of connectors, but VGA is the standard connector. Other than VGA there are HDMI and DVI as shown in the figure given below.

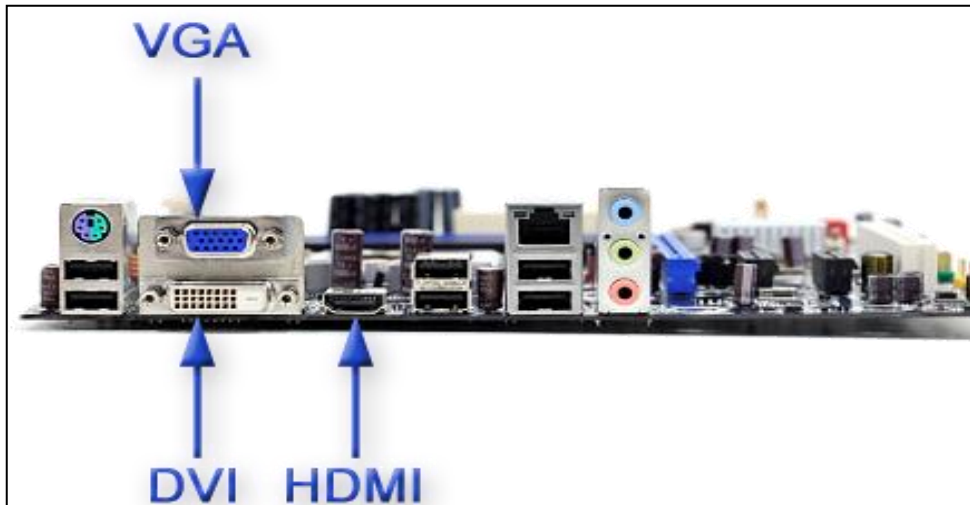

Figure 4.13 Monitor Connectors

Keyboard and Mouse are connected to the system in two ways

1. PS/2 (green for Mouse, blue for keyboard)
2. USB

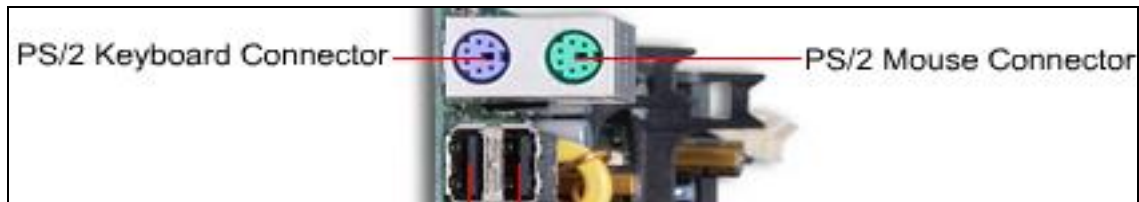

Figure 4.14 PS/2 and USB connector

Audio System and Head Phones are connected through Audio jack and USB also.



Figure 4.15 Audio Jack

Terminologies

21. Heat-sink المعادن التبريد
22. Fan مروحة
23. Screw driver مفك
24. Thermal grease الشحوم الحرارية
25. Front panel اللوحة الأمامية

Safety

- ⊛ Turn of power supply and disconnect power cable
- ⊛ Use anti-static electric discharge pads
- ⊛ Handle HDD very carefully
- ⊛ Remove the components and place them on safe area
- ⊛ Installed Processor with due care

Chapter 5

Microprocessor

AMD K10 Architecture

Red: Difference between K8 and K10 Architecture

(Die Änderungen zwischen der K8- und K10-Architektur sind rot markiert)

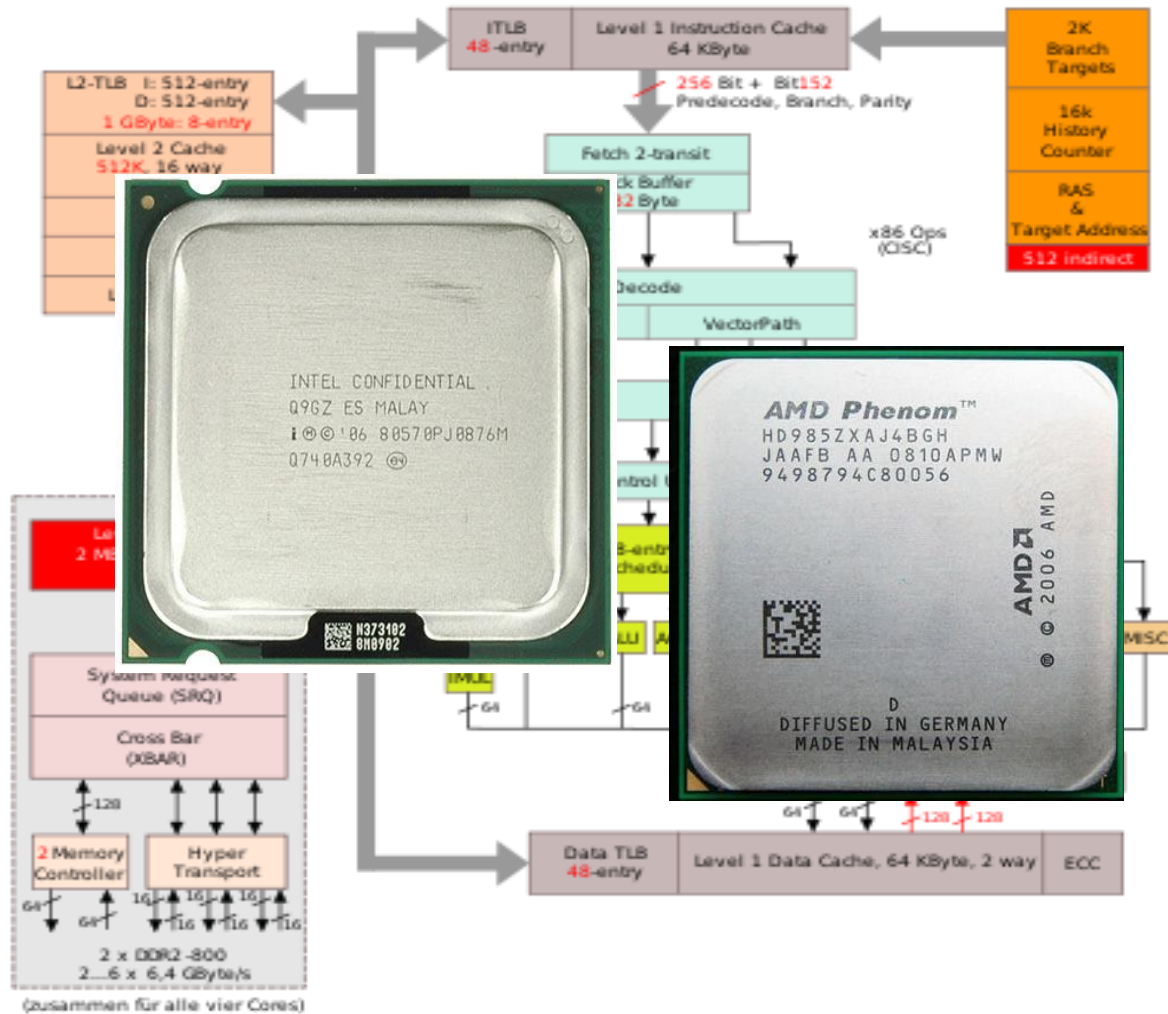

Objectives

- Understand Processor and its supporting components
- Understand bus Architecture
- Identify processor and its configuration
- Installation of Processor on Motherboard

Processor or Microprocessor

The brain or engine of the PC is the processor also called as microprocessor, or central processing unit (CPU). The CPU performs the system's calculating and processing. The processor is often the most expensive single component in the system.

Processors Specifications

- Speed of the Processor (Clock Speed) which is measured in MHz and GHz
- Speed of the Front Side Bus measured in MHz and GHz
- Address Bus
- Internal Registers
- Internal Cache Memory measured in MBs

Clock Speed is the number of cycles¹ per second (measured in hertz), the clock rate of a CPU is normally determined by the frequency of an oscillator crystal. The clock speed is the fastest speed at which a CPU can operate, determined by the CPU manufacturer.

The Intel 8088 processor had a clock speed of 4.77 MHz (4.77 million cycles per second), extremely slow by modern standards, but still a pretty big number compared to using a pencil and paper! CPUs today run at speeds in excess of 3 GHz (3 billion cycles per second).

1 hertz (1 Hz) = 1 cycle per second

1 megahertz (1 MHz) = 1 million cycles per second

1 gigahertz (1 GHz) = 1 billion cycles per second

The fundamental operation of most CPUs, regardless of the physical form they take, is to execute a sequence of stored instructions called a program. The *performance* or *speed* of a processor depends on the clock rate and the Instructions per Clock (IPC), which together are the factors for the Instructions per Second (IPS) that the CPU can perform.

Understand that a CPU's clock speed is its maximum speed, not the speed at which it must run. A CPU can run at any speed, as long as that speed does not exceed its clock speed.

8086 and 8088 processors take an average of 12 cycles to execute a single instruction.

286 and 386 processors improve this rate to about 4.5 cycles per instruction

486 and most other fourth-generation Intel-compatible processors, such as the AMD 5x86 2 cycles per instruction

Pentium Pro, Pentium II/III/4/D/Extreme Edition/Celeron, and Athlon/Athlon XP/Athlon 64/Athlon 64FX/Duron/Sempron three or more instructions per cycle.

Data Input Output or Front-Side Bus (FSB) is the bus that carries data between the CPU and the Northbridge. Throughput of the front-side bus is determined by the product of the width of its data path, its clock frequency (cycles per second) and the number of data transfers it performs per clock cycle. Data in a computer is sent as digital information in which certain voltages or voltage transitions occurring within specific time intervals represent data as 1s and 0s. You can increase the amount of data being sent (called *bandwidth*) by increasing either the cycling time or the number of bits being sent at a time, or both. Over the years, processor data buses have gone from 8 bits wide to 64 bits wide. All modern processors from the original Pentium and Athlon through the latest Core i7, AMD FX 83xx series, and even the Itanium series have a 64-bit (8-byte)-wide data bus. Therefore, they can transfer 64 bits of data at a time to and from the motherboard chipset or system memory.

For example, a 64-bit (8-byte) wide FSB operating at a frequency of 100 MHz that performs 4 transfers per cycle has a bandwidth of 3200 megabytes per second (MB/s). ($8 \times 100 \times 4 = 3200$).

Address Bus

The *address bus* is the set of wires that carry the addressing information used to describe the memory location to which the data is being sent or from which the data is being retrieved. As with the data bus, each wire in an address bus carries a single bit of information. This single bit is a single digit in the address. The more wires (digits) used in calculating these addresses, the greater the total number of address locations. The size (or width) of the address bus indicates the maximum amount of RAM a chip can address.

Computers use the binary (base 2) numbering system, so a two-digit number provides only four unique addresses (00, 01, 10, and 11), example if address bus is 8 bit to calculate number of addresses do the following.

$$2^8=2*2*2*2*2*2*2*2=256.$$

Intel processor with 40 bit address bus can handle 1TiB of address of RAM.

Internal Registers

Registers are internal memory location of the processor where data being processed and instruction is stored. The size of the internal registers indicates how much information the processor can operate on at one time and how it moves data around internally within the chip. This is sometimes also referred to as the internal data bus. Intel i7 processors have 8 32-bit mode registers and 16 64-bit mode registers. Both AMD and Intel currently produce the newest thing in micro processing 64-bit CPUs. A 64-bit CPU has general-purpose, floating point, and address registers that are 64 bits wide, meaning they can handle 64-bit-wide code in one pass—twice as wide as a 32-bit processor. And, they can address much, much more memory. With the 32-bit address bus of the Pentium and later CPUs, the maximum amount of memory the CPU can address is 2^{32} or 4,294,967,296 bytes. With a 64-bit address bus, CPUs can address 2^{64} bytes of memory, or more precisely, 18,446,744,073,709,551,616 bytes of memory—that's a lot of RAM. This number is so big that gigabytes and terabytes are no longer convenient, so we now go to an exabyte (2^{60}). A 64-bit address bus can address 16 exabytes of RAM. No 64-bit CPU uses an actual 64-bit address bus. Right now, the most RAM anybody uses is 4 GB, so there's not much motivation for creating a CPU or a motherboard that can handle and hold 16 EB. Every 64-bit processor gets its address bus "clipped" down to something reasonable. The Intel Itanium, for example, only has a 44-bit address bus for a maximum address space of 2^{44} , or 17,592,186,044,416 bytes. Initially, both AMD and Intel raced head with competing 64-bit processors. Interestingly, they took very different paths. Let's look at the two CPUs that made the first wave of 64-bit processing: the Intel Itanium and the AMD Opteron.

Cache Memory a CPU cache is a cache used by the central processing unit of a computer to reduce the average time to access memory, the cache is a smaller, faster memory which stores copies of the data which are most frequently used.

The cache on the CPU was called the L1 cache because it was the one the CPU first tried to use. The cache on the motherboard was called the L2 cache not because it was on the motherboard, but because it was the second cache the CPU checked. Later engineers took this cache concept even further and added the L2 cache onboard the CPU. A few CPU makers even went so far as to include three caches: an L1, an L2, and an L3 cache on the CPU. L3 caches are only seen on very powerful and specialized CPUs never on more common CPUs.

Clock Multiplier of CPU

All modern CPUs are clock multipliers. So in reality, every CPU now has two clock speeds: the speed that it runs internally and the speed that it runs when talking on the address bus and the external data bus (Front Side Bus). Multipliers run from $2\times$ up to almost $30\times$. Multipliers do not have to be whole numbers. You can find a CPU with a multiplier of $6.5\times$ just as easily as you would find one with a multiplier of $7\times$. A late-generation Pentium would have an external speed of 66 MHz (FSB) multiplied by $4.5\times$ for an internal speed of 300 MHz

GPU: Graphics Processing Unit is a specialized processor that offloads 3D or 2D graphics rendering from the microprocessor. In a personal computer, a GPU can be present on a video card, or it can be on the motherboard, core processor of Intel has GPU inside the processor. Example Core i7 6920HQ have GPU HD Graphics 530 embedded in the processor die.

GPU-accelerated computing is the use of a graphics processing unit (GPU) together with a CPU to accelerate scientific, analytics, engineering, consumer, and enterprise applications. Pioneered in 2007 by NVIDIA, GPU accelerators now power energy-efficient datacenters in government labs, universities, enterprises, and small-and-medium businesses around the world. GPUs are accelerating applications in platforms ranging from cars, to mobile phones and tablets, to drones and robots. GPU-accelerated computing offers unprecedented application performance by offloading compute-intensive portions of the application to the GPU, while the remainder of the code still runs on the CPU. From a user's perspective, applications simply run significantly faster

Thermal design power (TDP), sometimes called **thermal design point**, refers to the maximum amount of power the cooling system in a computer is required to dissipate. Example Core i7 3770T require 45 Watts.

Intel Turbo Boost is a technology implemented by Intel in certain models of Core i5 and Core i7 that enables the processor to run above its base operating frequency via dynamic control of the CPU's "clock rate". It is activated when the operating system requests the highest performance state of the processor.

Advanced Encryption Standard (AES) Instruction Set is an extension to the x86 instruction set architecture for microprocessors from Intel and AMD. The purpose of the instruction set is to improve the speed of applications performing encryption and decryption using the Advanced Encryption Standard (AES).

Intel virtualization (VT-x). is the Virtualization Technology from Intel. Hardware Virtualization² is the facility that allows multiple operating systems to simultaneously share processor resources in a safe and efficient manner.

MMX Technology

In 1996, Intel added a new enhancement to its CPU, called multimedia extensions (MMX), in response to the large number of programs with heavy graphic needs coming out at this time. MMX was designed to work with large graphics by calculating on large chunks of data and performing vector math (vector math is needed to handle graphical issues such as spinning a (3D object).

SSE, SSE2, and SSE3

In February 1999, Intel introduced the Pentium III processor and included in that processor an update to MMX called Streaming SIMD Extensions (SSE). Advantages of SSE are as follows

- Higher resolution and higher quality image viewing and manipulation for graphics software
- High-quality audio, MPEG2 video, and simultaneous MPEG2 encoding and decoding for multimedia applications
- Reduced CPU utilization for speech recognition, as well as higher accuracy and faster response times when running speech-recognition software

SSE2 is an extension to SSE and SSE3 is an extension to SSE2.

3DNow

3DNow technology was originally introduced as AMD's alternative to the SSE instructions in the Intel processors.

Hyper-Threading Technology

Computers with two or more physical processors have long had a performance advantage over single-processor computers when the operating system supported multiple processors, as is the case with Windows NT 4.0, 2000, XP Professional, and Linux. However, dual-processor motherboards and systems have always been more expensive than otherwise-comparable single processor systems, and upgrading a dual-processor-capable system to dual-processor status can be difficult with only one processor because of the need to match processor speeds and specifications. However, Intel's Hyper-Threading (HT) Technology allows a single processor to handle two independent sets of instructions at the same time. In essence, HT Technology converts a single physical processor into two virtual processors. Intel originally introduced HT Technology in its line of Xeon processors for servers in March 2002.

Core Architecture³ CPUs

CPU clock speeds hit a practical limit of roughly 4 GHz around 2002–2003, motivating the CPU makers to find new ways to get more processing power for CPUs. Dual-core isn't just two CPUs on the same chip. A dual-core CPU has two execution units two sets of pipelines but the two sets of pipelines share caches and RAM.

Intel introduced Dual core with Pentium D line of processor. The Pentium D is simply two late-generation

Pentium 4s molded onto the same chip with each CPU using its own cache although they do share the same front side bus. There are two codenames for Pentium D processors: the "Smithfield" (model numbers 8xx), using a 90-nm process, and the "Presler" (model numbers 9xx), using a 65-nm process. Pentium Ds use the LGA (Land Grid Array) 775 socket.

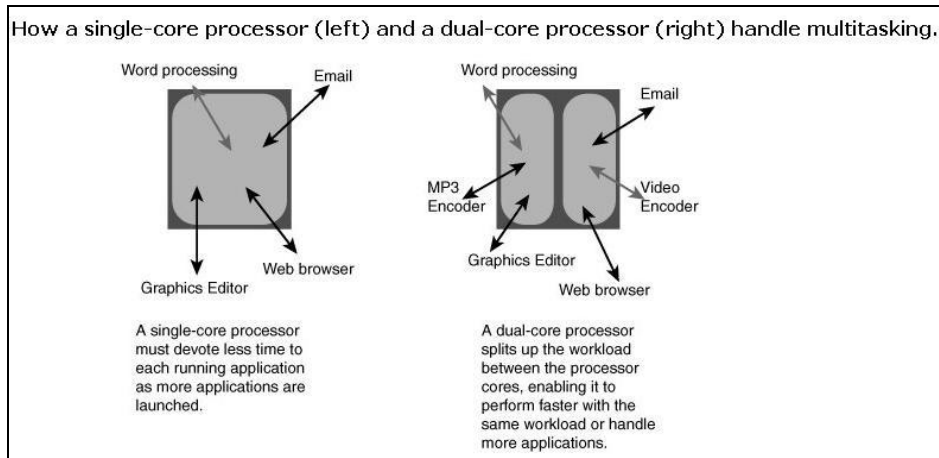

Figure 5.1 Core Processor design

Intel Core Processor Family Brand Names

Core solo
Core Duo
Core2 Solo
Core2 Duo
Core2 Quad
Core2 Extreme
Core i3, Core i5, Core i7,

Intel Core 2

In Year 2006 With the Core 2 line of processors, Intel released radically revised processor architecture, called Core Architecture. Redesigned to maximize efficiency, and low power consumption.

Some of the models of Core2 Processors are given below for complete list Refer to Intel Processor List

Model Number	Spec Number	Frequency	L2 Cache	FSB	Multiplier	Socket	Release Date
<u>Core 2 Duo E4300</u>	<u>SL9TB</u> (L2) <u>SLA99</u> (M0)	1800 MHz	2 <u>MB</u>	800 MT/s	9×	<u>LGA 775</u>	January 21, 2007
<u>Core 2 Duo E4400</u>	<u>SLA3F</u> (L2) <u>SLA98</u> (M0)	2000 MHz	2 MB	800 MT/s	10×	LGA 775	April 22, 2007
<u>Core 2 Duo E4500</u>	<u>SLA95</u> (M0)	2200 MHz	2 MB	800 MT/s	11×	LGA 775	July 22, 2007

Core i3, i5, i7 are the based on Intel Nehalem architecture, Nehalem Processor are more energy efficient than other core processors and *Hyper Threading* is reintroduced here along with L3 cache.

Model Number	Spec Number	Frequency	L2 Cache	L3 Cache	Cores	Socket	Memory	Release Date
Core i3 530	SLBLR (C2)	2933 MHz	2 *256 KB	4 MB	2	LGA 1156	2*DDR3 1333	January 7, 2010
Core i3 330E	SLBQC (C2)	2133 MHz	2*256 KB	3 MB	2	BGA 1288	2*DDR3 1066	January 7 2010
Core i5 2550 K	SROQH (D2)	3.4 GHz	4 × 256 KB	6 MB	4	LGA 1155	2 × DDR3-1333	January 2012
Core i7-3770T	SR0PQ (E1)	2.5 GHz	4 × 256 KB	8 MB	4	LGA 1155	4* DDR3-1600	April 2012

Intel has introduced many other processors with different micro-architectures, westmere, SandyBridge, ivy Bridge, Haswell, Broadwell, and new **Skylake** line of processor in August 2015.

Model Number	GPU	Frequency	L2 Cache	L3 Cache	Cores	Socket	Memory	Release Date
Core i3 6300	HD530	3.8GHz	2*256 KB	4 MB	2	LGA 1151	2*DDR4 1866/1600	September 2015
Core i5 5675C	Iris Pro Graphics 6200	3.21GHz	4*256 KB	4MB	4	LGA 1150	DDR3L-1333/1600	June 2015
Core i5 6500	HD530	3.2 GHz	4*256 KB	6MB	4	LGA 1151	DDR4-1866/2133, DDR3L-1333/1600	September 2015
Core i7 5775C	Iris Pro Graphics 6200	3.3GHz	4*256 KB	6MB	4	LGA 1150	DDR3L-1333/1600	June 2015
Core i7 6700K	HD530	4 GHz	4*256 KB	8MB	4	LGA 1151	DDR4-1866/2133, DDR3L-1333/1600	September 2015

Brand Name: Core i3, i5, i7 are the brand name it applies to the family of desktop and laptop processors.

Code Name: westmere (1st generation), SandyBridge (2nd generation), ivy Bridge (3rd generation), Haswell (4th generation), Broadwell (5th generation) and new **Skylake (6th generation)**

Model Number: Model number of processor is given to processor, model number also describes its code name and brand name eg: core **i7 5775C**

How to identify the model and Specifications of the Processor

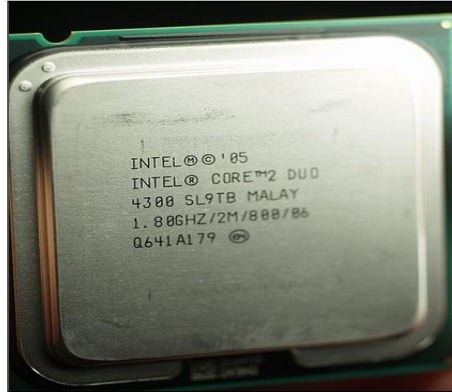

Information on the Chip

Intel Core2 Duo [Brand Name]

4300 SL9TB [Model]

MALAY [Country where Manufactured]

1.80 GHz/2M/800/06 [Speed=1.80, Cache=2MB, FSB=800 MHz, Year of manufacturing=2006]

Q641A179 [Part Number]

Figure 4.2 Intel Processor

Advanced Micro Devices (AMD) Processors

AMD is another manufacturer of micro processor which is having respectable share in the market.

Model	Clock rate	Cache	Memory	Socket	Release
Opteron Quad-core Lisbon	2.2 GHz (4122), 2.6 GHz (4130)	L3-Cache 6 MB	DDR3 1333 MHz	Socket C32	June 23, 2010
Opteron 8 core Zurich (3280)	2.4 GHz	L3 8MB	DDR3 1866 MHz	Socket AM3+	March 20, 2012
Athlon II Propus	3.1 GHz	L2 512 kB per core	DDR3 1333 MHz	Socket AM3	Sep 2009

AMD release processors in different models and lines with different micro-architectures Processor lines of AMD are **Opteron, Phenom, Athlon, Turion, Sempron**. And micro architectures like K7 Architecture, K8 Core Architecture, K-10 Core Architecture and Bobcat Core architecture.

Server Processors

Intel Xeon Processors				
Code-named	Core		Date released	
Sossaman	dual	(65 nm)	Mar	2006
Woodcrest	dual	(65 nm)	Jun	2006
Conroe	dual	(65 nm)	Oct	2006
Allendale	dual	(65 nm)	Jan	2007
Wolfdale	dual	(45 nm)	Feb	2008
Kentsfield	quad	(65 nm)	Jan	2007
Yorkfield	quad (45 nm)		Mar	2008
Wolfdale	DP	dual (45 nm)	Nov	2007
Clovertown		quad (65 nm)	Nov	2006
Harpertown		quad (45 nm)	Nov	2007
Nehalem-EP		dual/quad (45 nm)	Mar	2009
Bloomfield		quad (45 nm)	Mar	2009
Beckton	(65xx)	quad/six/eight (45 nm)	Mar	2010
Westmere-EX	(E7-2xxx)	six/eight/ten (32 nm)	Apr	2011
Sandy Bridge-EP		dual/quad/six/eight (32 nm)	Mar	2012

AMD Server Processors				
Processor Series	Model	Frequency	wattage	Cores
AMD Opteron 6200 Series	6282 SE	2600	140 W	16
AMD Opteron 6200 Series	6238	2600	115 W	12
AMD Opteron 4200 Series	4276 HE	2600	65 W	8

Laptops and Notebooks also have a different range of processor like from Intel Atom Processors and Mobile Series processor and from AMD Athlon neo AMD fusion are designed for notebooks, other manufacturer like ARM also launched lower power and energy efficient processors for laptop and notebook market.

Terminologies

26. Cycles دورات
27. Virtualization الافتراضية
28. Architecture أسلوب بناء

Chapter 6

Secondary Storage Devices

HDD

Solid State Drives



Objectives

- Assemble and Disassemble the HDD, CD/DVD
- Partition and Format HDD
- Use of different HDD tools

Definition of a Hard Disk

For Many users, the hard disk drive is the most important and yet the most mysterious part of a computer system. A hard disk drive is a sealed unit that a PC uses for nonvolatile data storage. Nonvolatile, or semi-permanent, storage means that the storage device retains the data even when no power is supplied to the computer. Because the hard disk drive is expected to retain data until deliberately erased or overwritten, the hard drive is used to store crucial programming and data. As

a result, when the hard disk fails, the consequences are usually very serious. To maintain, service, and upgrade a PC system properly, you must understand how the hard disk functions.

A hard disk drive contains rigid, disk-shaped platters¹, usually constructed of aluminum or glass unlike floppy disks, the platters can't bend or flex hence the term hard disk. In most hard disk drives, you can't remove the platters, which is why they are sometimes called fixed disk drives. Removable hard disk drives are also available. Usually, this term refers to a device in which the entire drive unit (that is, the disk unit containing the platters as well as the rest of the drive) is removable, but it can also refer to cartridge drives, where the platters are contained in a removable cartridge.

Hard Disk Drive Operation

The basic physical construction of a hard disk drive consists of spinning disks with heads that move over the disks and store data in tracks² and sectors³. The heads read and write data in concentric rings called tracks, which are divided into segments called sectors, which typically store 512 bytes each

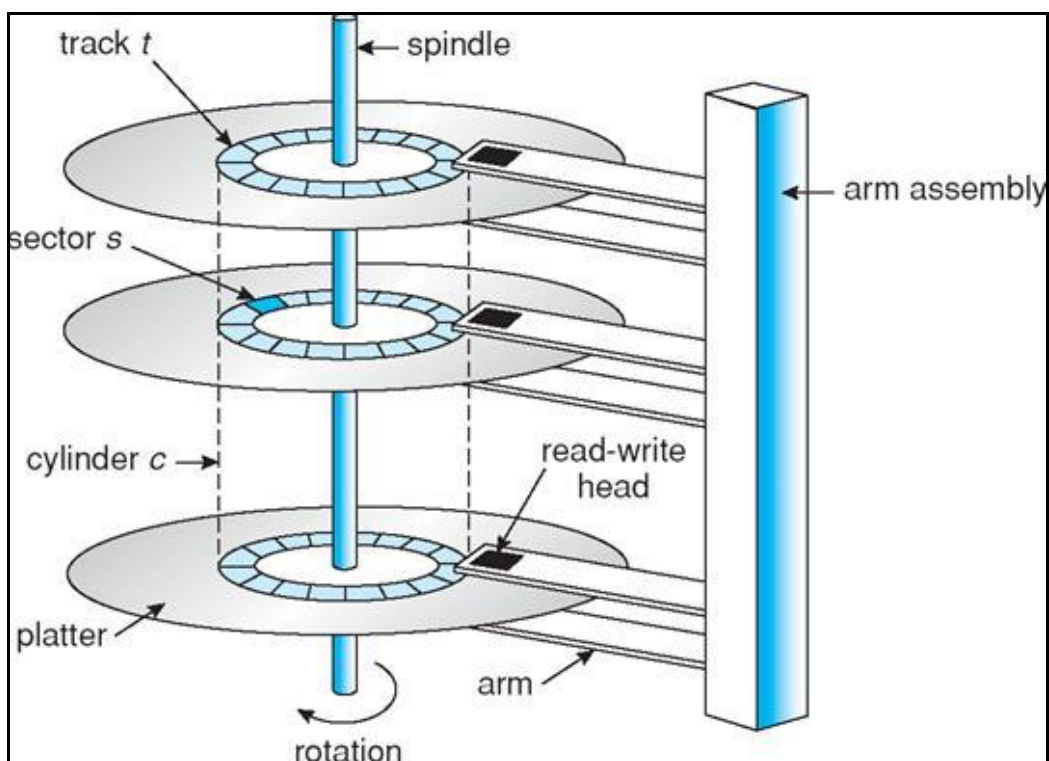

Figure 6.0 track and sectors

Hard disk drives usually have multiple disks, called platters, that are stacked on top of each other and spin in unison, each with two sides on which the drive stores data. Most drives have two or three platters, resulting in four or six sides, but some PC hard disks have up to 12 platters and 24 sides with 24 heads to read them (Seagate Barracuda 180). The identically aligned tracks on each side of every platter together make up a cylinder⁴ a hard disk drive usually has one head per platter side, with all the heads mounted on a common carrier device or rack. The heads move radially across the disk in unison, they can't move independently because they are mounted on the same carrier or rack, called an actuator.

Originally, most hard disks spun at 3,600rpm approximately⁵, now, however, most drives spin even faster. Although speeds can vary, modern drives typically spin the platters at either 4,200rpm; 5,400rpm; 7,200rpm; 10,000rpm; or 15,000rpm.

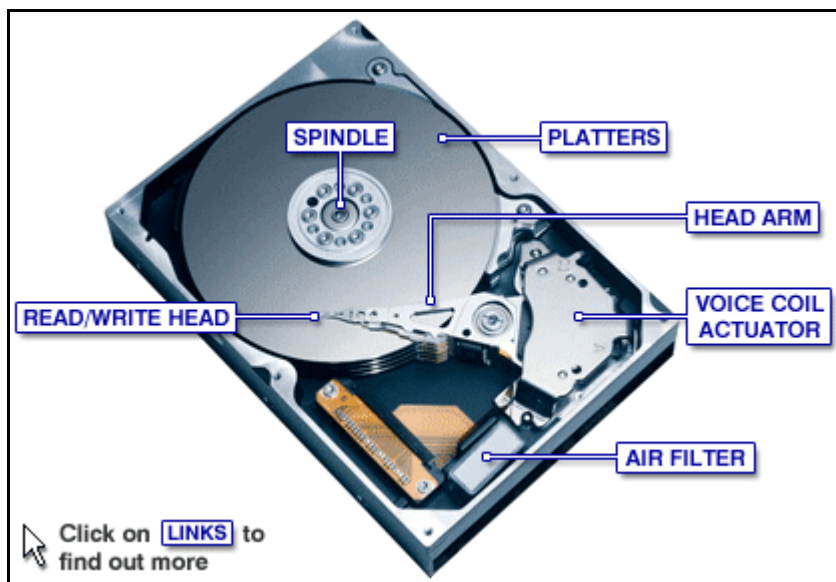

Figure 6.1 HDD Components

An Overview of the IDE Interface

The interface⁶ used to connect hard disk and optical drives to a modern PC is typically called IDE (Integrated Drive Electronics). Although ATA (Advance Technology Attachment) is the official name of the interface, IDE is a marketing term originated by some of the drive manufacturers to describe the drive/controller combination used in drives with the ATA interface.

ATA was originally a 16-bit parallel interface, meaning that 16 bits are transmitted simultaneously down the interface cable. A newer interface, called Serial ATA, was officially introduced in late 2000 and was adopted in desktop systems starting in 2003 and in laptops starting in late 2005. Serial ATA (SATA) sends 1 bit down the cable at a time, enabling thinner and smaller cables to be used, as well as providing higher performance due to the higher cycling speeds it enables. SATA is a completely new and updated physical interface design, while remaining compatible on the software level with Parallel ATA. Throughout this book, ATA refers to either just the parallel or both the parallel and serial versions, whereas Parallel ATA (PATA) refers specifically to the parallel version and Serial ATA (SATA) refers specifically to the serial version.

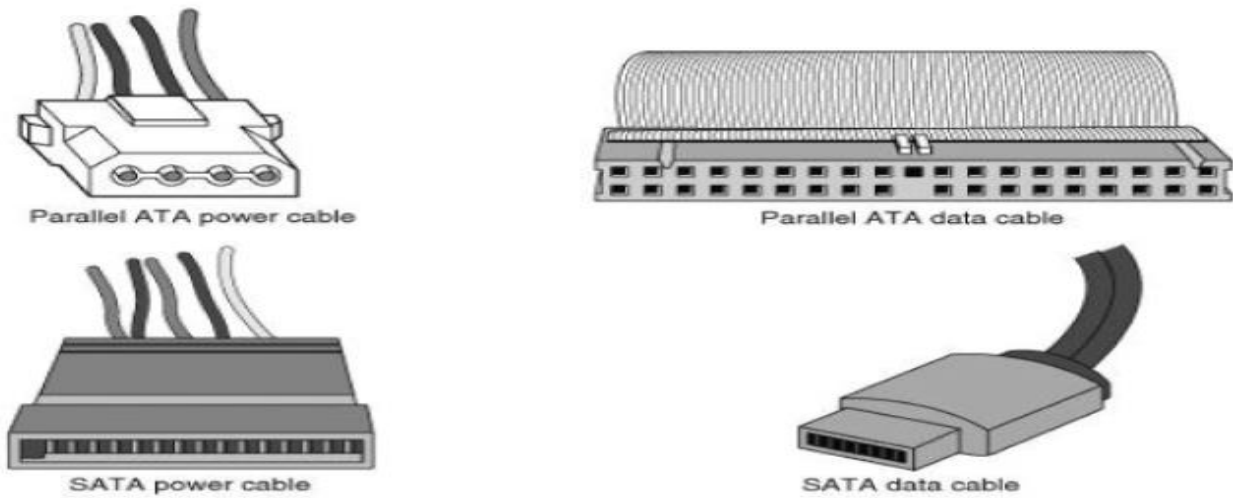

Figure 6.2 Interfaces

Parallel ATA I/O Connector

The parallel ATA interface connector is normally a 40-pin header-type connector with pins spaced 0.1" (2.54mm) apart, and generally it is keyed to prevent the possibility of installing it upside down. To create a keyed connector, the manufacturer usually removes pin 20 from the male connector and blocks pin 20 on the female cable connector, which prevents the user from installing the cable backward.

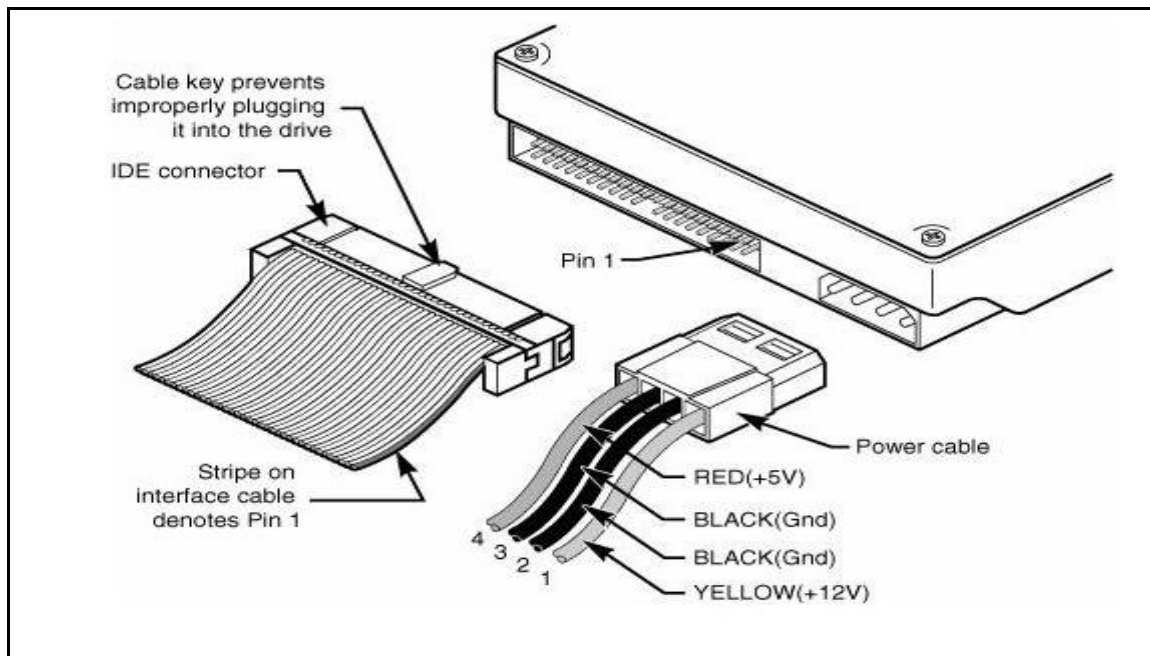

Figure 6.3 Parallel ATA

Disk Formatting

Two formatting⁷ procedures are required before you can write user data to a disk:

- Physical, or low-level formatting
- Logical, or high-level formatting

A hard disk, however, requires two separate formatting operations. Moreover, a hard disk requires a third step, between the two formatting procedures, to write the partitioning information to the disk. Partitioning is required because a hard disk is designed to be used with more than one operating system. Using multiple operating systems on one hard drive is possible by separating the physical formatting in a procedure that is always the same, regardless of the operating system used and the high-level format (which is different for each operating system). Partitioning enables a single hard disk drive to run more than one type of operating system, or it can enable a single operating system to use the disk as several volumes or logical drives. A volume or logical drive is any section of the disk to which the operating system assigns a drive letter or name.

Consequently, preparing a hard disk drive for data storage involves three steps:

1. Low-Level Formatting
2. Partitioning
3. High-Level Formatting

Low-Level Formatting

During a low-level format, the formatting program divides the disk's tracks into a specific number of sectors, creating the intersector and intertrack gaps and recording the sector header and trailer information. The program also fills each sector's data area with a dummy byte value or a pattern of test values. For hard disks, the number of sectors per track depends on the drive and the controller interface.

The original ST-506/412 MFM controllers always placed 17 sectors per track on a disk, although ST-506/412 controllers with RLL encoding increased the number of sectors to 25 or 26 per track; ESDI drives had 32 or more sectors per track. The ATA/IDE and SCSI drives found in PCs today can have anywhere from 17 to 900 or more sectors per track.

New Hard Disk Drives comes with ready LLF

Partitioning

Creating a partition⁸ on a hard disk drive enables it to support separate file systems, each in its own partition.

Each file system can then use its own method to allocate file space in logical units called clusters or allocation units. Every hard disk drive must have at least one partition on it and can have up to four partitions, each of which can support the same or different type file systems. Three common file systems are used by PC operating systems today:

- FAT⁹ (file allocation table). The standard file system supported by DOS and Windows 9x/Me. FAT partitions support filenames of 11 characters maximum (8 characters + a 3-character extension) under DOS, and 255 characters under Windows 9x (or later). The

standard FAT file system uses 12- or 16-bit numbers to identify clusters, resulting in a maximum volume size of 2GB.

Using FDISK, you can create only two physical FAT partitions on a hard disk drive primary and extended but you can subdivide the extended partition into as many as 25 logical volumes. Alternative partitioning programs, such as Partition Magic, can create up to four primary partitions or three primary and one extended.

- FAT32 (file allocation table, 32-bit). An optional file system supported by Windows 95 OSR2 (OEM Service Release 2), Windows 98, Windows Me, and Windows 2000/XP.

FAT32 uses 32-bit numbers to identify clusters, resulting in a maximum single volume size of 2TB or 2,048GB.

- NTFS (Windows NT File System). The native file system for Windows NT/2000/XP that supports filenames up to 256 characters long and partitions up to (a theoretical) 16 exabytes. NTFS also provides extended attributes and file system security features that do not exist in the FAT file system.

Up until the release of XP, FAT32 was by far the most popular file system. Because NTFS is native to XP, NTFS is now more popular in newer systems. Still, the FAT file system is accessible by nearly every operating system, which makes it the most compatible in a mixed OS environment. FAT32 and NTFS provide additional features but are not universally accessible by other operating systems.

Partitioning normally is accomplished by running the disk partitioning program that comes with your operating system or you can download free Disk Mangers. You usually should have as few partitions as possible, and many people (myself included) try to stick with only one or two at the most. This was more difficult before FAT32 because the maximum partition size for a FAT16 partition was only 2GB. With FAT32, though, the maximum partition size can be up to 2048GB.

High-Level Formatting

During the high-level format, the operating system writes the structures necessary for managing files and data on the disk. For example, FAT partitions have a Volume Boot Sector (VBS), two copies of a file allocation table (FAT), and a root directory on each formatted logical drive. These data structures enable the operating system to manage the space on the disk, keep track of files, and even manage defective areas so they do not cause problems.

High-level formatting is not really a physical formatting of the drive, but rather the creation of a table of contents for the disk. In low-level formatting, which is the real physical formatting process, tracks and sectors are written on the disk. As mentioned, the DOS and Windows 9x/Me `FORMAT` command can perform both low-level and high-level format operations on a floppy disk, but it performs only the high-level format for a hard disk. Low-level formats of ATA and SCSI hard disk drives are performed by the manufacturer and should almost never be performed by the end user. The only time I low-level format ATA or SCSI drives is when I am attempting to repair a format that has become damaged (parts of the disk become unreadable) or in some cases when I want to wipe away all data on the drive.

Hard Disk Partitioning and Formatting

It can be done as follows

1. Using Disk manager program specific to HDD manufacturer
2. Using Operating System Disc.
3. Disk Partitioning and formatting Utilities.

Hard Disk Drive Form Factors

Form factor	Width (mm)	Largest capacity	Platters (max)	Per platter (GB)
3.5"	102	4 TB (2011)	5	1000 GB
2.5"	69.9	2 TB (2012)	4	500 GB
1.8"	54	320 GB (2009)	2	160 GB



Figure 6.4 HDD 1.8 “2.5” and 3.5”

HDD 2.5” and 1.8” are used in Notebook and Laptop Computers and 3.5” in Desktop Computers.

HDD Features

- Capacity
- Performance
- Reliability

Capacity¹¹

How big a hard drive you can use depends somewhat on the interface you choose. Although the ATA interface is by far the most popular interface for hard drives, SCSI interface drives are also available. Each has different limitations, but those of ATA have always been lower than those of SCSI.

If your motherboard ROM BIOS dates before 1998 and is limited to 8.4GB or dates before 2002 and is limited to 137GB, and you want to install a larger drive, I recommend you first contact your motherboard (or system) manufacturer to see whether an update is available. Virtually all motherboards incorporate a flash ROM, which allows for easy updates via a utility program.

Internal ATA drives larger than 137GB require 48-bit logical block address (LBA) support. This support must be provided in the operating system; it can also be provided in the BIOS, or both. It is best if both the OS and the BIOS support it, but it can be made to work if only the OS has the support.

48-bit LBA support in the OS requires

- Windows XP with Service Pack 1 (SP1) or later.
- Windows 2000 with Service Pack 4 (SP4) or later.
- Windows 98/98SE/Me or NT 4.0 with the Intel Application Accelerator (IAA) loaded. This solution works only if your motherboard has an IAA-supported chipset

Performance¹²

When you select a hard disk drive, one of the important features you should consider is the performance (speed) of the drive. Speed is measured in two ways.

- Transfer Rate
- Average Access Time

Don't be fooled by interface transfer rate hype, especially around ATA-133 or SATA-150. A far more important gauge of a drive's performance is the average media transfer rate, which is significantly lower than the interface rate of 133MBps or 150MBps. The media transfer rate represents the average speed at which the drive can actually read or write data. The rotational speed of the drive has the biggest effect on the drive's true transfer speed; in general, drives that spin at 10,000rpm transfer data faster than 7,200rpm drives, and 7,200rpm drives transfer data faster than those that spin at 5,400rpm. Media transfer rates have minimum and maximum figures because drives today use zoned recording with fewer sectors per track on the inner cylinders than the outer cylinders.

When you know the sector per track (SPT) and rotational speed figures, you can use the following formula to determine the true media data transfer rate in millions of bytes per second (MBps):

Media Transfer Rate (MBps) = $SPT \times 512 \text{ bytes} \times \text{rpm} / 60 \text{ seconds} / 1,000,000 \text{ bytes}$

For example, the Hitachi Deskstar 120GXP drive spins at 7,200rpm and has an average of 688 sectors per track. The average media transfer rate for this drive is figured as follows:

$$688 \times 512 \times (7,200 / 60) / 1,000,000 = 42.27 \text{ MBps}$$

Average seek time, usually measured in milliseconds (ms), is the average amount of time it takes to move the heads from one cylinder to another a random distance away.

Latency is the average time (in milliseconds) it takes for a sector to be available after the heads have reached a track. On average, this figure is half the time it takes for the disk to rotate once. A drive that spins twice as fast would have half the latency.

Drives today spin at 7,200rpm, resulting in a latency time of only 4.17ms, whereas others spin at 10,000rpm or even 15,000rpm, resulting in incredible 3.00ms or 2.00ms.

Average Access Time

A measurement of a drive's average access time is the sum of its average seek time plus latency. The average access time is usually expressed in milliseconds.

A measurement of a drive's average access time (average seek time plus latency) provides the average total amount of time required for the drive to access a randomly requested sector.

Reliability¹³

Mean time Between Failures (MTBF) is used to measure the reliability of the drive. MTBF is the failure rate for previous drive models with the same components and calculate a failure rate for a new drive based on the components used to build the drive assembly. If a drive claims to have an MTBF of 500,000 hours, you can expect a failure in that population of drives in 500,000 hours of total running time.

Self-Monitoring, Analysis, and Reporting Technology (**SMART**) is an industry standard providing failure prediction for disk drives. When SMART is enabled for a given drive, the drive monitors predetermined attributes that are susceptible to or indicative of drive degradation. Based on changes in the monitored attributes, a failure prediction can be made. If a failure is deemed likely to occur, SMART makes a status report available so the system BIOS or driver software can notify the user of the impending problems, perhaps enabling the user to back up the data on the drive before any real problems occur.

Solid State Drives¹⁴

Also known as electronic disk uses integrated circuit (ICs) assemblies as memories. Uses NAND based flash technology. There are no electro-mechanical components like magnetic HDD, which makes it faster with lower access time and latency time. It produces no noise from the drive and less vulnerable to shock.

As previously mentioned, SSDs use NAND flash technology. Two subtypes of this technology are used in commercially available SSDs: SLC (single-level cell) and MLC (multilevel cell). SLC flash stores 1 bit in a single cell, whereas MLC stores 2 or more bits in a single cell. MLC doubles

(or more) the density, and consequently lowers the cost, but this comes at a penalty in performance and usable life. SSDs are available using either technology, with SLC versions offering higher performance, lower capacity, and higher cost. Most mainstream SSDs use MLC technology. Whereas more specialized high-end products (mostly for server or workstation systems) use SLC. Available in form factors like 1.8 and 2.5 inch and a wide range of capacities 40GB, 80GB, 120GB, 160GB, 300GB, or 600GB capacity. Interfaces used by SSD are SATA and PCIe (card based).

Intel has released range of SSDs given below are few.

SSD	Capacity	Read/Write	Form Factor
Intel 320 series SSD	600 GB	200 MB/s 45 MB/s	2.5 inch 1.8 inch SATA
Intel 710 series SSD	300 GB	270 MB/s 210 MB/s	2.5 inch SATA
Intel 910 series SSD	800 GB	2 GB/s 1GB/s	PCIe card
Intel P3608 series	1.6 TB	5000 MB/s	PCIe AIC



Figure 6.5 Intel SSD 320



Figure 6.6 SSD 910 PCIe

SCSI

Small Computer System Interface Drives are high performance and capacity drives used in servers and high-end workstations even if you plan to use more than 4 drives SCSI is more suitable.

Interfaces and transfer rates of SCSI

SCSI type	Data Transfer Rate
SCSI 1	5 MB/s
SCSI 2	10 MB/s
SCSI 3	20MB/s to 160 MB/s
Serial Attached 2.0 SCSI	600 MB/s
FC-AL SCSI (Fiber Channel Arbitrated Loop)	100 MB/s to 400 MB/s
iSCSI (internet SCSI)	Base on Network speed

Safety

- ⊛ Turn-off power
- ⊛ Disassemble Hard Disk Drive carefully
- ⊛ Place HDD on safe area

Terminologies

- 29. Platters صحون
- 30. Track المسارات
- 31. Sector القطاعات
- 32. Cylinder أسطوانة
- 33. Approximately ما يقرب من
- 34. Interface وسيط
- 35. Formatting التنسيق
- 36. Partition قسم
- 37. FAT (File Allocation Table)
- 38. Manufacturer جدول تخصيص الملفات
- 39. Capacity سعة
- 40. Performance إنجاز
- 41. Reliability صلابة
- 42. Solid state drives

Chapter 7

Primary Memories

DDR

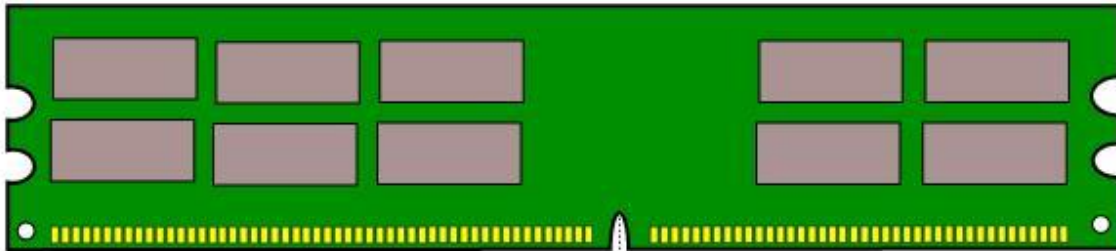

DDR 2

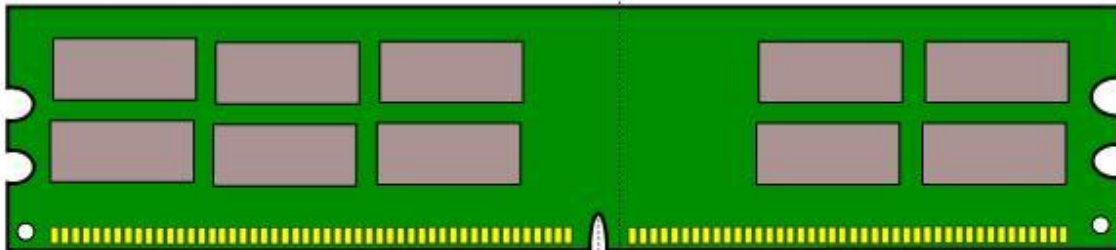

DDR 3

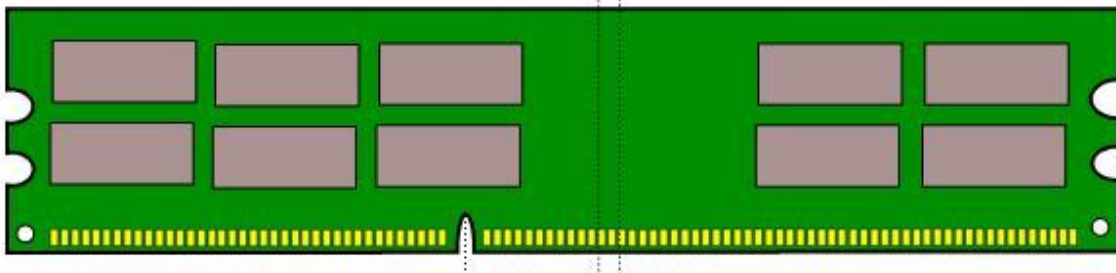

Objectives

- Understand Primary Memory
- Identify Different Memories and their Specifications
- Install and Upgrade Memories
- Troubleshoot Memories

Memory¹ of computer is a storage area and there are many types of memories with different purpose. Basically we can categorize memory in to Main memory and Secondary memory.

Main Memories²

- RAM
- ROM
- Cache

Secondary Memories³ (Secondary Storages)

- Hard disk
- CD/DVD disk
- Floppy
- USB Drive (pen drive, flash drive)
- Tape Drive

Main Memory: is the workspace for the computer's processor where the programs and data being operated on by the processor must reside. Main memory can also be referred as Primary Memory.

Secondary Memory: is the storage area, where we store the data for a long time.

Why we need different types of memories in our computer?

When processor wants to perform any job it needs program (instructions) and Data, programs like windows operating system, Microsoft word etc. Data like files and folders. All of the programs and Data reside in the permanent secondary storage device (Hard disk) transferring data between hard disk and processor is logical because processor bus and hard disk data transfer rates are quite different.

For example Pentium 4 processor with bus speed 800 MHz means transfers 6400 MBps and a Hard disk 133 MBps .RAM and Cache are used to improve the performance. Speed of RAM is nearly equal to processor bus speed and cache runs at the same speed of processor bus.

Figure given below illustrate you the concept of data path⁴.

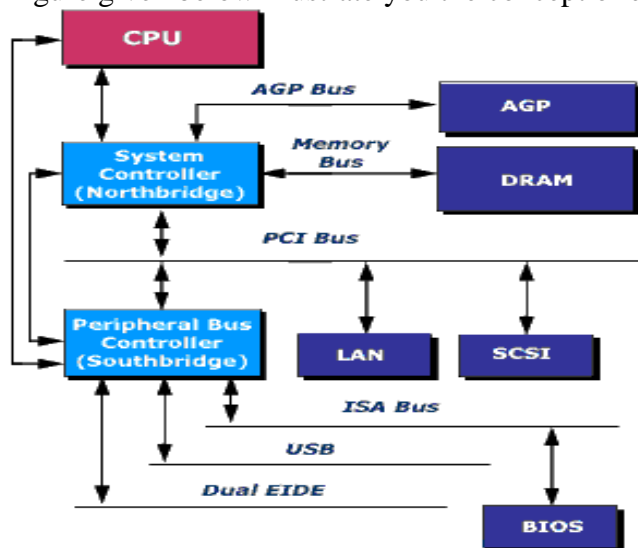

Figure 7.1 Data path

RAM means Random Access Memory it is also known as Primary memory or main memory all the programs and data reside here in this memory while your computer is running.

RAM Technologies

Dynamic RAM (DRAM) is the type of memory chip used for most of the main memory in a modern PC. The main advantages of DRAM are that it is very dense, meaning you can pack a lot of bits into a very small chip, and it is inexpensive, which makes purchasing large amounts of memory affordable.

The memory cells in a DRAM chip are tiny capacitors that retain a charge to indicate a bit. The problem with DRAM is that it is dynamic. Also, because of the design, it must be constantly refreshed; otherwise, the electrical charges in the individual memory capacitors will drain and the data will be lost. Refresh time is 15ms (milliseconds).

Static RAM (SRAM) it is significantly faster than most types of DRAM. SRAM stands for static RAM, which is so named because it does not need the periodic refresh rates like DRAM. Because of how SRAMs are designed, not only are refresh rates unnecessary, but SRAM is much faster than DRAM and much more capable of keeping pace with modern processors.

Fast Page Mode RAM (FPM RAM) it uses Paging which enables faster access to all the data within a given row of memory by keeping the row address the same and changing only the column. Memory that uses this technique is called Page Mode or Fast Page Mode memory.

Extended Data out RAM a modified form of FPM memory,

SDRAM

SDRAM is short for synchronous DRAM, a type of DRAM that runs in synchronization with the memory bus. SDRAM delivers information in very high-speed bursts using a high-speed, clocked interface. SDRAM removes most of the latency involved in asynchronous DRAM because the signals are already in synchronization with the motherboard clock.

DDR SDRAM

Double Data Rate (DDR) SDRAM memory is the upgrade of standard SDRAM in which data is transferred twice as quickly. Instead of doubling the actual clock rate, DDR memory achieves the doubling in performance by transferring twice per transfer cycle, once at the leading (falling) edge and once at the trailing (rising) edge of the cycle.

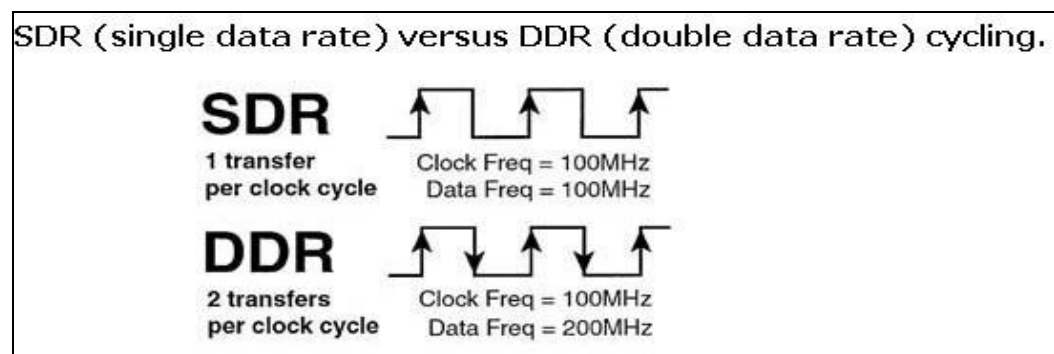

Figure 7.2 SDR DDR cycling

DDR SDRAM uses a DIMM (Dual inline Memory module) module design with 184 pins.

Types of standard DDR SDRAM modules

Module Standard	Chip Type	Clock Speed (MHz)	Cycles per Clock	Bus Speed (MT/s)	Bus Width (Bytes)	Transfer Rate (MBps)
PC1600	DDR200	100	2	200	8	1,600
PC2100	DDR266	133	2	266	8	2,133
PC2400	DDR300	150	2	300	8	2,400
PC2700	DDR333	166	2	333	8	2,667
PC3000	DDR366	183	2	366	8	2,933
PC3200	DDR400	200	2	400	8	3,200
PC3500	DDR433	216	2	433	8	3,466
PC3700	DDR466	233	2	466	8	3,733
PC4000	DDR500	250	2	500	8	4,000
PC4200	DDR533	266	2	533	8	4,266

MT/s = Mega transfers per second

MBps = Megabytes per second

DIMM = Dual inline memory module

DDR = Double data rate

DDR2 SDRAM

DDR2 SDRAM is simply a faster version of conventional DDR-SDRAM memory: It achieves higher throughput by using differential pairs of signal wires to allow faster signaling without noise and interference problems. DDR2 is still double data rate just as with DDR, but the modified signaling method enables higher speeds to be achieved with more immunity to noise and cross-talk between the signals. It uses lower voltage than conventional DDR.

DDR2 memory module designs incorporate 240 pins, significantly more than conventional DDR or standard SDRAM DIMMs.

Module Standard	Chip Type	Clock Speed (MHz)	Cycles per Clock	Bus Speed (MT/s)	Bus Width (Bytes)	Transfer Rate (MBps)
PC2-3200	DDR2-400	200	2	400	8	3,200
PC2-4200	DDR2-533	266	2	533	8	4,266
PC2-5300	DDR2-667	333	2	667	8	5,333
PC2-6000	DDR2-750	375	2	750	8	6,000
PC2-6400	DDR2-800	400	2	800	8	6,400
PC2-7200	DDR2-900	450	2	900	8	7,200
PC2-8000	DDR2-1000	500	2	1000	8	8,000

DDR3 SDRAM is an improvement over its predecessor, DDR2 SDRAM, and the two are not compatible. DDR3 memory provides a reduction in power consumption of 30% compared to DDR2 modules. DDR3 DIMMS have 240 pins as DDR2 but with different key notch location.

Module Standard	Chip Type	Clock Speed (MHz)	Cycles per Clock	Bus Speed (MT/s)	Bus Width (Bytes)	Transfer Rate (MBps)
PC3-6400	DDR3-800	400	2	800	8	6400
PC3-8500	DDR3-1066	533	2	1066	8	8533
PC3-10600	DDR3-1333	667	2	1333	8	10667
PC3-12800	DDR3-1600	800	2	1600	8	12800

Typically DDR memory modules operate at different voltages, and have different number of pins.

DDR	2.5 V
DDR2	1.8 V
DDR3	1.5 V
RDRAM	2.5 V
DDR4	1.2V

Memory Module	Number of Pins
DDR	184
DDR2	240
DDR3	240
RDRAM	168
DDR4	260 / 288

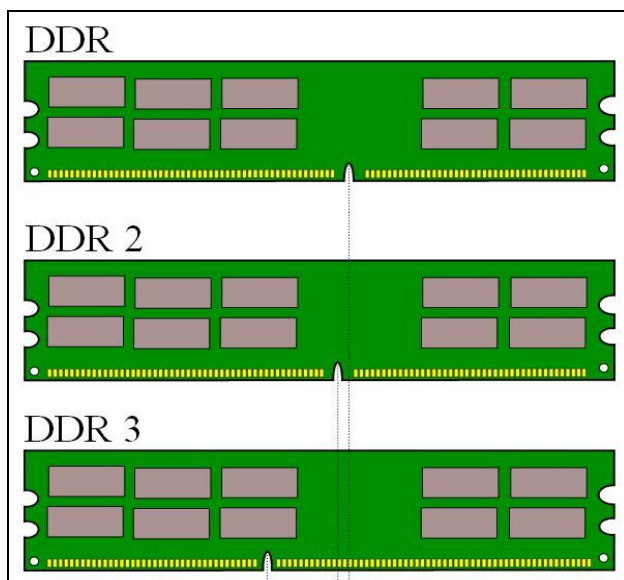

Figure 7.3 Key notch locations for DDR memories

The speed and performance issue with memory is confusing to some because memory speed is usually expressed in ns (nanoseconds) and processor speed has always been expressed in MHz (megahertz). Recently, however, some newer and faster types of memory have speeds expressed in MHz, adding to the confusion. Fortunately, you can translate one to the other.

A nanosecond is defined as one billionth of a second.

Megahertz (MHz) which is millions of cycles per second, and gigahertz (GHz) which is billions of cycles per second.

To convert access time in nanoseconds to MHz, use the following formula:

$$1 / \text{nanoseconds} \times 1000 = \text{MHz}$$

Likewise, to convert from MHz to nanoseconds, use the following inverse formula:

$$1 / \text{MHz} \times 1000 = \text{nanoseconds}$$

DDR3L: is the DDR3 Low Voltage Specification its standard voltage is 1.3V

DDR3U: is the DDR3 Low Voltage Specification its standard voltage is 1.2V

DDR4 SDRAM

Module Standard	Chip Type	Clock Speed (MHz)	Bus Speed (MT/s)	Transfer Rate (MBps)
PC4-17000	DDR4-2133	2133	2133	17000
PC4-19200	DDR4-2400	2400	2400	19200

RDRAM

Rambus DRAM (RDRAM) on the other hand, are narrow-channel devices. They transfer data only 16 bits (2 bytes) at a time (plus 2 optional parity bits), but at much faster speeds. This is a shift away from a more parallel to a more serial design and is similar to what is happening with other evolving buses in the PC.

RDRAM DIMMS have 168 pins, RDRAM runs on only 2.5 volts.

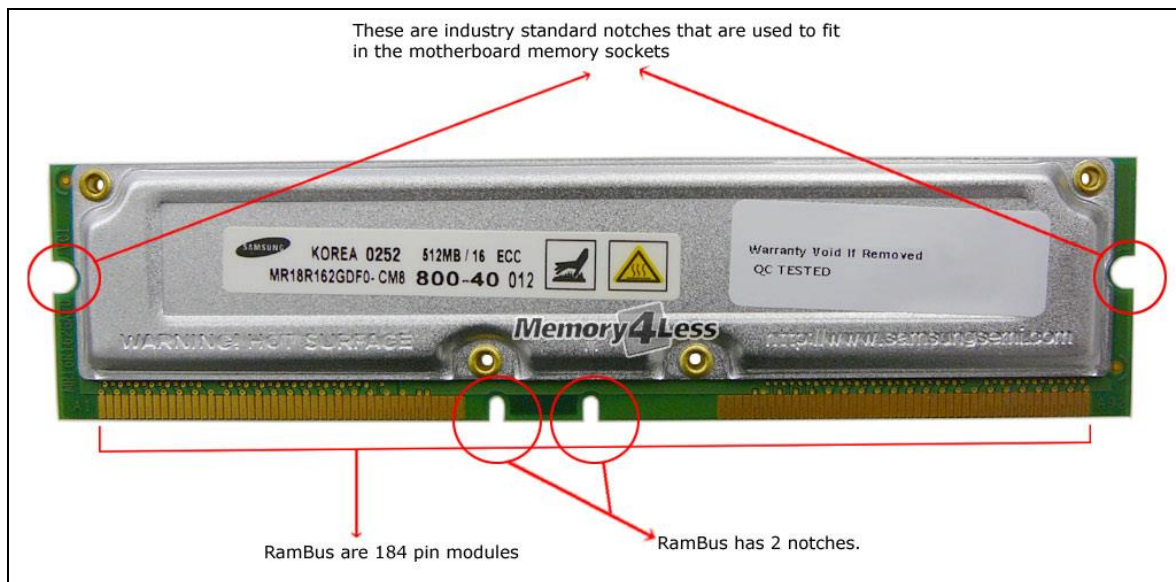

Figure 7.4 RDRAM key Notches

The design of many common Rambus memory controllers dictated that memory sticks be installed in sets of two. Any remaining open memory slots must be filled with CRIMMs (Continuity Rambus Inline Memory Module). These sticks provide no extra memory, and only served to propagate the signal to termination resistors on the motherboard instead of providing a dead end where signals would reflect.



Figure 7.5 Rambus DRAM

Module Standard	Chip Type	Clock Speed (MHz)	Cycles per Clock	Bus Speed (MT/s)	Bus Width (Bytes)	Transfer Rate (MBps)
RIMM1200	PC600	300	2	600	2	1,200
RIMM1400	PC700	350	2	700	2	1,400
RIMM1600	PC800	400	2	800	2	1,600
RIMM2100	PC1066	533	2	1,066	2	2,133
RIMM2400	PC1200	600	2	1,200	2	2,400
RIMM3200	PC800	400	2	800	4	3,200
RIMM4200	PC1066	533	2	1,066	4	4,266
RIMM4800	PC1200	600	2	1,200	4	4,800

CAS Latency (Column Address Strobe)

Latency is the time the memory controller must wait between requesting a data and the actual delivery of them. It is also known as CAS (Column Address Strobe) Latency or simply CL. This number is expressed in terms of clock cycles.

For example, a memory with CL3 means that the memory controller must wait three clock cycles until data is delivered after a request is made. With a memory with CL5 the memory controller will have to wait more: five clock cycles. So you always should look for the memory modules with the lowest latency possible.

Technology	Typical Latency	Other Common Latencies Available
DDR	3	2, 2.5
DDR2	5	3, 4
DDR3	7	6, 8, 9

Cache Memory

A **CPU cache** is a cache used by the central processing unit of a computer to reduce the average time to access memory. The cache is a smaller, faster memory which stores copies of the data from the most frequently used main memory locations. As long as most memory accesses are cached memory locations, the average latency of memory accesses will be closer to the cache latency than to the latency of main memory.

To minimize the processor being forced to read data from the slow main memory, two or three stages of cache usually exist in a modern system, called Level 1 (L1), Level 2 (L2), and Level 3 (L3). The L1 cache is also called integral or internal cache because it has always been built directly into the processor as part of the processor die (the raw chip). Because of this, L1 cache always runs at the full speed of the processor core and is the fastest cache in any system. All 486 and higher processors incorporate integral L1 cache, making them significantly faster than their predecessors. L2 cache was originally called external cache because it was external to the processor chip when it first appeared. Originally, this meant it was installed on the motherboard, as was the case with all 386, 486, and Pentium systems. In those systems, the L2 cache runs at motherboard and CPU bus speed because it is installed on the motherboard and is connected to the CPU bus. You typically find the L2 cache directly next to the processor socket in Pentium and earlier systems.

L3 cache has been present in high-end workstation and server processors such as the Xeon and Itanium families since 2001. The first desktop PC processor with L3 cache was the Pentium 4 Extreme Edition, a high-end chip introduced in late 2003 with 2MB of on-die L3 cache.

Read Only Memory (ROM)

Read-only memory, or ROM, is a type of memory that can permanently or semi permanently store data. It is called read-only because it is either impossible or difficult to write to. ROM also is often referred to as nonvolatile memory because any data stored in ROM remains there, even if the power is turned off.

ROM chip contains the following programs

- BIOS
- POST Program
- BootStrap Loader

BIOS is a term that stands for basic input/output system, which consists of low-level software that controls the system hardware and acts as an interface between the operating system and the hardware. Most people know the term BIOS by another name device drivers, or just drivers. In other words, the BIOS is drivers, meaning all of them. BIOS is essentially the link between hardware and software in a system.

POST is a term that stands for Power On Self Test it checks out the system every time system boots. If there is a problem in any of the components of the system POST Conveys information about the problem in two ways one is Beep codes and Second through text messages. (beep codes are available in beep code sheet)

BootStrap Loader program was designed to initiate the loading of an OS from the Hard disc or CD/DVD disc or any other device.

ROM Chip Types

The four main types of ROM chips that have been used in PCs are as follows:

- ROM. Read-only memory
- PROM. Programmable ROM
- EPROM. Erasable PROM
- EEPROM. Electrically erasable PROM, also sometimes called a flash ROM

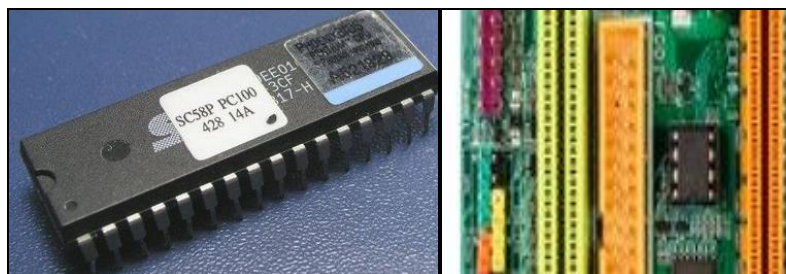

Figure 7.6 ROM

Upgrade⁵ BIOS

Update the BIOS to fix bugs, add compatibility with new devices, improve caching functions, and make several other hardware tweaks that can speed up your boot time and fix annoying issues. These updates are available at the motherboard manufacturer's site. But if you make a mistake in the update process, your PC will be unbootable.

Step 1: identify the BIOS version in BIOS setting or type **msinfo32** in windows Run window, identify the motherboard model and BIOS model.

Step 2: Download Updated version of BIOS from manufacturer's website. While downloading, be sure about model and type of motherboard. It will be an .exe file

Step 3: close all of the applications

Step 4: Run the Installer .exe file.

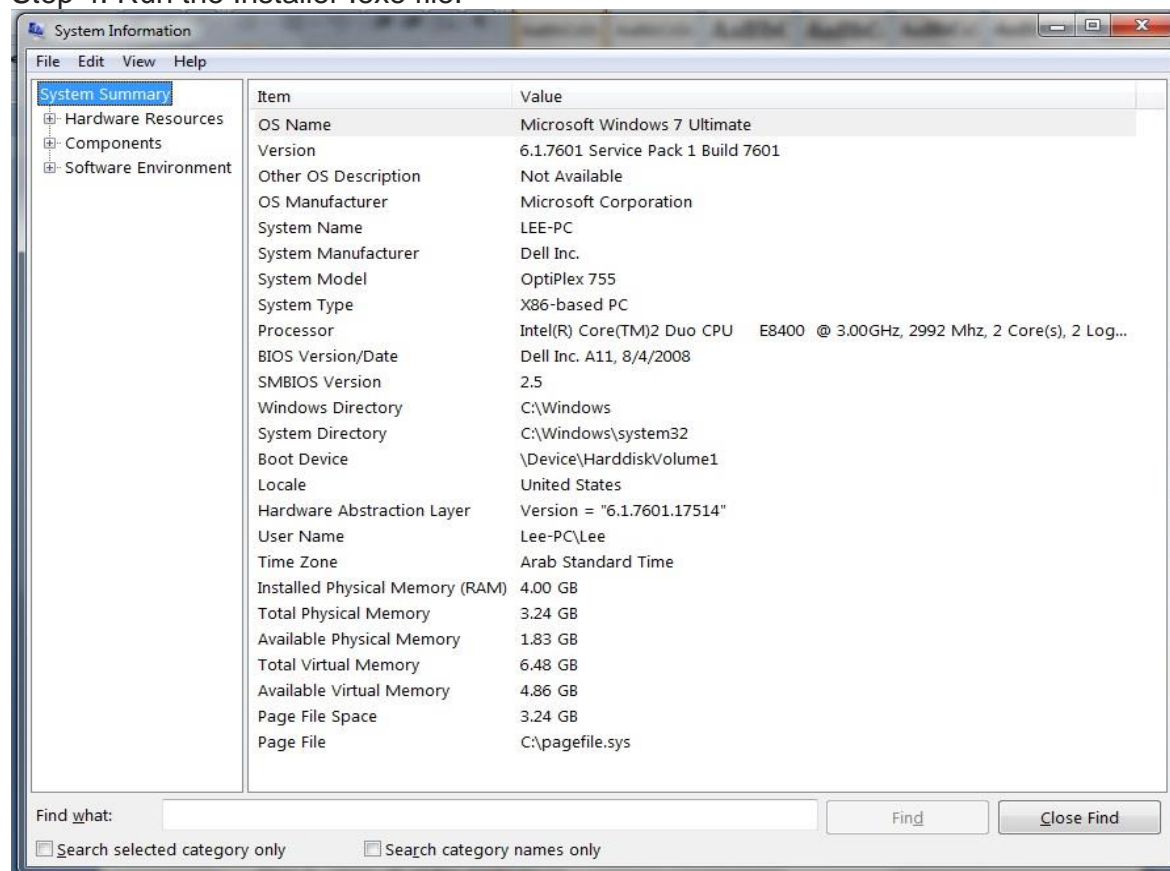

Figure 7.7 msinfo32

Note: Follow the instructions by manufacturer during BIOS update.

Primary Memories for Laptop/Notebook Computer

Laptop memories are similar in capacity and other specifications as Desktop memory. Difference is in form-factor. It is 200 pin Small Outline DIMM.

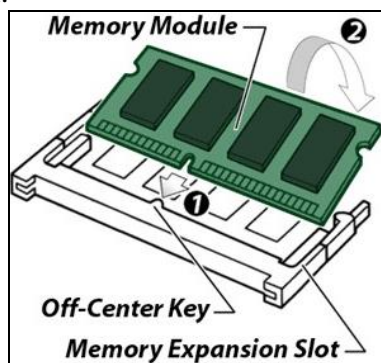

Figure 7.8 SO-DIMM DDR2 Memory

Safety

- ⊛ Turn-off power supply
- ⊛ Install the memory such that memory module is completely inserted in to DIMM slot.
- ⊛ If more than one module of memory is their make sure both are of same speed.
- ⊛ Do not apply physical force while inserting memory module in to DIMM

Terminologies

1. Memory ذاكرة
2. Main memory الذاكرة الرئيسية
3. Secondary memory الذاكرة الثانوية
4. Data path مسار البيانات
5. Upgrade ترقية

Chapter 7

Operating System Setup and Installations.

Linux™



Microsoft®
Windows™ xp



ubuntu

Windows® 7



Objectives

- Understand Bootable Media
- Setup and Install Single Operating System, Win XP, Win 7, Ubuntu
- Dual Operating Systems Setup and Installation.
- Device Drivers Installation and Configuration.

Windows 7 Setup and Installation



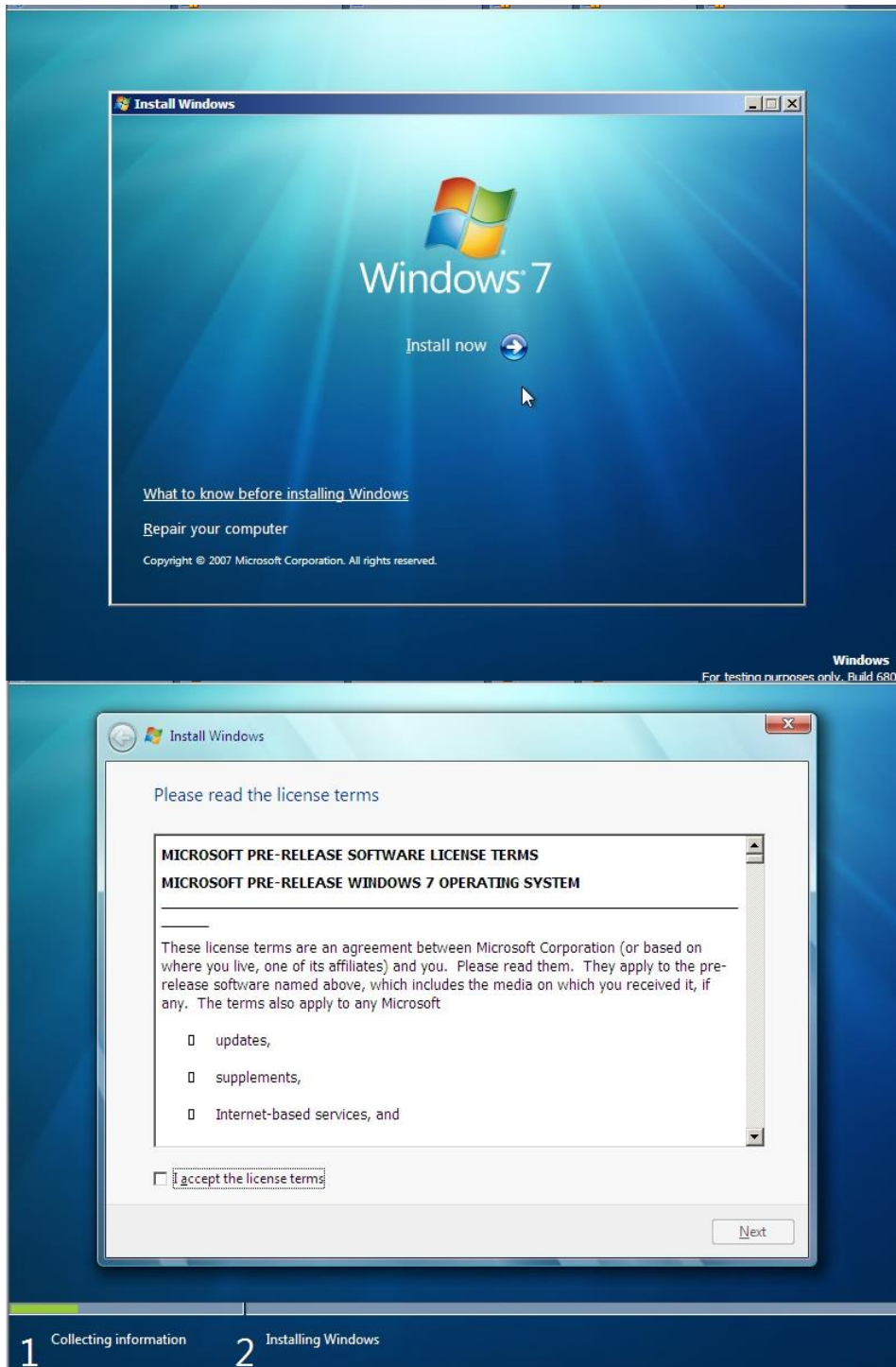

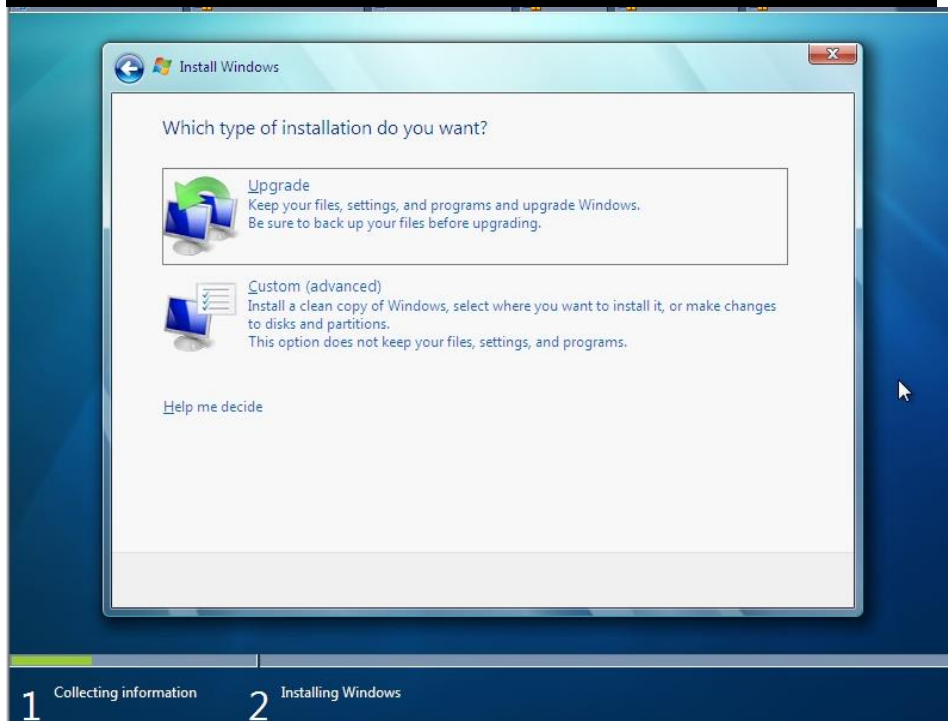
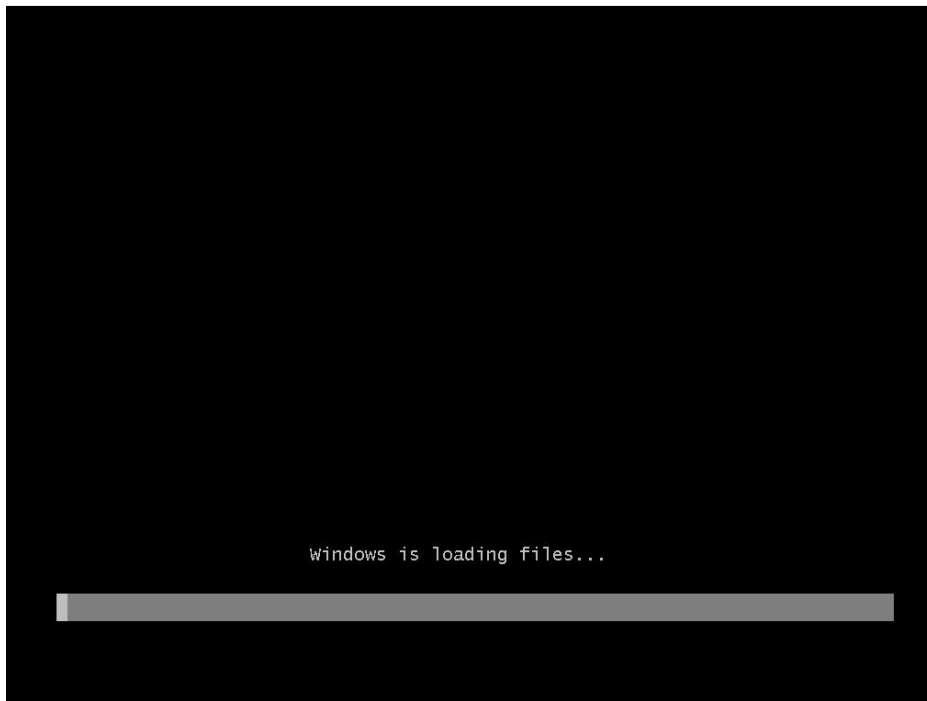

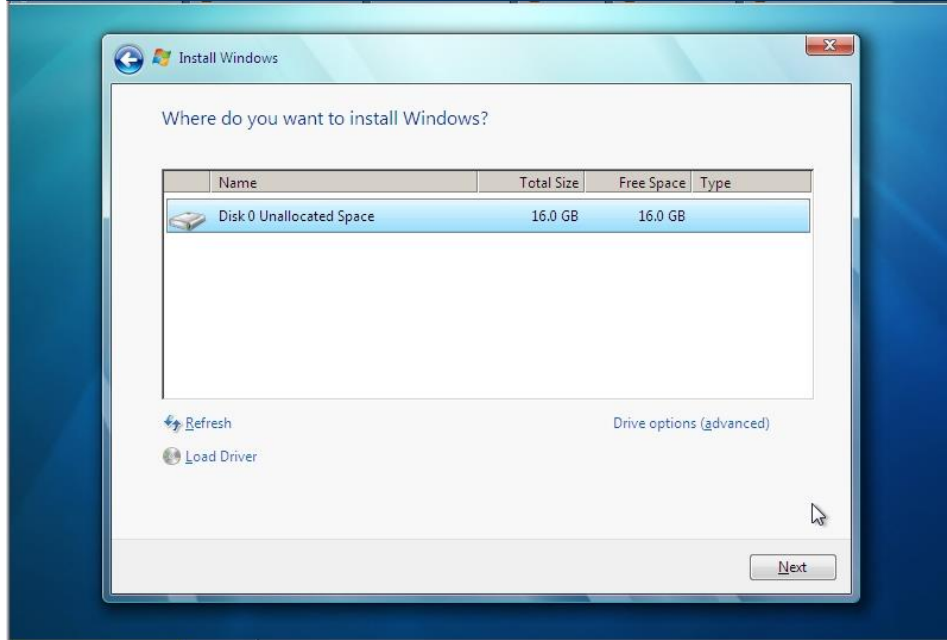
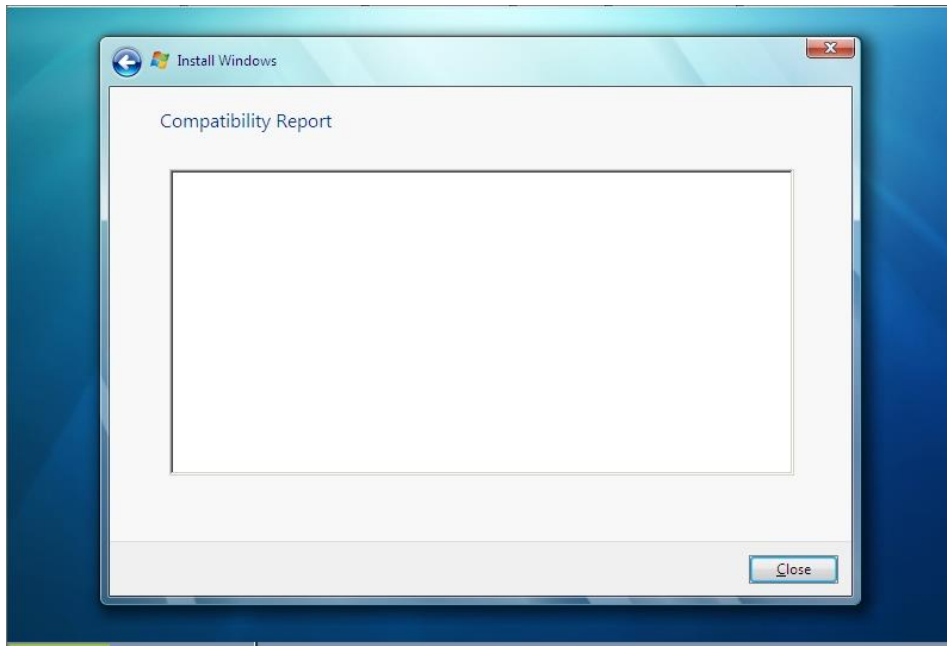

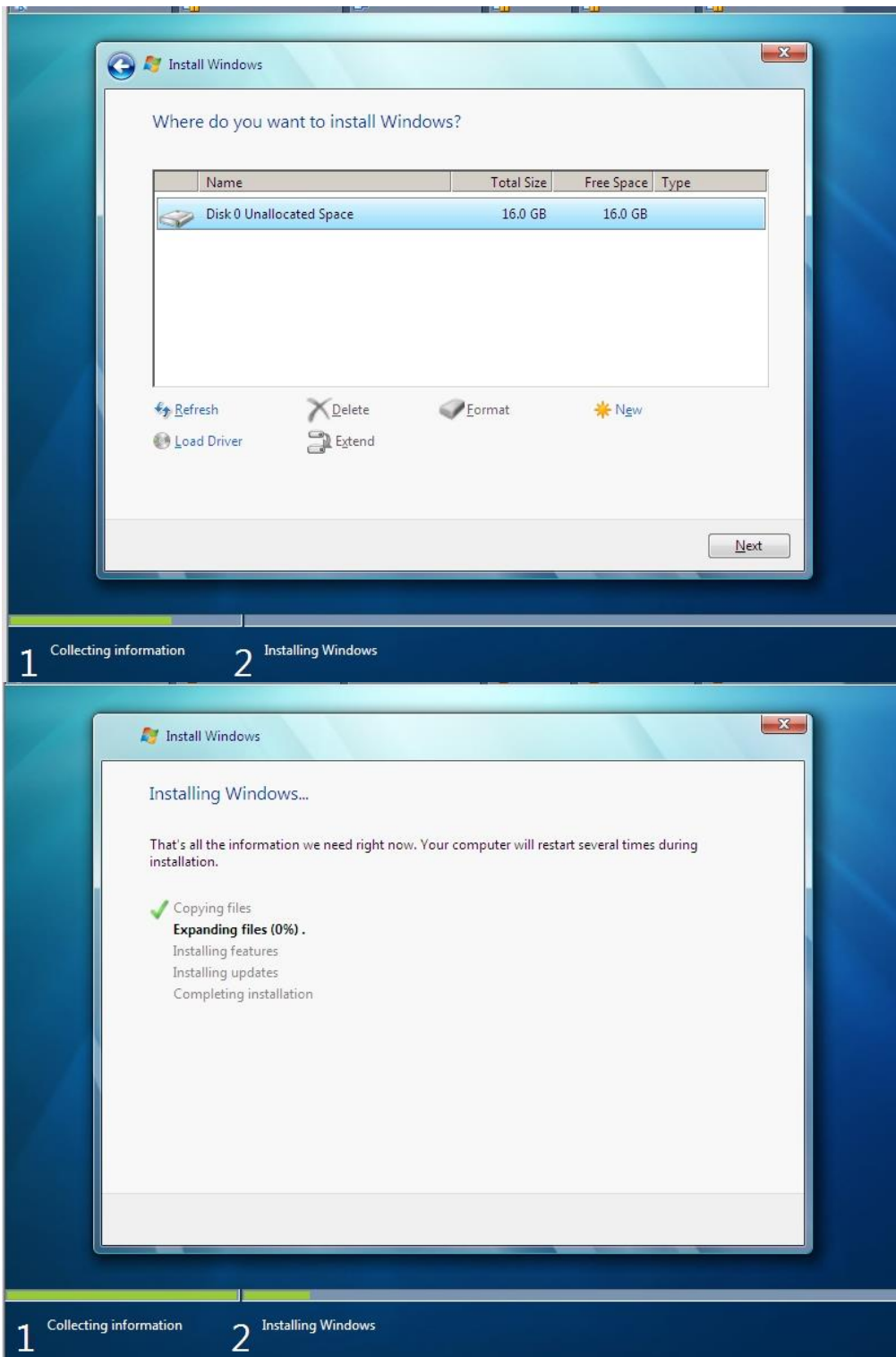

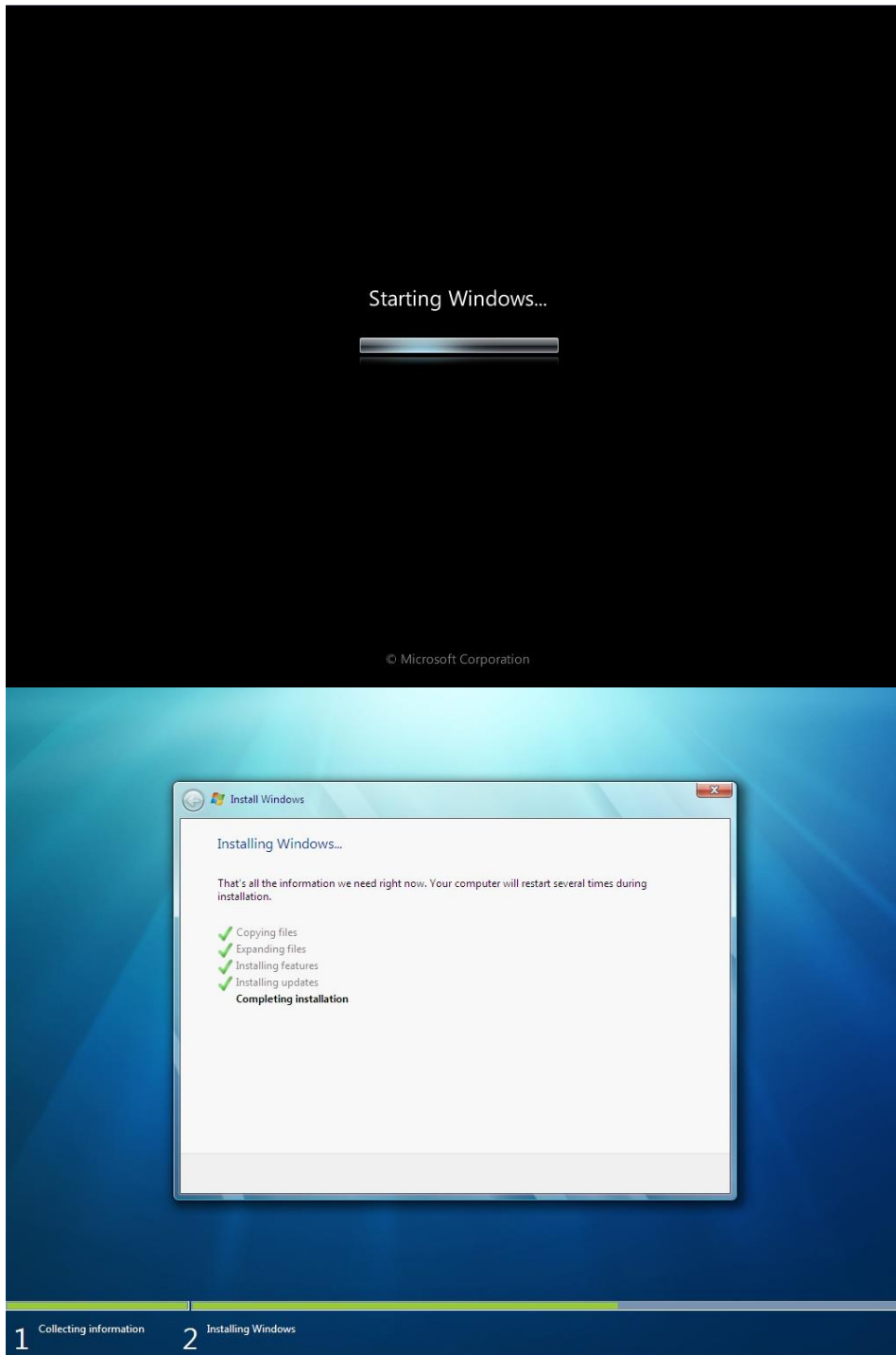

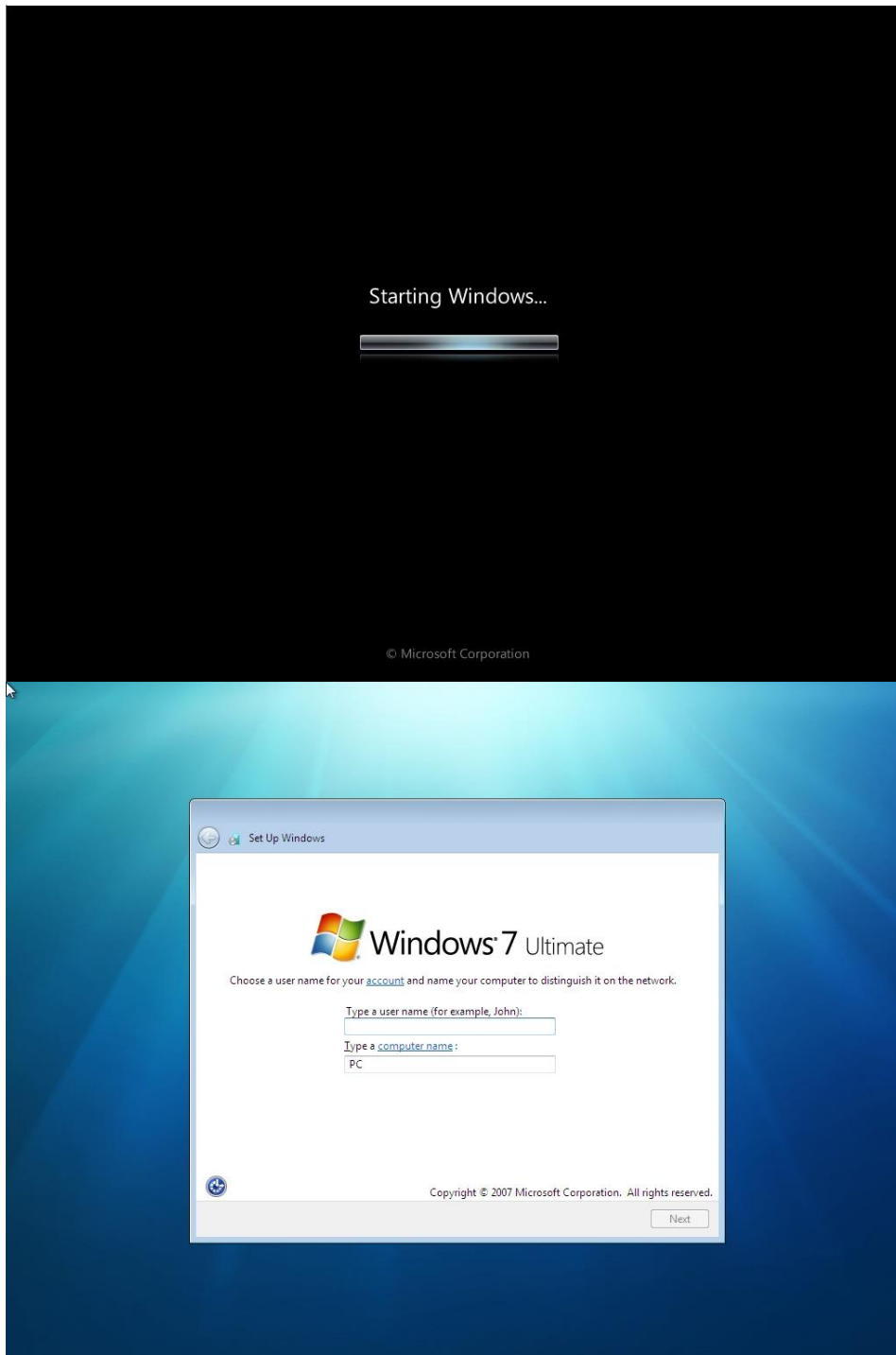

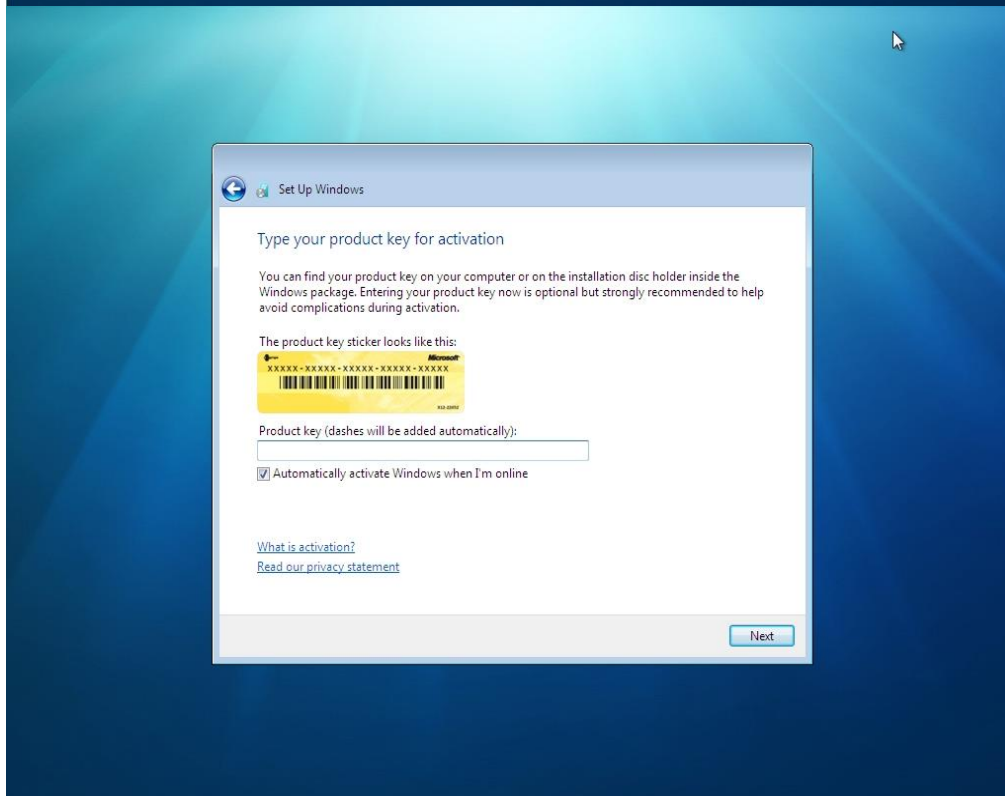
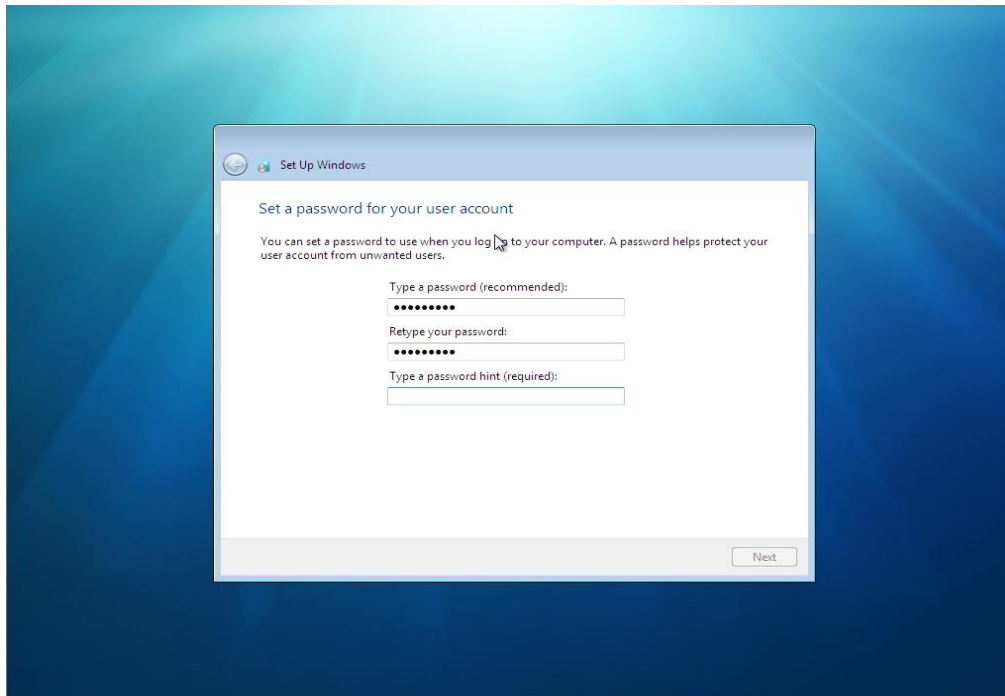

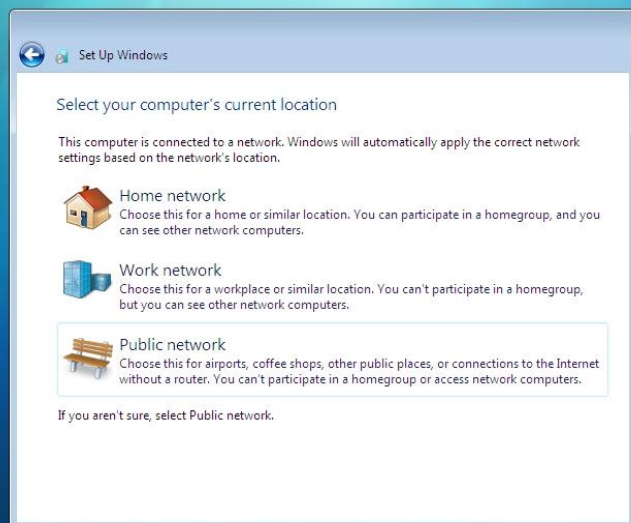
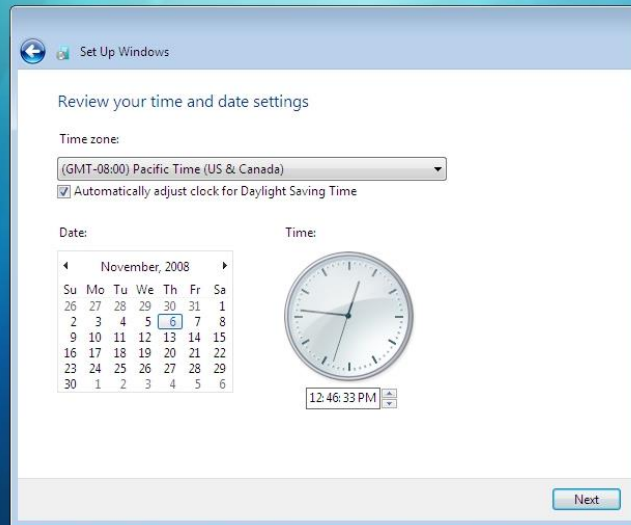

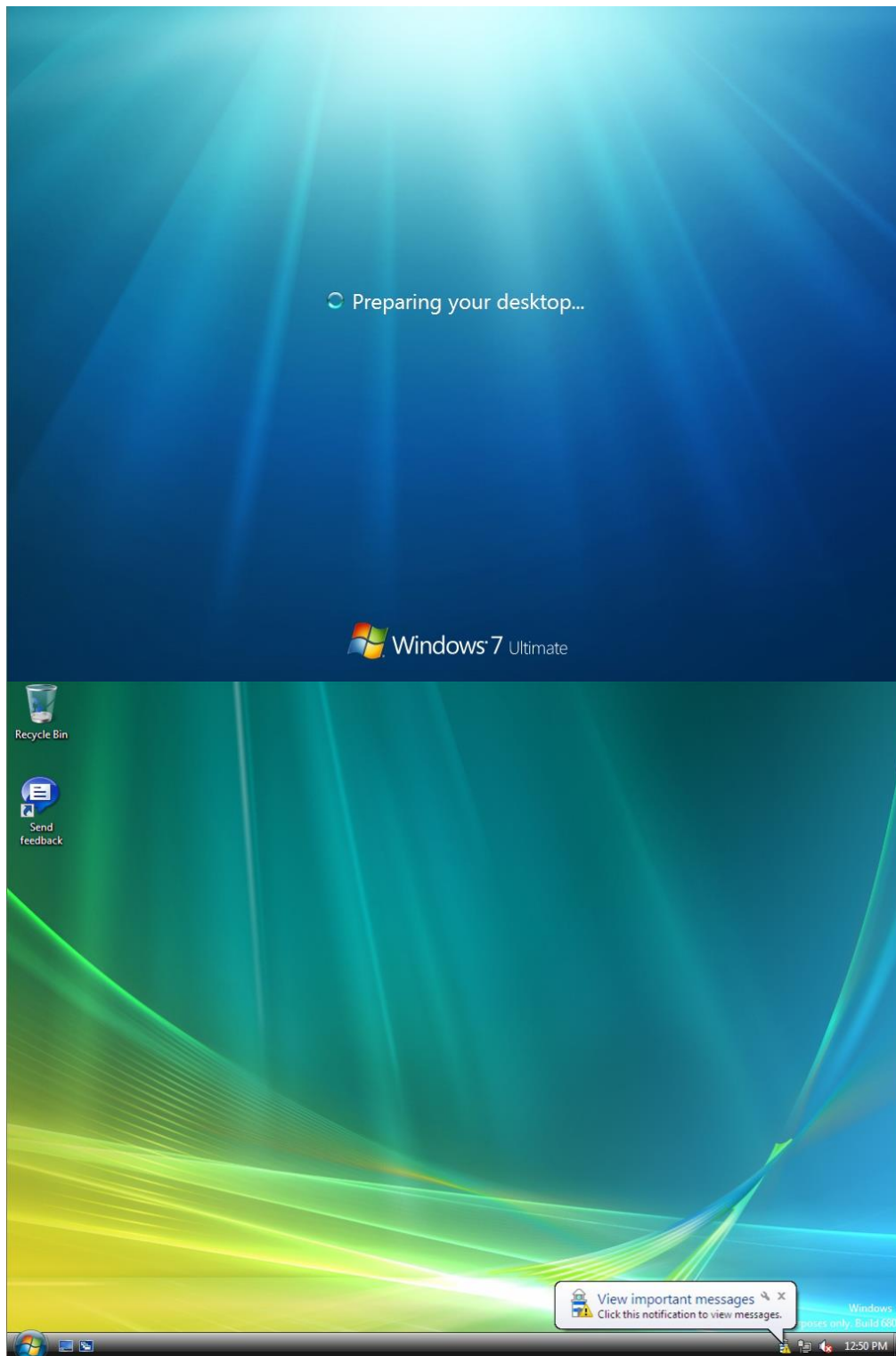

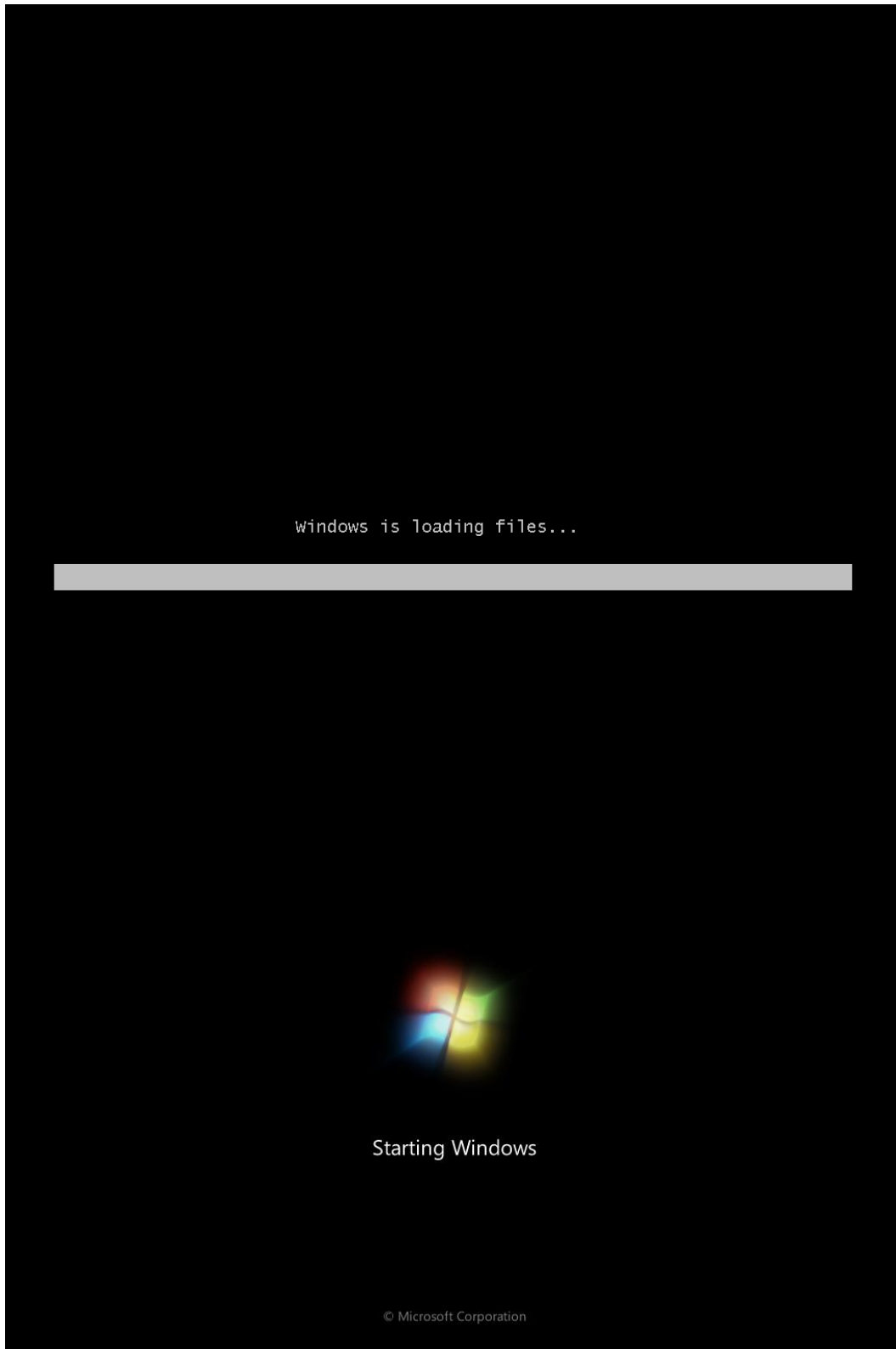

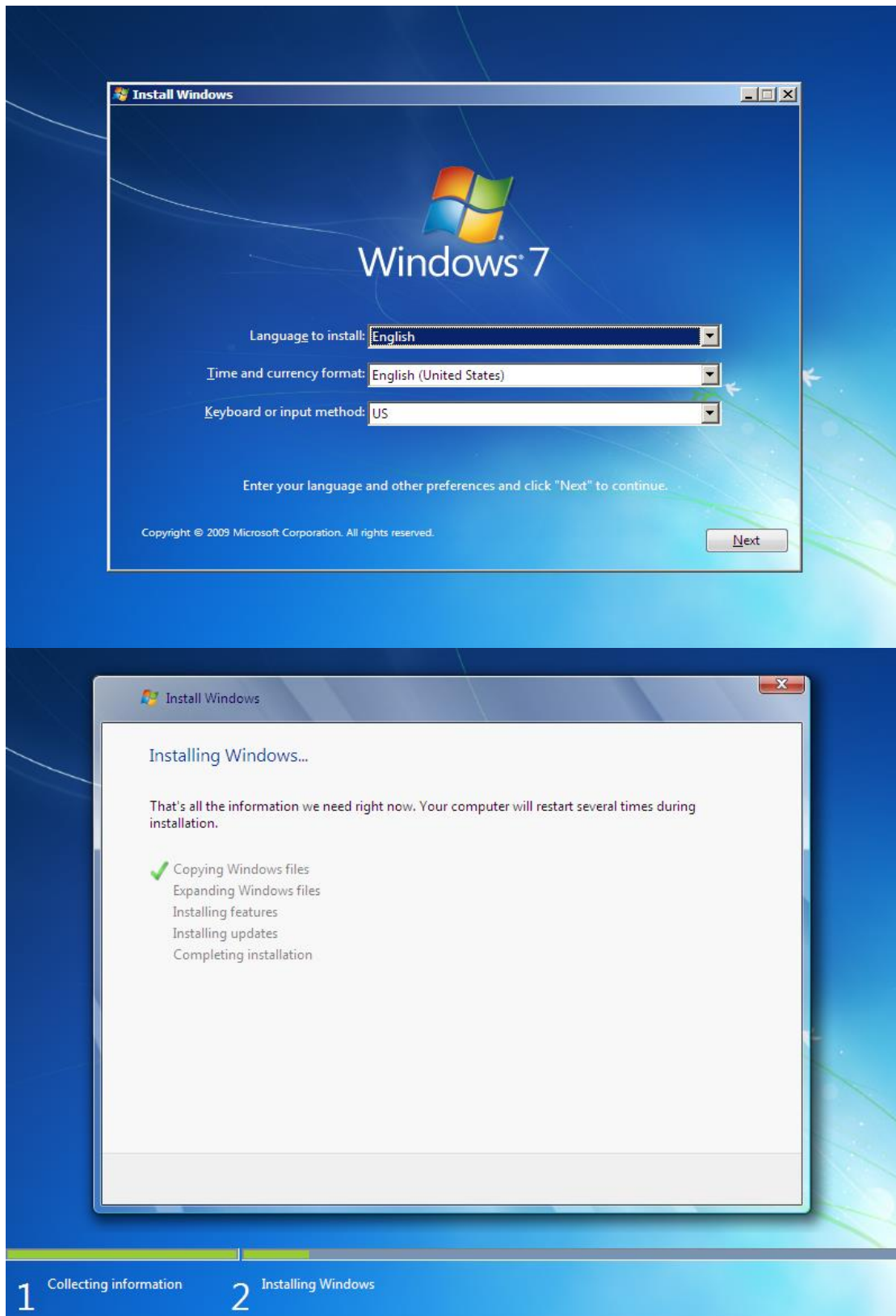

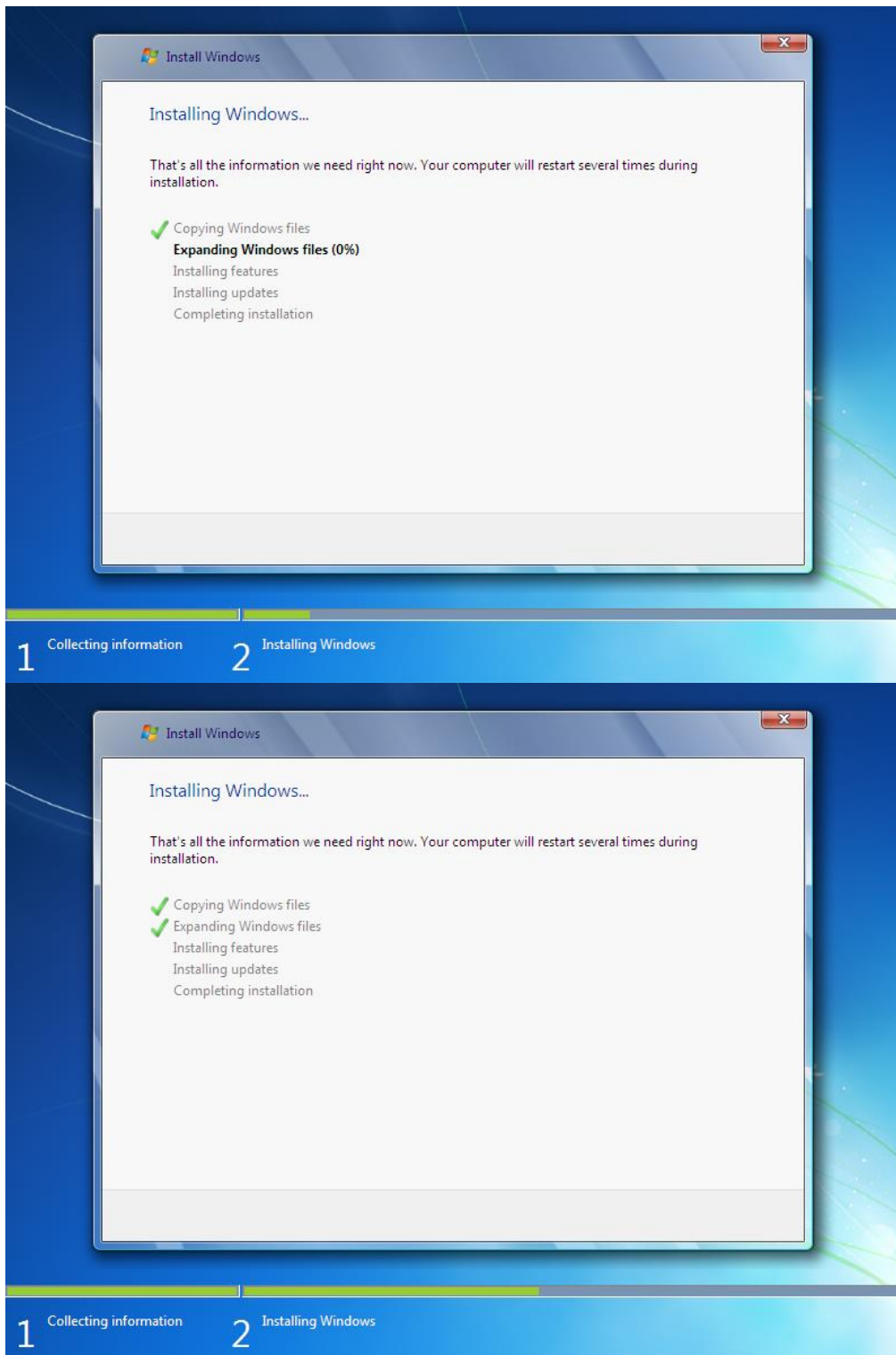

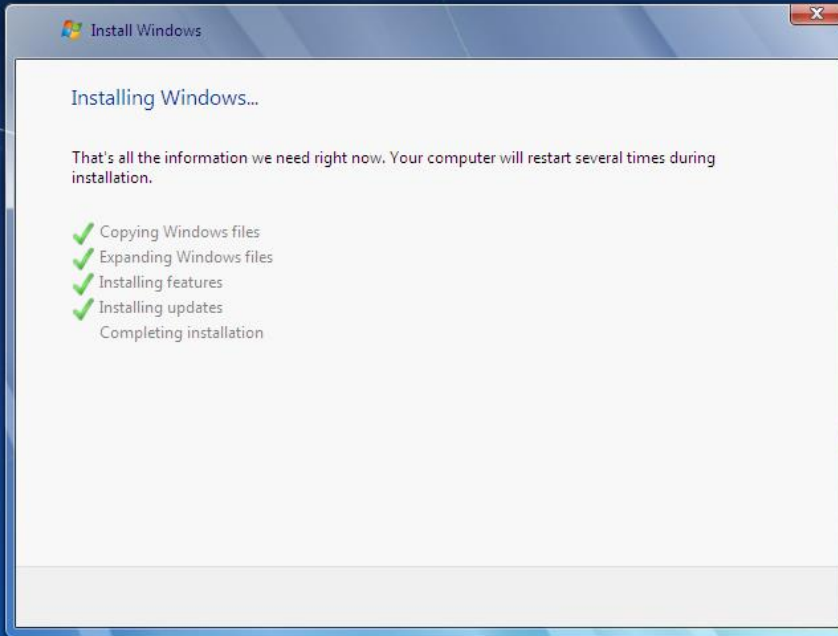
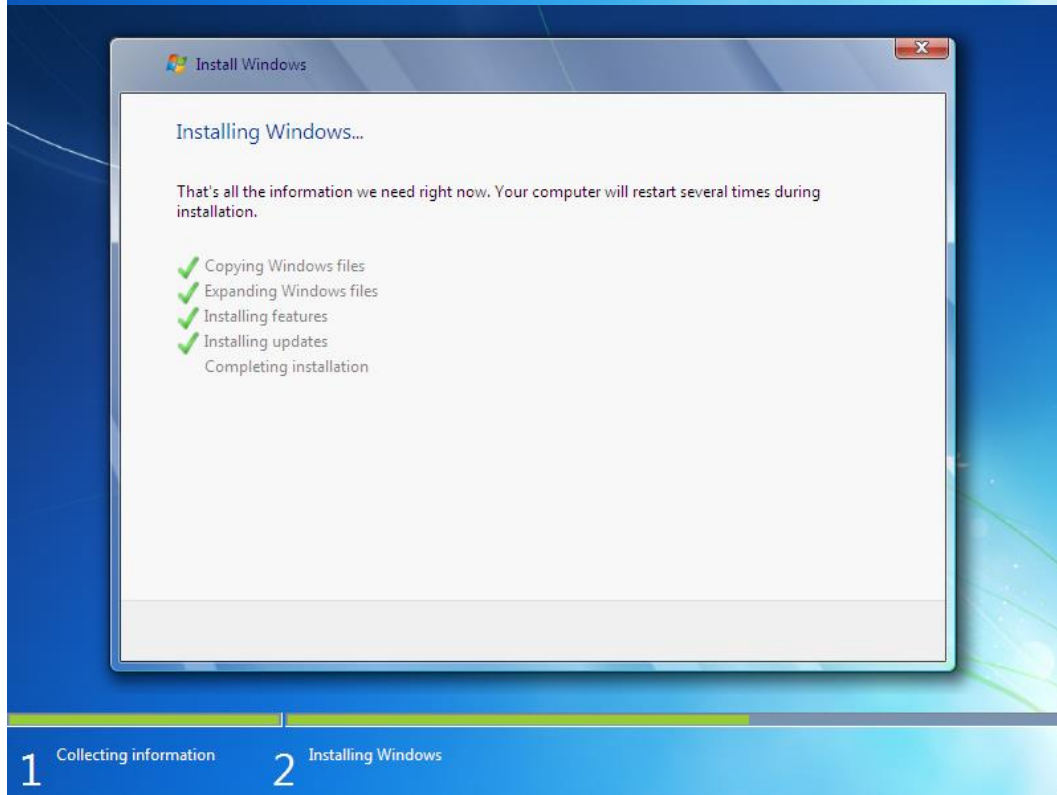
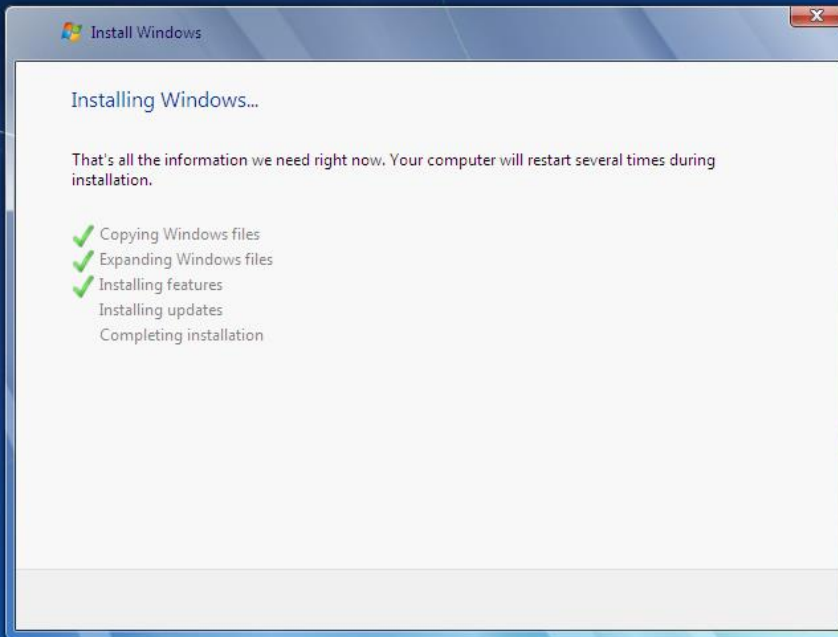
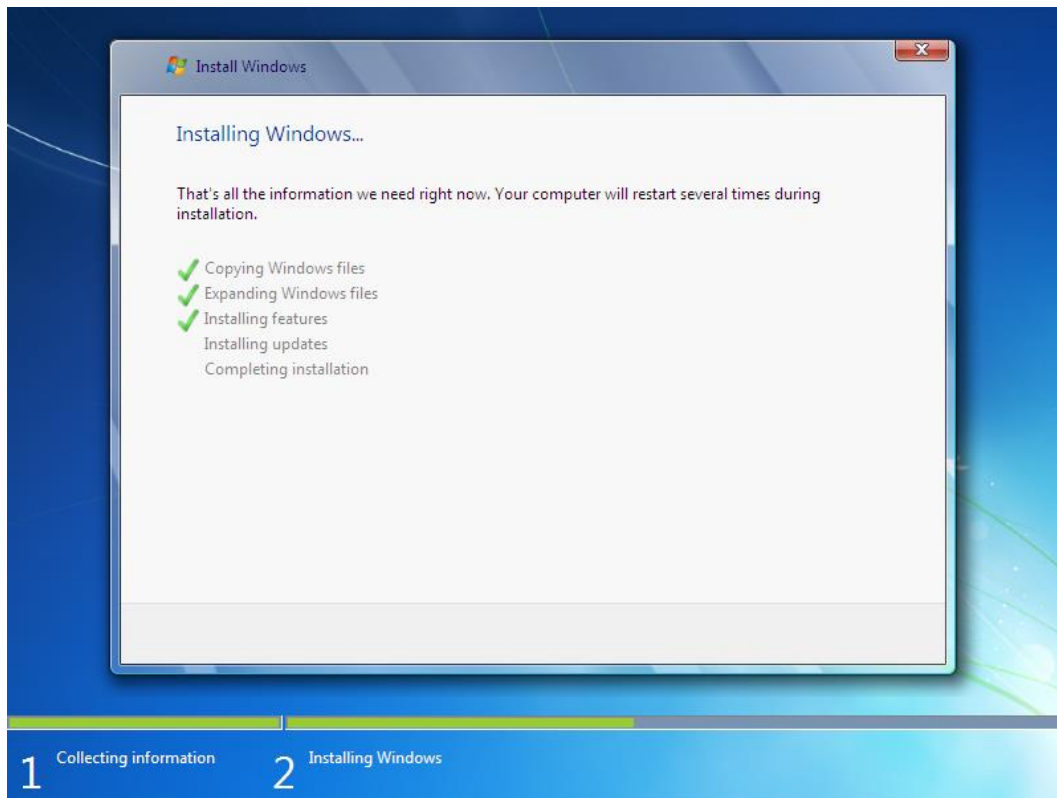

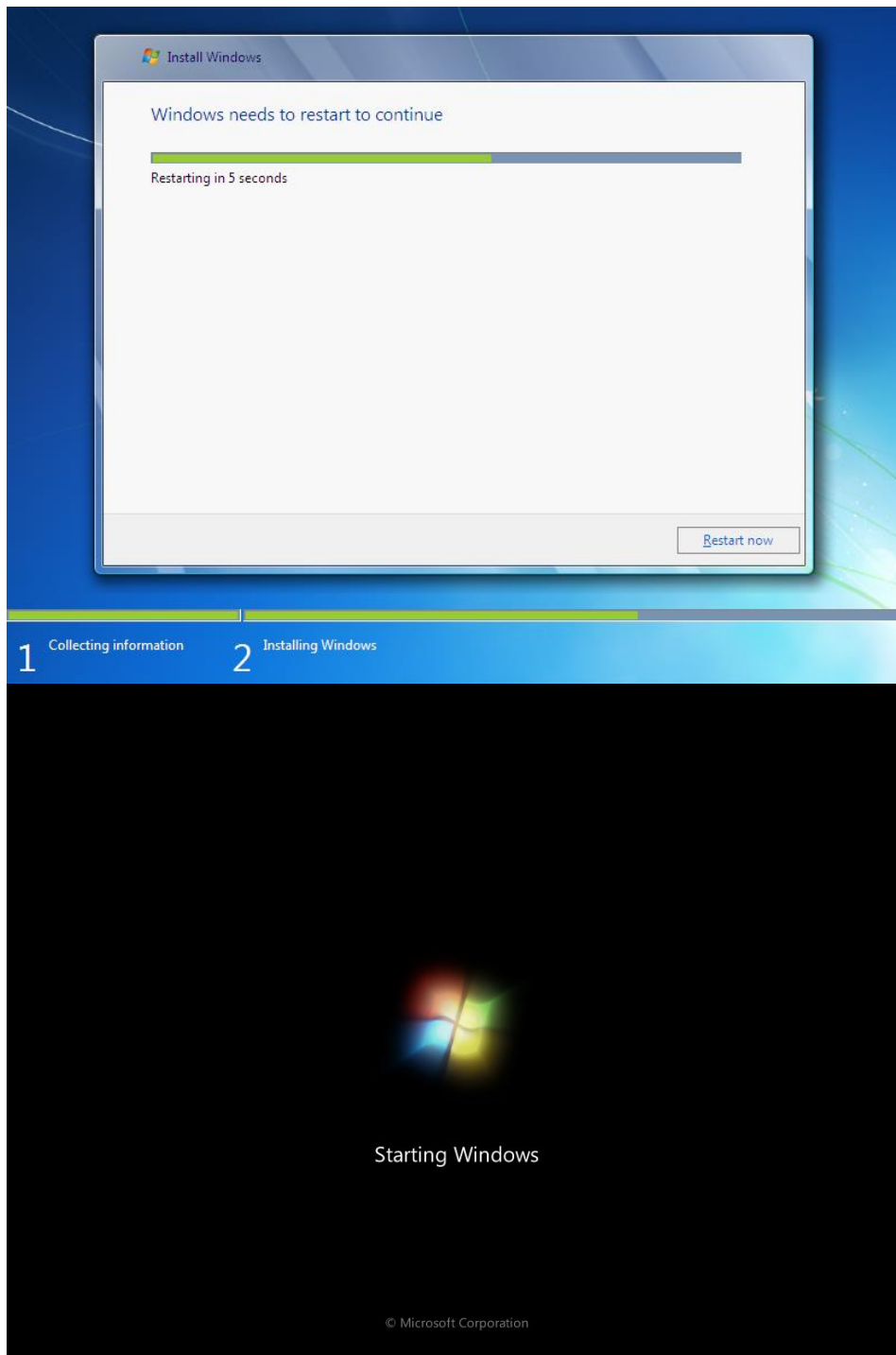

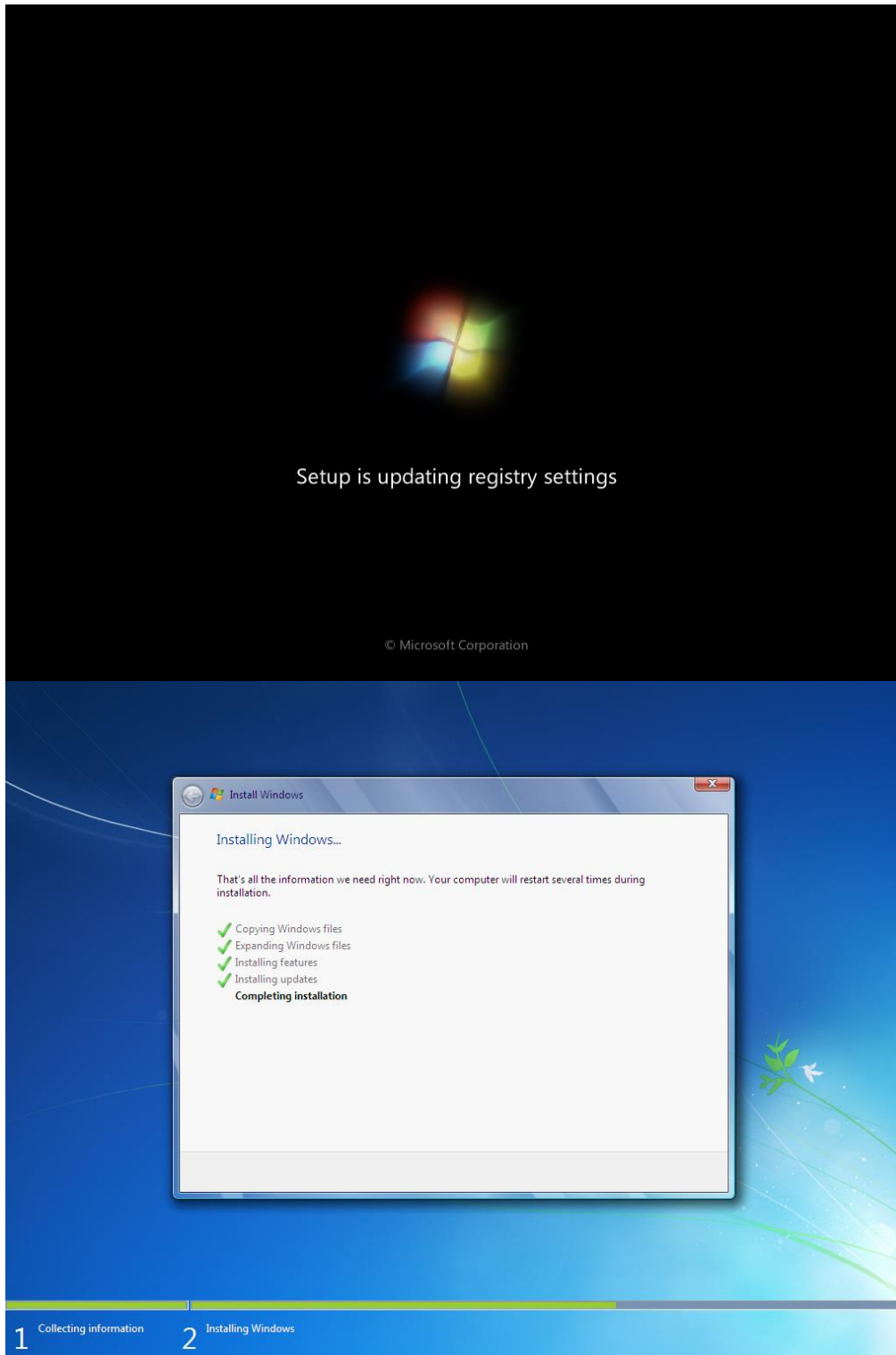

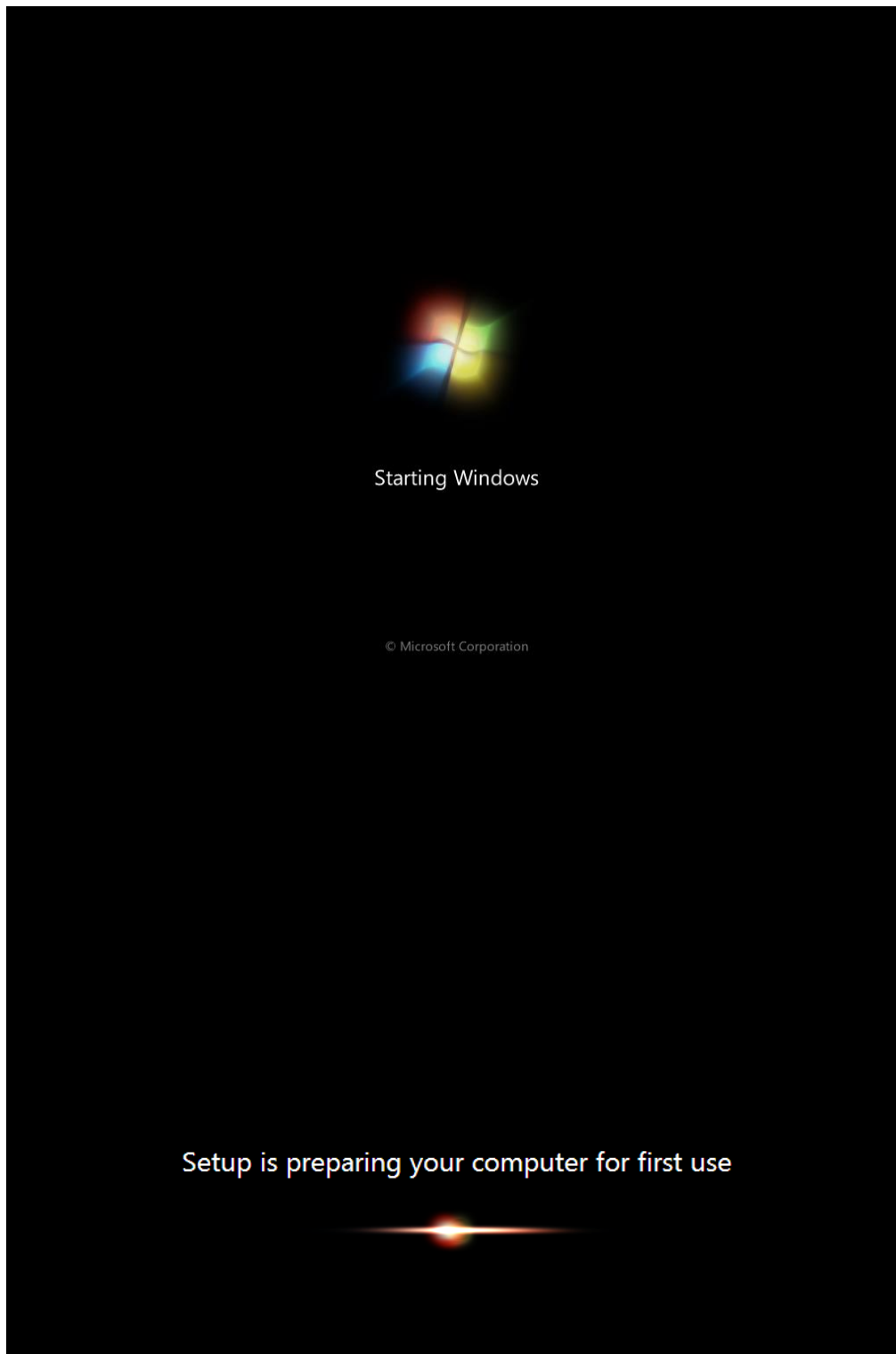

Setup is checking video performance

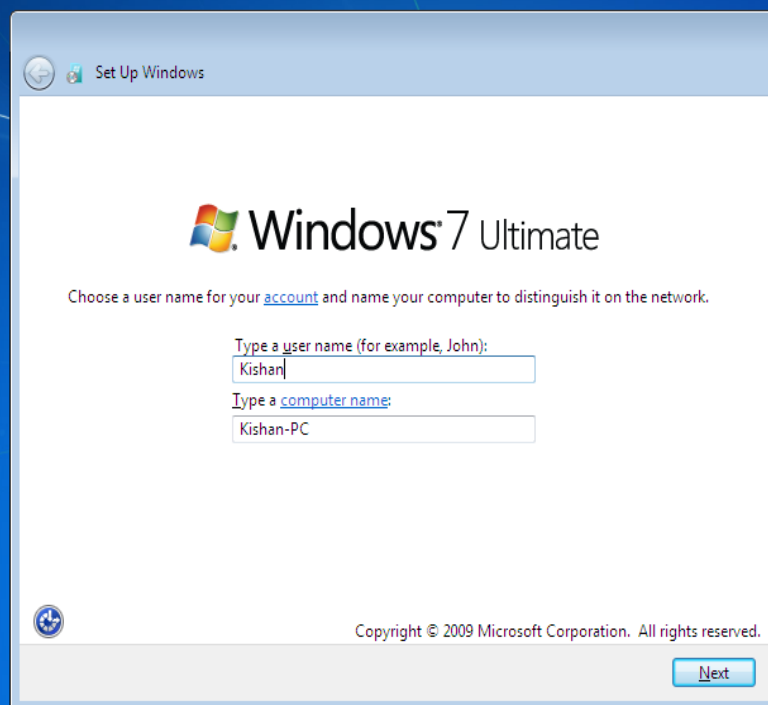

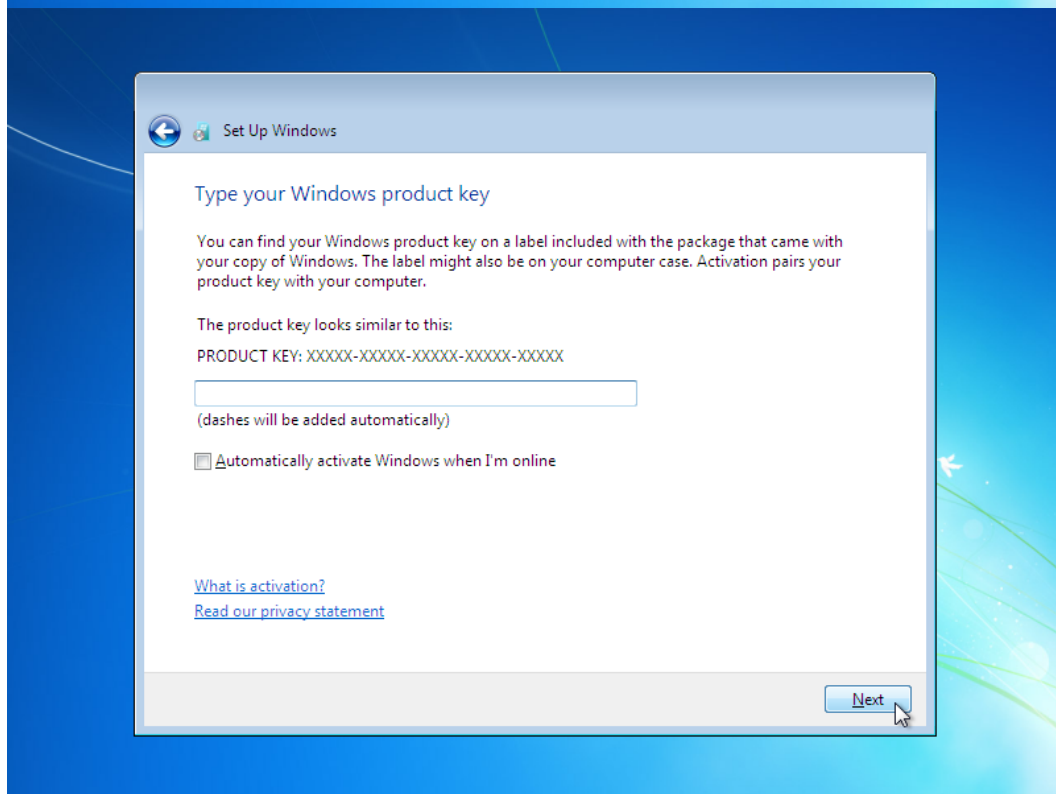
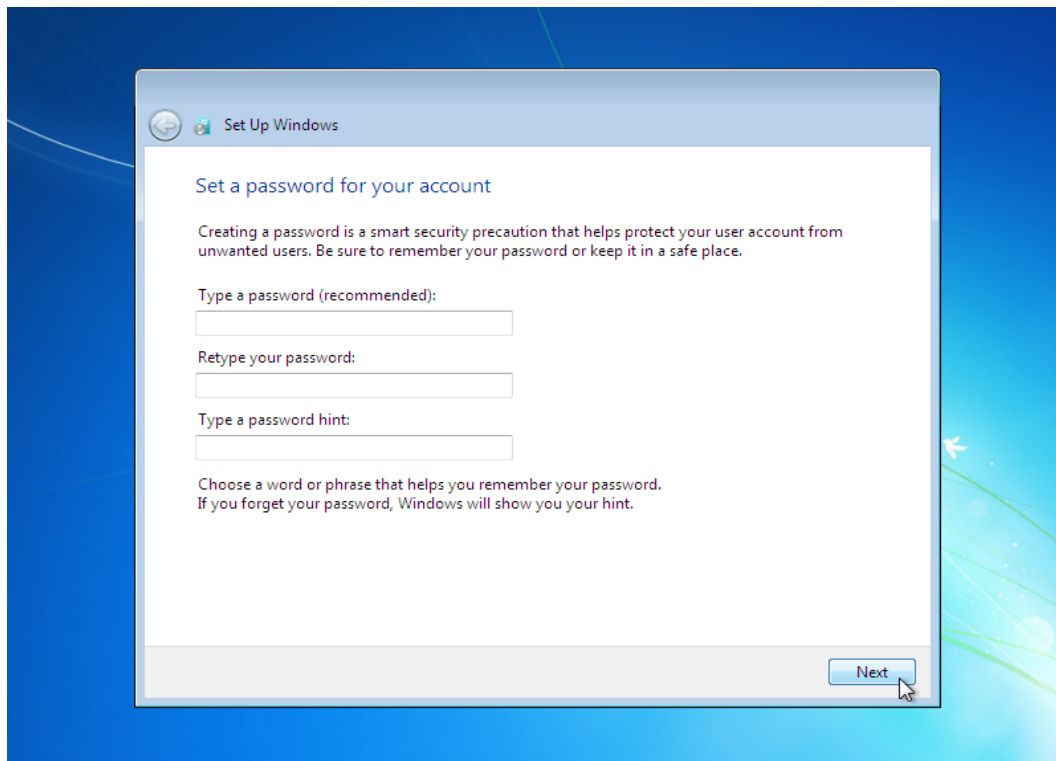

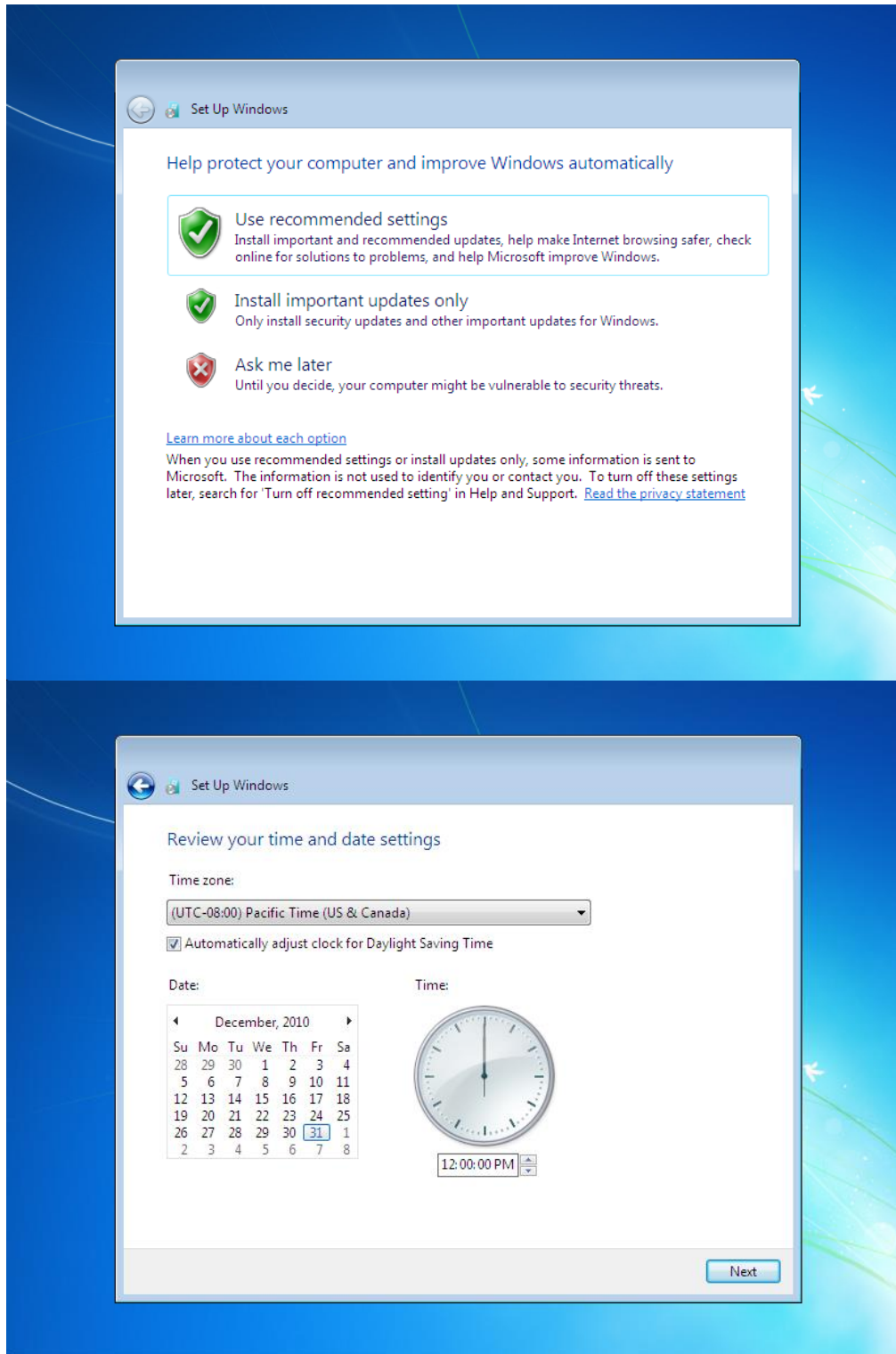

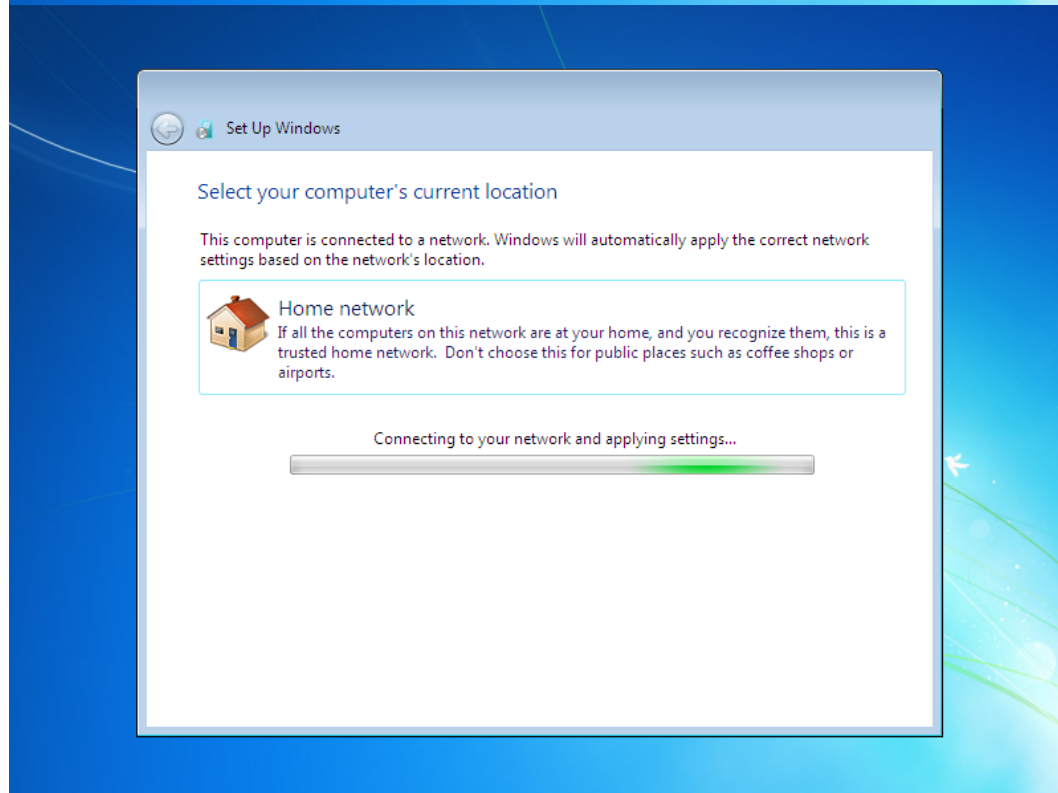
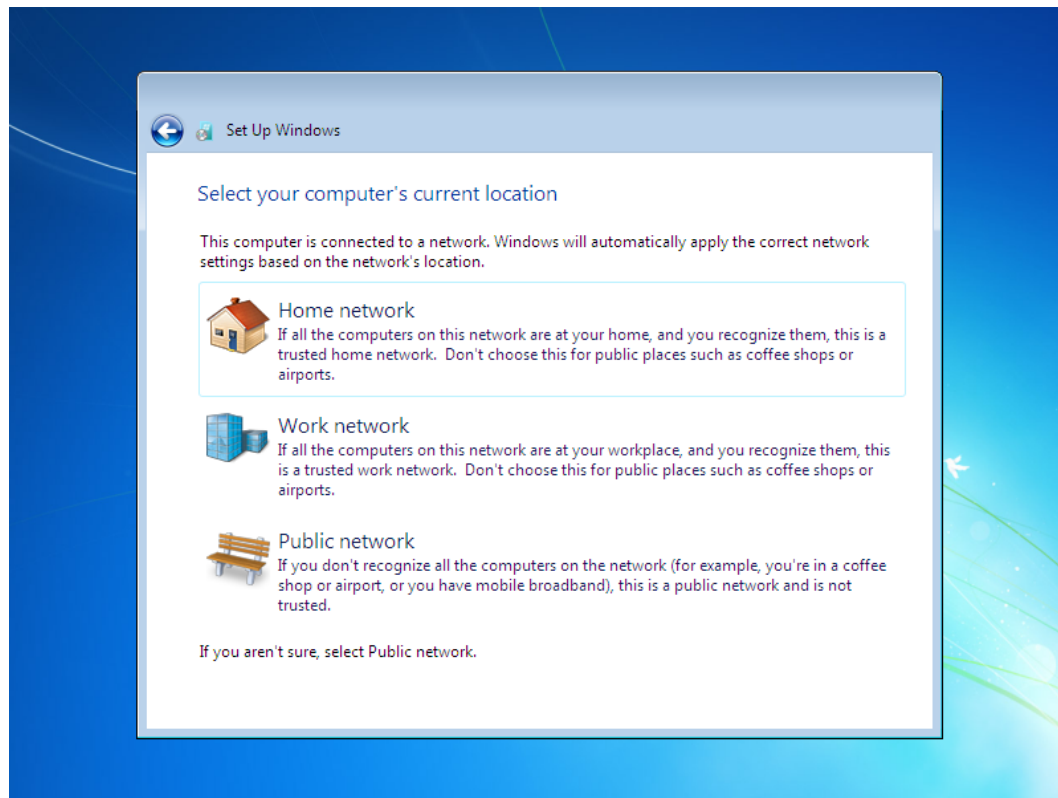

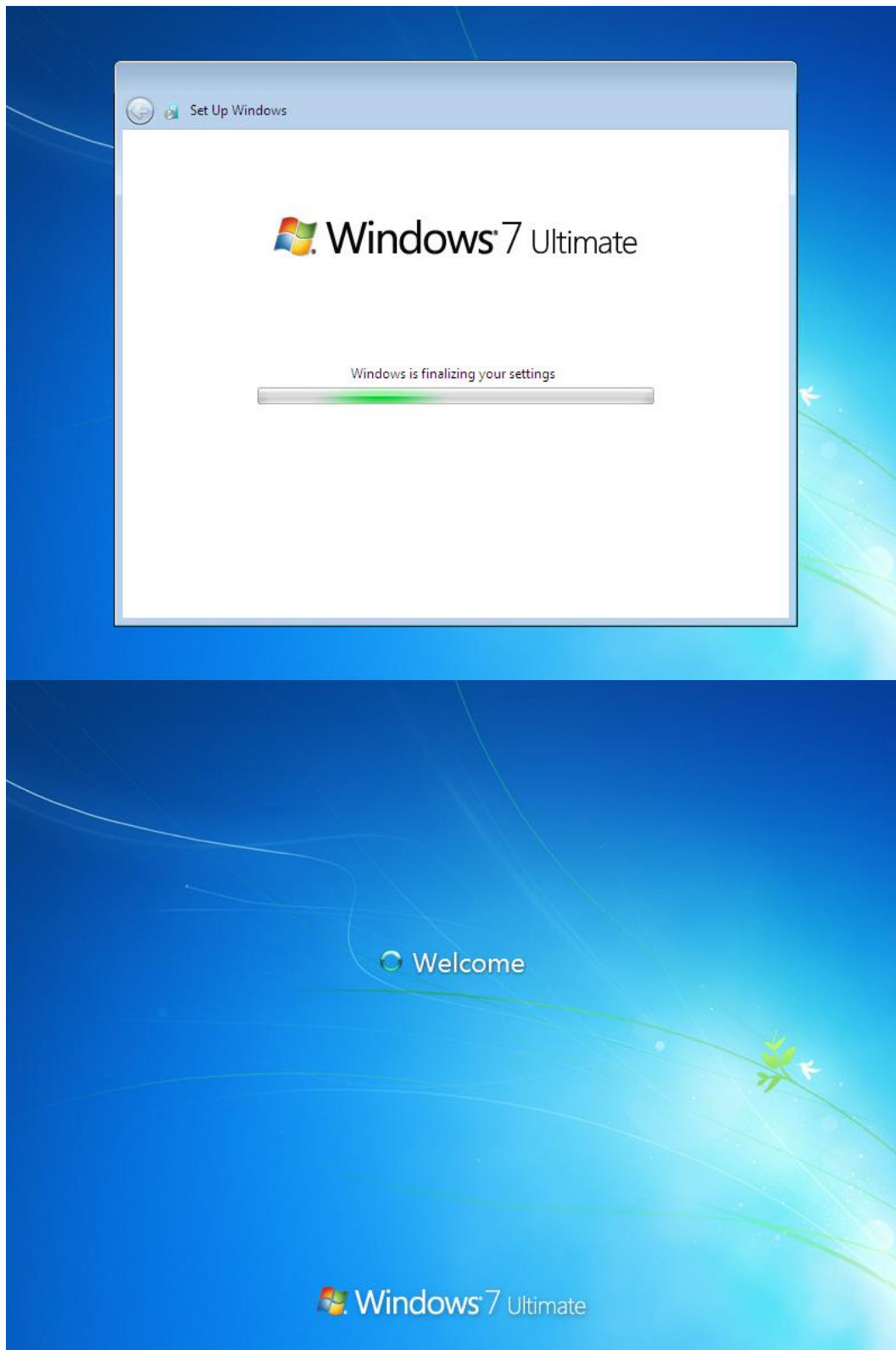

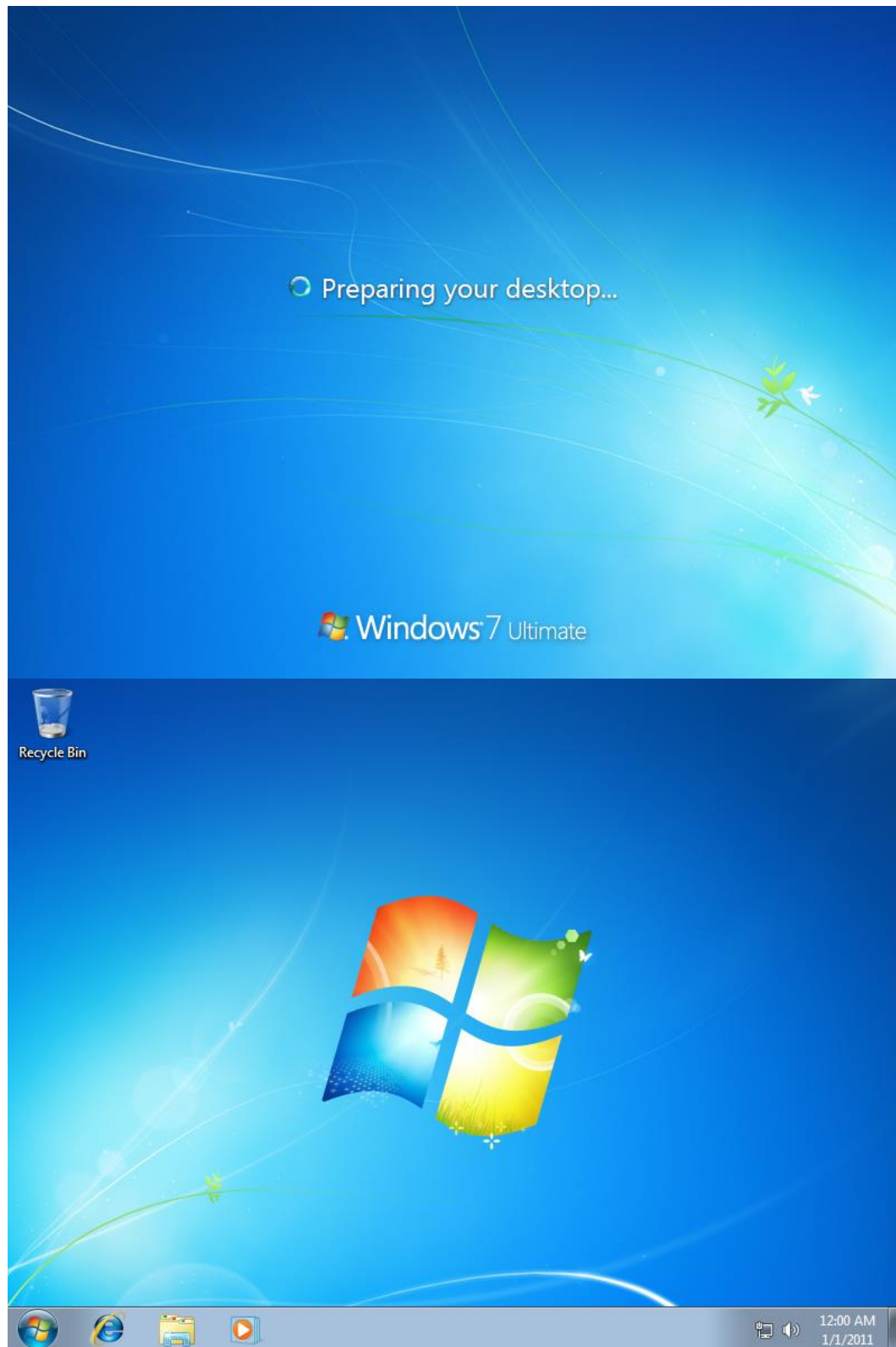

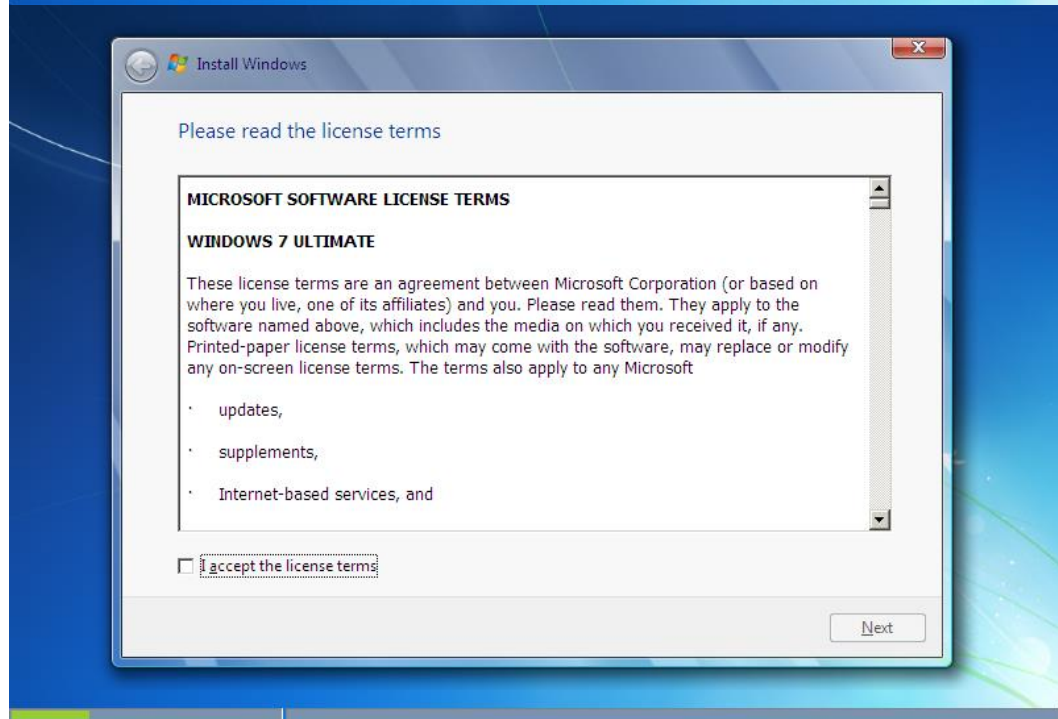

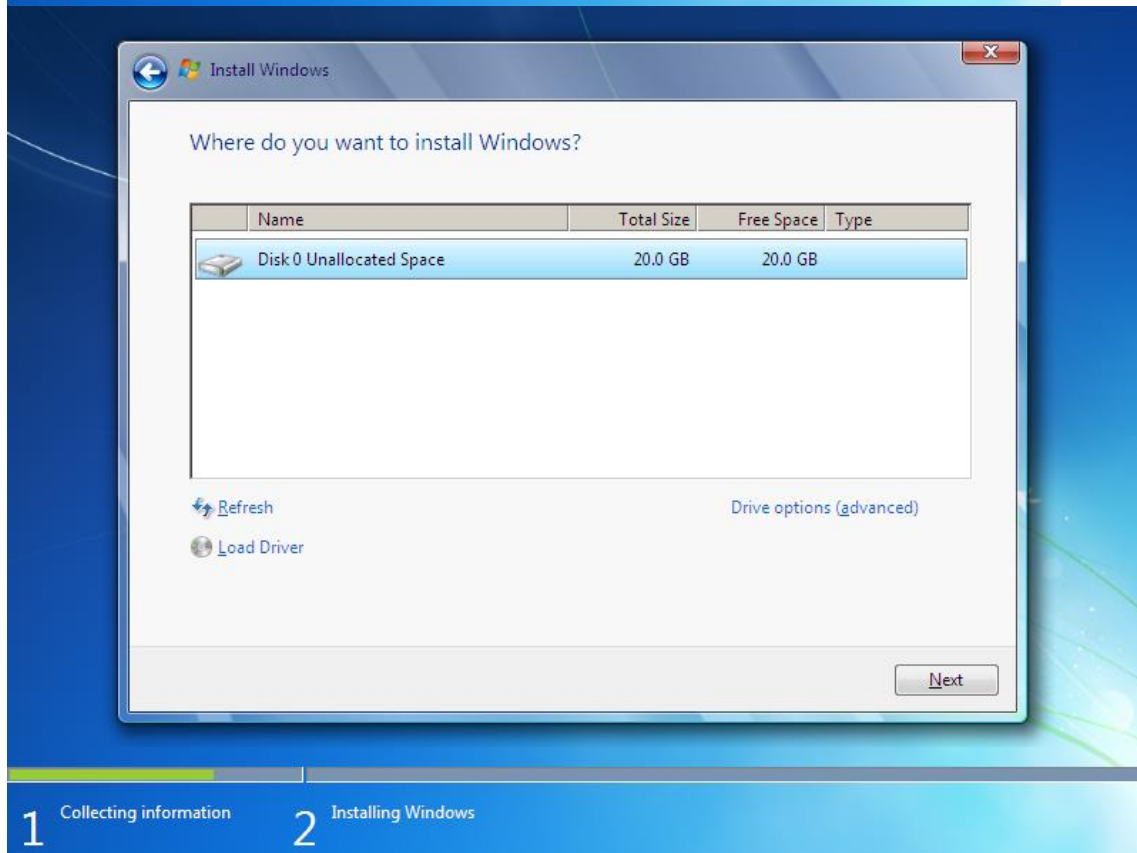
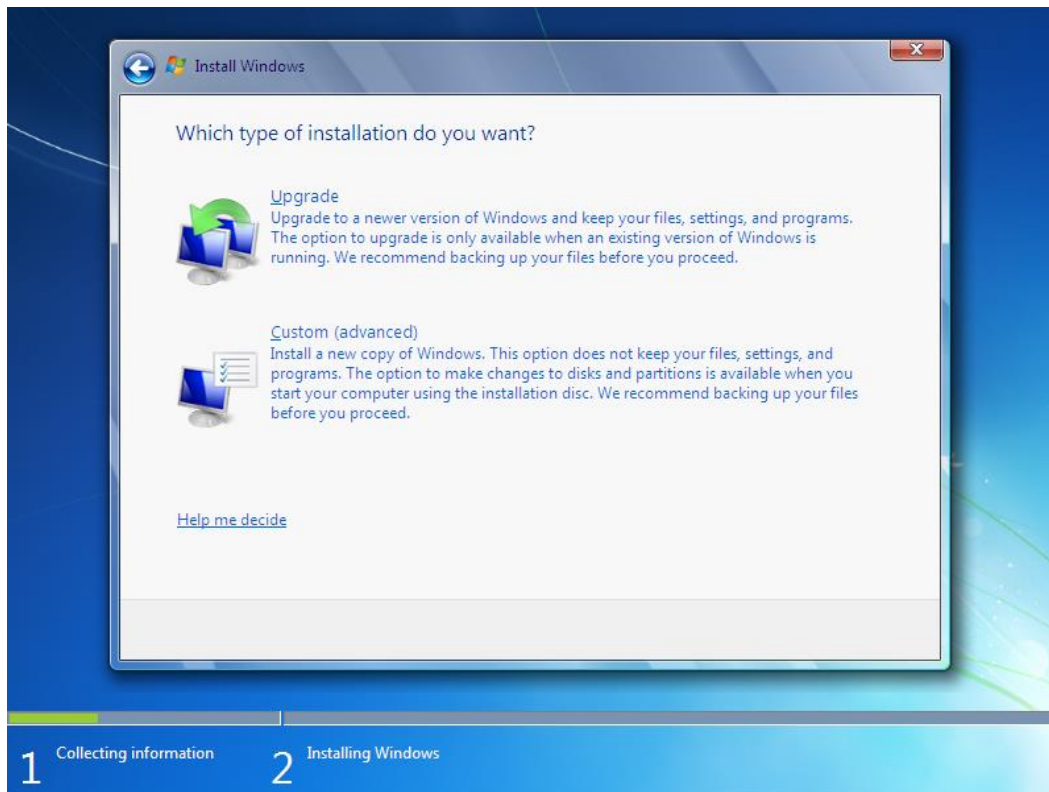

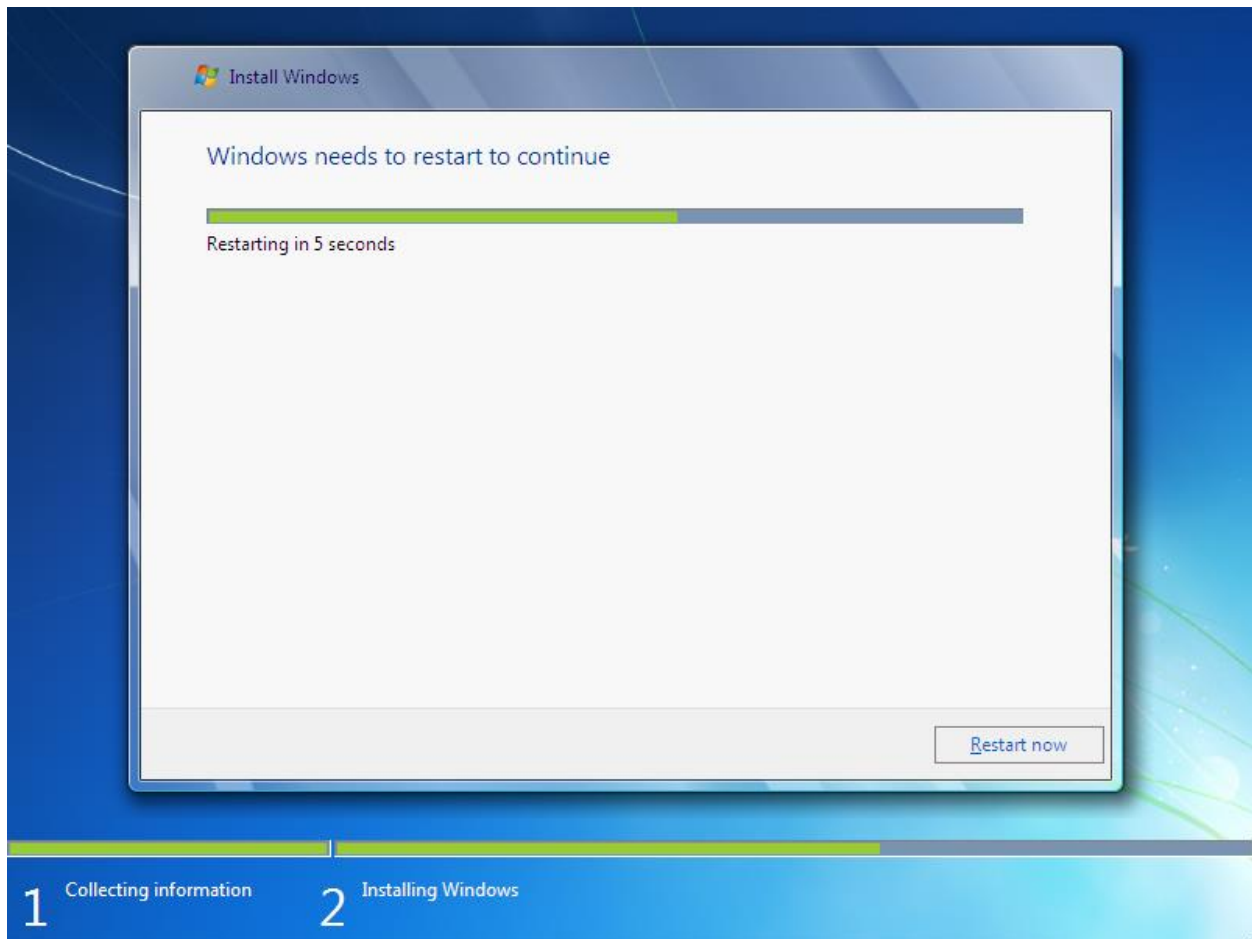

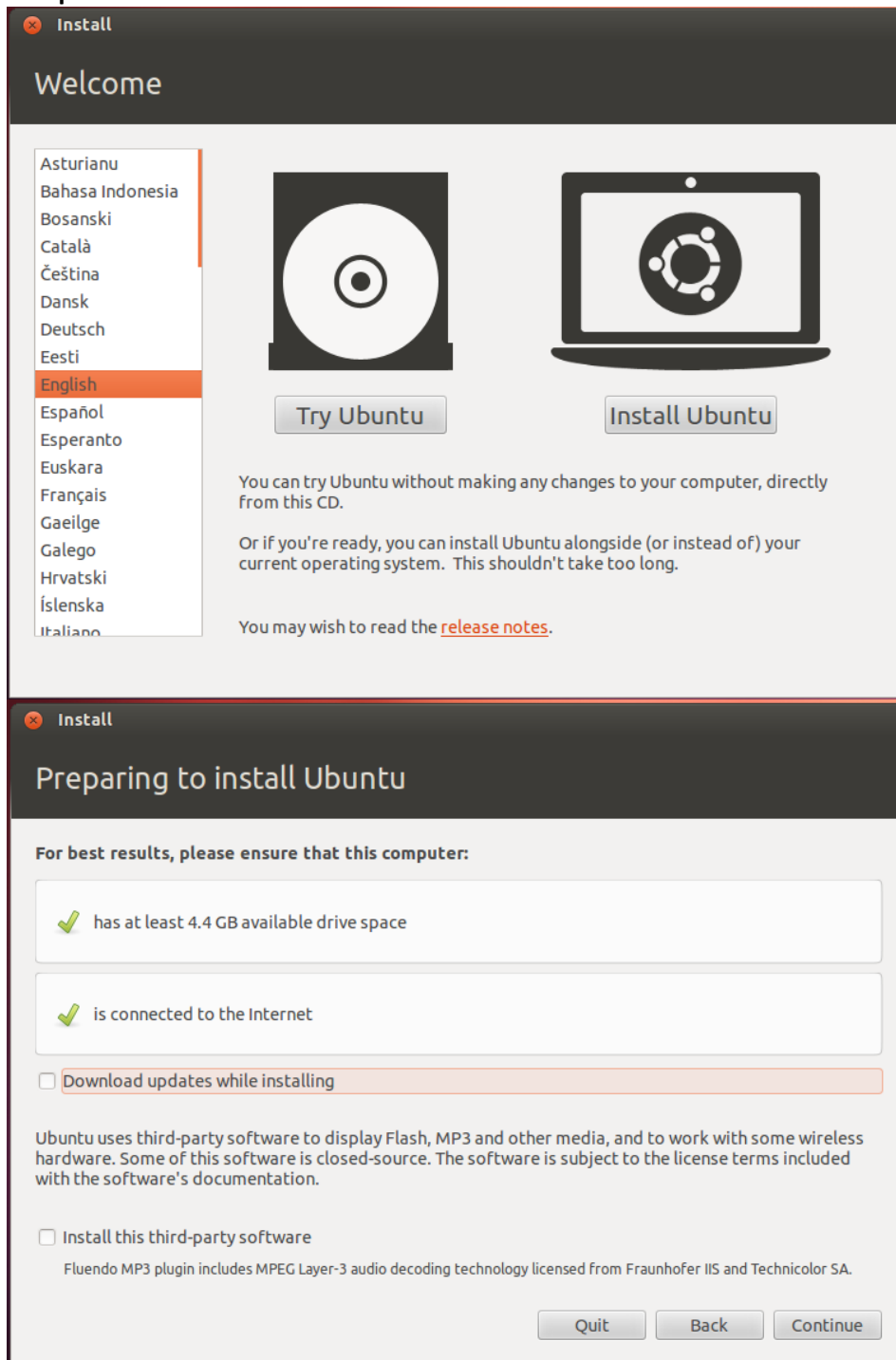

Setup and Installation Ubuntu 12.04



Install

Installation type

This computer currently has no detected operating systems. What would you like to do?

-  **Erase disk and install Ubuntu**
Warning: This will delete any files on the disk.
-  **Something else**
You can create or resize partitions yourself, or choose multiple partitions for Ubuntu.

Install

Erase disk and install Ubuntu

Select drive:

The entire disk will be used:



Ubuntu
/dev/sda (ext4)
8.6 GB

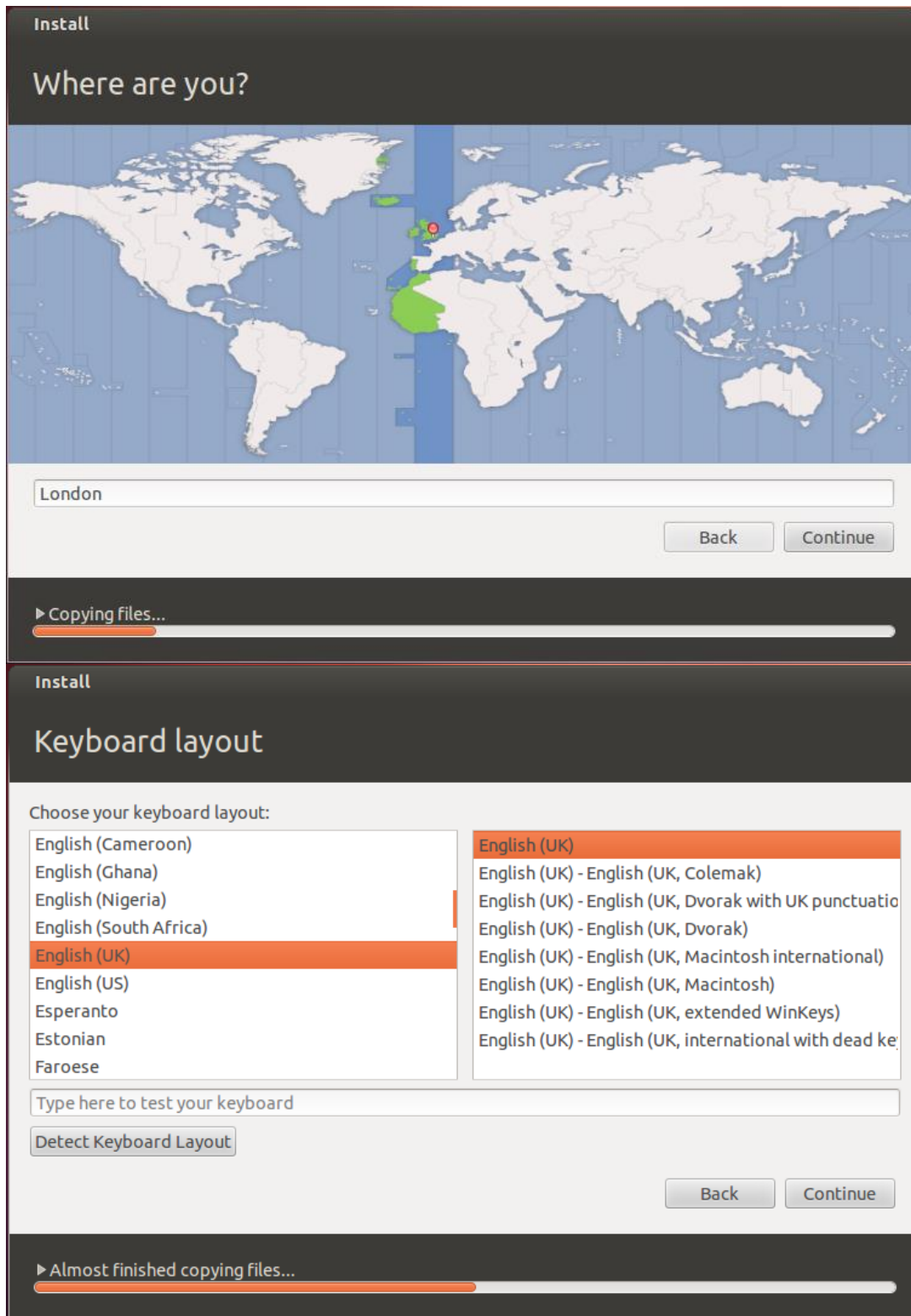

Install

Who are you?

Your name: ✓

Your computer's name: ✓
The name it uses when it talks to other computers.

Pick a username: ✓

Choose a password:

Confirm your password:

Log in automatically

Require my password to log in

Encrypt my home folder

▶ Almost finished copying files...

Install

Welcome to Ubuntu 12.04 LTS

Fast and feature-packed, Ubuntu makes your PC a delight to use. And with the latest version of the Unity interface, it's now easier than ever. Here are a few more cool new things to look out for.



▶ Installing system

Install

Have fun with your photos

Shotwell is a handy photo manager that is ready for your gadgets. Connect a camera or a phone to transfer your photos, then it's easy to share them and keep them safe. If you're feeling creative, you can try lots of photo apps from the Ubuntu Software Centre.

Included software

- Shotwell Photo Manager

Supported software

- GIMP Image Editor
- PiTiVi Video Editor

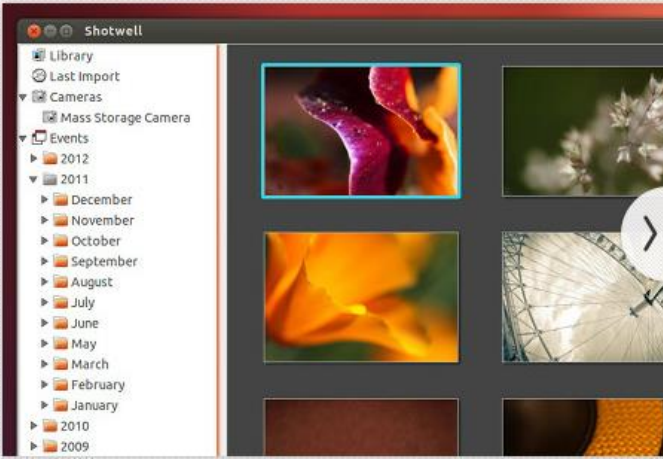

▶ Retrieving file 10 of 45 (28s remaining)

Install

Your own personal cloud

An **Ubuntu One Free** account gives you 5GB of cloud storage, so you can store and sync your files and photos across devices and access them wherever you are in the world. Easily share them with friends, family and colleagues. Take a photo on your mobile phone and immediately see it on your desktop, or add **Music Streaming** for mobile to enjoy your music on the move.



▶ Retrieving file 12 of 45 (5min 44s remaining)

Install

Take your music with you

Ubuntu comes with the amazing Rhythmbox music player. With advanced playback options and the Ubuntu One music store built in, it's simple to queue up the perfect songs. And it works great with CDs and portable music players, so you can enjoy all your music wherever you go.

Included software

- Rhythmbox Music Player
- Ubuntu One Music Store

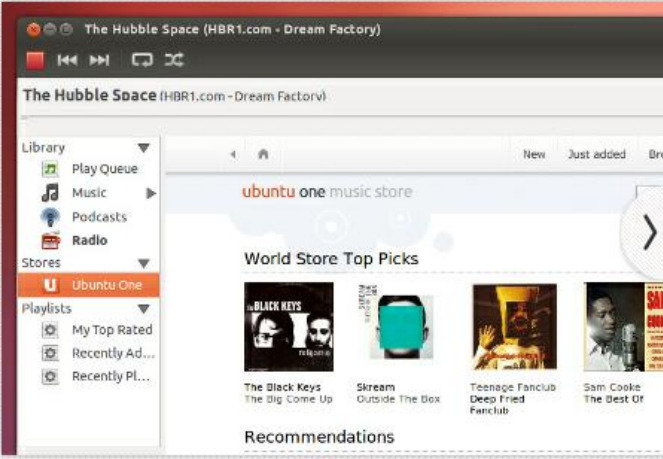

The screenshot shows the Ubuntu One music store interface. On the left is a sidebar with a 'Library' menu containing 'Play Queue', 'Music', 'Podcasts', and 'Radio'. Below that are 'Stores' with 'Ubuntu One' selected, and 'Playlists' with 'My Top Rated', 'Recently Ad...', and 'Recently PL...'. The main content area displays the 'ubuntu one music store' header, followed by 'World Store Top Picks' featuring album covers for 'The Black Keys', 'Scream', 'Teenage Fanclub', and 'Sam Cooke'. A 'Recommendations' section is visible at the bottom.

▶ Retrieving file 12 of 45 (3min 32s remaining)

Install

Stay connected

The Ubuntu Message Indicator gives you an eagle-eye view of incoming messages from all applications and social networks. See at a glance when there's something new to read, regardless how it arrived.

Supported services

- Twitter
- Facebook
- Identi.ca

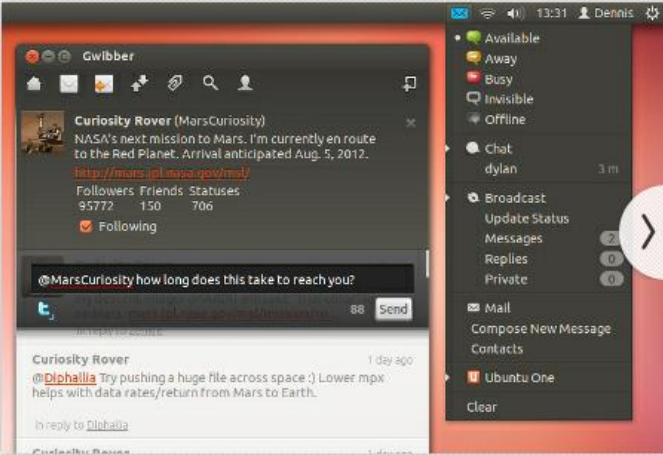

The screenshot shows the Ubuntu Message Indicator. On the left, a 'Gwibber' window displays a tweet from 'Curiosity Rover (MarsCuriosity)' about NASA's mission to Mars. The tweet text includes: 'NASA's next mission to Mars. I'm currently en route to the Red Planet. Arrival anticipated Aug. 5, 2012. http://mars.jpl.nasa.gov/mal/ Followers: 95772 Friends: 150 Statuses: 706 [x] Following'. Below the tweet is a reply from '@Diphallia' asking 'how long does this take to reach you?'. On the right, the system status menu is open, showing options like 'Available', 'Away', 'Busy', 'Invisible', 'Offline', 'Chat', 'Broadcast', 'Update Status', 'Messages', 'Replies', 'Private', 'Mail', 'Compose New Message', 'Contacts', 'Ubuntu One', and 'Clear'. The system tray at the top right shows the time as 13:31 and the user as Dennis.

▶ Retrieving file 12 of 45 (9min 11s remaining)

Install

Browse the web

Ubuntu includes Mozilla Firefox for fast and safe web browsing. It's easy to use and it's backed by a non-profit foundation that loves the web. If you aren't a Firefox fan, there are also lots of alternatives in the Ubuntu Software Centre.

Included software

- Firefox web browser

Supported software

- Flash
- Chromium



► Retrieving file 12 of 45 (3min 16s remaining)

Install

Write and present for free

LibreOffice is a free office suite packed with everything you'll need to create impressive documents, spreadsheets, and presentations. LibreOffice tries its best to work with other office software, and it uses the OpenDocument standards for far-reaching compatibility.

Included software

- LibreOffice Writer
- LibreOffice Calc
- LibreOffice Impress

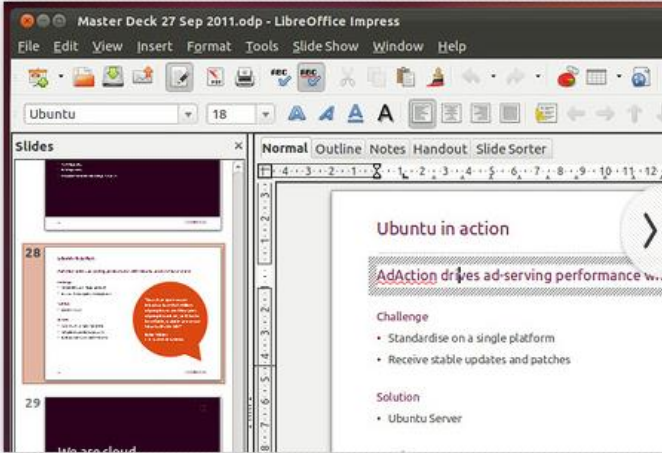

► Retrieving file 12 of 45 (3min 33s remaining)

Install

Customise Ubuntu

At the heart of Ubuntu's philosophy is a belief that computing is for everyone. With advanced accessibility tools and options like your preferred colour scheme, text size, and language; whoever you are, wherever you are, Ubuntu is for anyone.

Customisation options

- Appearance
- Assistive technologies
- Language support



▶ Retrieving file 12 of 45 (2min 49s remaining)

Install

Any questions?

Check out [Ask Ubuntu](#), the best place to get an answer about Ubuntu. With most questions already answered, and thousands of people ready to help, you'll be sorted in no time at all. And if you need an answer on a deadline, you can get commercial support and more at ubuntu.com/support.

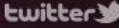
Let's talk Ubuntu 

Ubuntu Cloud [ubuntucloud](#)
RT @undacuvabrutha Wanna testdrive @OpenStack Essex with @ubuntu Server 12.04LTS? Download @ubuntucloud live -> tinyurl.com/7rh7o7d



▶ Retrieving file 12 of 45 (1min 48s remaining)

Installation Complete

 Installation is complete. You need to restart the computer in order to use the new installation.

[Restart Now](#)

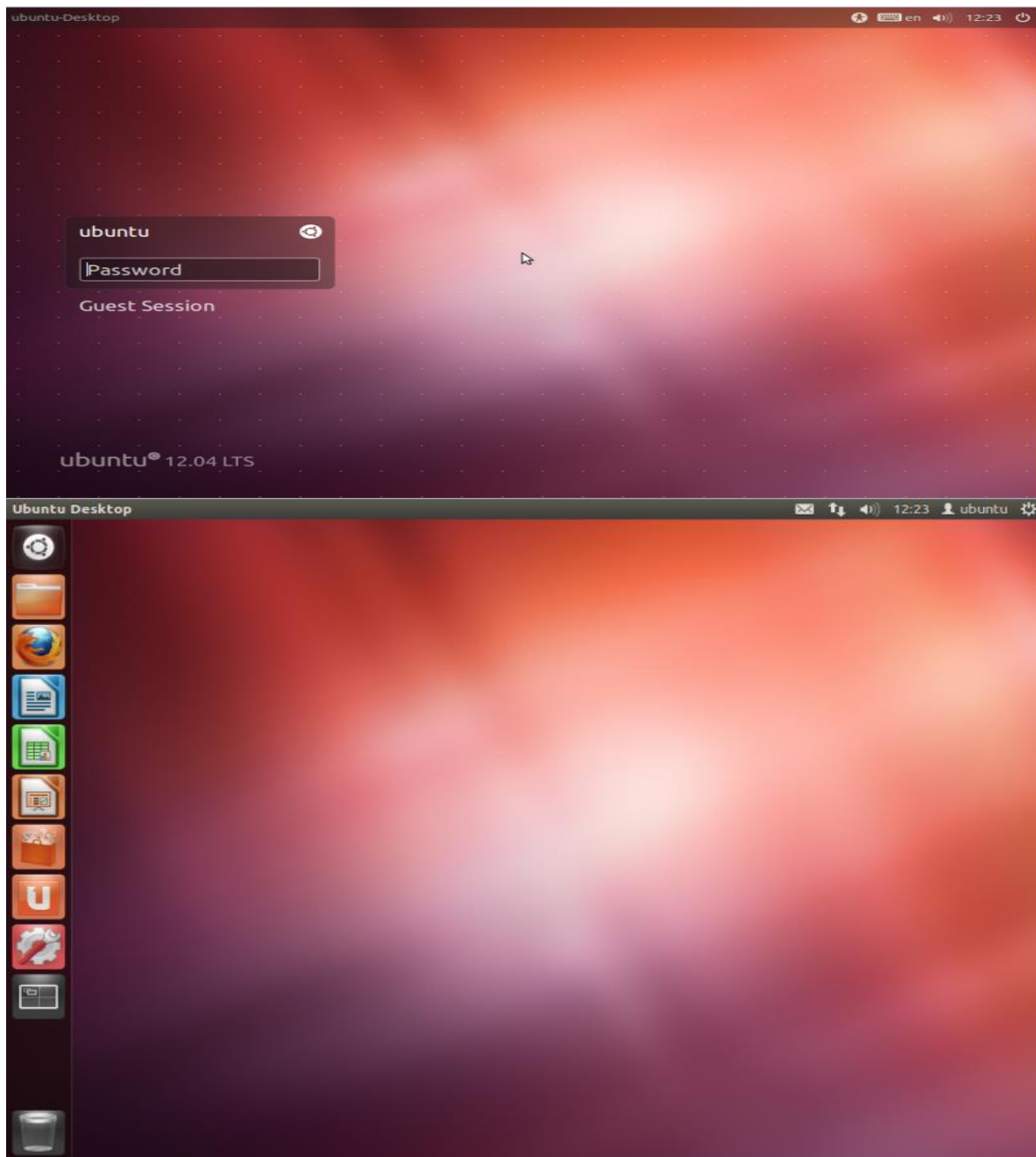
**Dual Boot Windows XP and Ubuntu.**

Step 1. Install Windows XP or Windows 7 with one Empty Partition or un Partition Space more than or equal to 5GB.

Step2. Boot from Ubuntu CD/DVD and follow the steps as above except the given below.

Step3. Select something else.

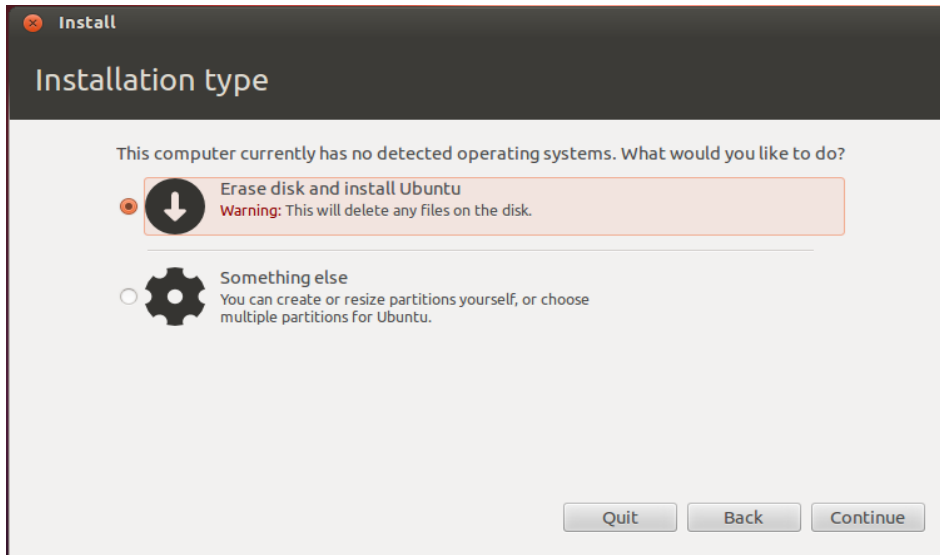

Step 4. Select the Empty partition or delete extra partition except NTFS and prepare partition.

